

**freud.**

---

**Circular Saw Blades**  
**Lame Circolari**

Catalogue 2014/15 - Catalogo 2014/15

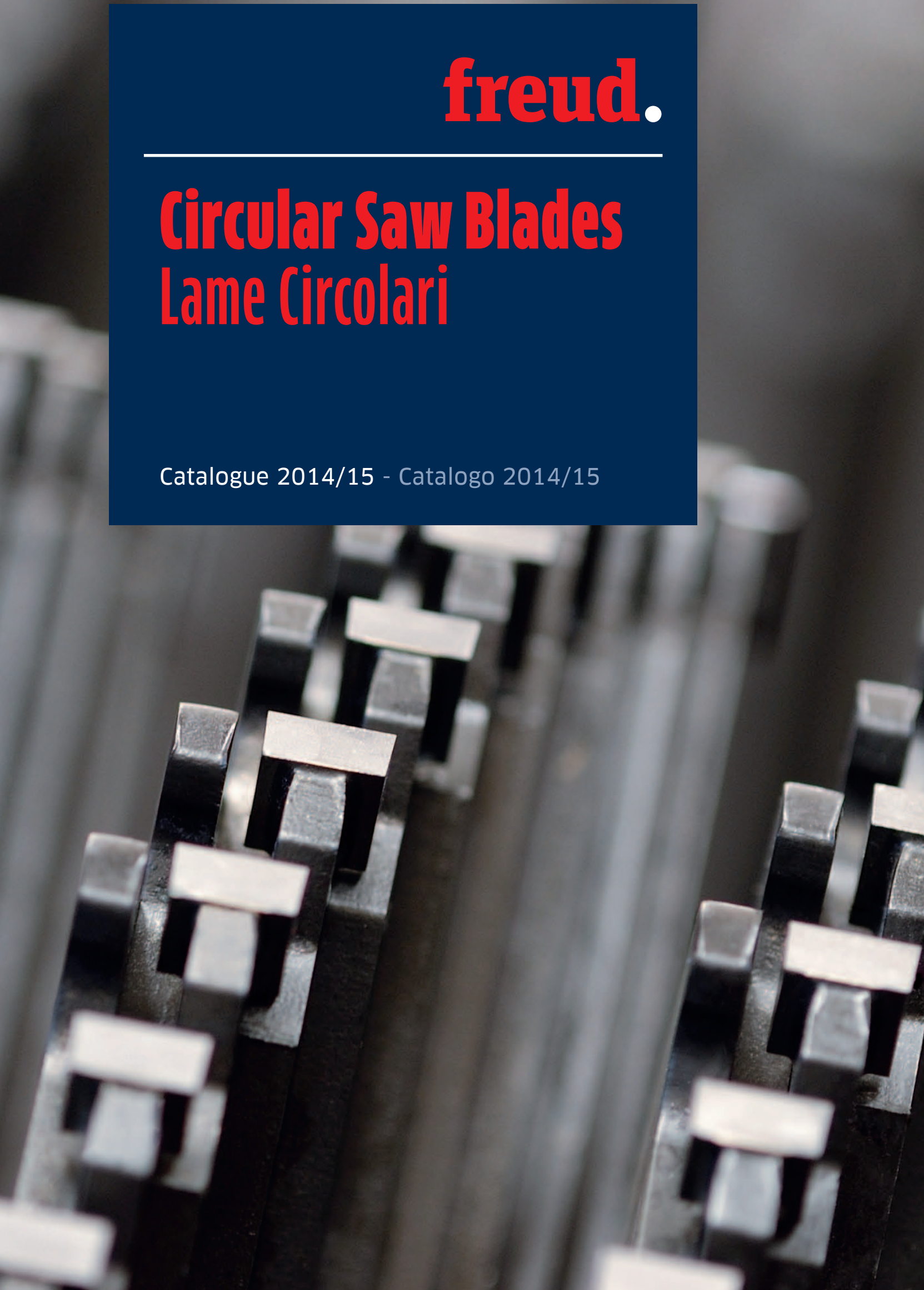

# Index Indice

## Industrial quality saw blades - Choose the right tool

Lame di qualità industriale - Guida alla scelta dell'utensile	
For industrial machines - Per macchine industriali	Pag. 10
For portable machines - Per macchine portatili	Pag. 11

## Teeth shape varieties as applied to sawblades

Tipologie di dentature applicate alle lame	Pag. 12 - 13
--	--------------

## Thin kerf multiripping saw blades

Multilame a spessore sottile	
LM01	Pag. 14

## Reduced kerf multiripping saw blades

Multilame a spessore ridotto	
LM02	Pag. 15
LM03	Pag. 16

## Multiripping saw blades - Standard kerf

Multilame a spessore normale	
LM04	Pag. 17
LM05	Pag. 18

## Increased kerf multiripping saw blades

Multilame a spessore maggiorato	
LM06	Pag. 19

## Thick kerf multiripping saw blades

Multilame a grosso spessore	
LM07	Pag. 20

## Ultra-thin kerf multiripping saw blades

Multilame a spessore ultrasottile	
LM08	Pag. 21

## Universal saw blades for cutting solid wood

Lame universali per il taglio di legno massiccio	
LU1A	Pag. 22
LU1B	Pag. 23
LU1C	Pag. 24
LU1D	Pag. 25
LU1E	Pag. 26
LU1F	Pag. 27
LU1G	Pag. 28
LU1H	Pag. 29
LU1I	Pag. 30
LU1L	Pag. 31
LG1C	Pag. 44

## Universal saw blades for cutting wood and composite materials

Lame universali per il taglio di pannelli di legno e composti	
LU2A	Pag. 32
LU2B	Pag. 33
LU2C	Pag. 34
LU2D	Pag. 35
LU2E	Pag. 36
LU2F	Pag. 37
LG2A	Pag. 45
LG2B	Pag. 46
LG2C	Pag. 47

## Universal saw blades for cutting bilaminated panels

Lame universali per il taglio di pannelli bilaminati	
LU3A	Pag. 38
LU3B	Pag. 39
LU3C	Pag. 40
LU3D	Pag. 41
LU3E	Pag. 42
LU3F	Pag. 43
LG3D	Pag. 48

## Reference table of saw blades for panel sizing machines

Tavola di riferimento delle lame per macchine sezionatrici	Pag. 49 - 53
--	--------------

## Panel sizing saw blades

Lame per la sezionatura di pannelli	
LSA	Pag. 54
LSB	Pag. 55 - 57
LSC	Pag. 58

## Conical scoring saw blades

Lame incisore coniche	
LI25M	Pag. 59 - 60

## Adjustable scoring saw blades

Lame incisore regolabili	
LI16M	Pag. 61

## Postforming scoring saw blades

Lame incisore postforming	
LI27M	Pag. 62

## Flat tooth scoring saw blades

Lame incisore con dente piano	
LI20M	Pag. 62
LI17M	Pag. 63

## Bevelled tooth scoring saw blades

Lame incisore con dente inclinato	
LI22MD - LI22MS	Pag. 63
LI13MD - LI13MS	Pag. 64

## End trim unit for panels with bended edges

Lame incisore-intestatore per pannelli bordati	
LI14MD - LI14MS	Pag. 64

## Saw blades for freud hogging units

Lame per truciolatori freud	
LT16MD - LT16MS	Pag. 65
LT18MD - LT18MS	Pag. 66

## Saw blades for hogging units

Lame per truciolatori	
LT12MD - LT12MS	Pag. 65
LT14MD - LT14MS	Pag. 66

## Saw blades for Leuco hogging units

Lame per truciolatori Leuco	
LT20MD - LT20MS	Pag. 67

## Hogging units with HW turnover knives

Truciolatori con coltelli a gettare in HW	
TR15MD - TR15MS	Pag. 68

## Hogging units with SR06M interchangeable inserts

Truciolatori con inserti intercambiabili SR06M	
TR16MD - TR16MS	Pag. 69

## Mounting sleeves for hogging units

Mozzi per truciolatori	
MT01M	Pag. 68 - 69

## Universal saw blades to cut plastic materials

Lame universali per il taglio di plastica e derivati	
LU4A	Pag. 70
LU4B	Pag. 71

## Saw blades to cut solid surfaces

Lame per il taglio di materiali polimerici	
LU4D	Pag. 72

## Saw blades to cut non-ferrous metals

Lame per il taglio di metalli non ferrosi	
LU5A	Pag. 73
LU5B	Pag. 74
LU5C	Pag. 75
LU5D	Pag. 76
LU5E	Pag. 77

## Universal saw blades to cut mild steel

Lame per il taglio di metalli ferrosi e acciaio dolce	
LU6A	Pag. 78

## SAW BLADES FOR PORTABLE MACHINES

### LAME CIRCOLARI PER MACCHINE PORTATILI

#### Saw blades for cutting solid wood

Lame per il taglio di legno massiccio	
LP20M	Pag. 79
LP30M	Pag. 80
LP40M	Pag. 81

#### Saw blades for hardwood and softwood

Lame circolari per legno tenero e duro	
LP60M	Pag. 82

#### HW- Saw blades for on-site jobs

Lame per l'edilizia	
LP70M	Pag. 83

#### Saw blades to cut non-ferrous metals

Lame per il taglio di metalli non ferrosi	
LP40M	Pag. 81
LP80M	Pag. 84

#### Saw blades to cut ferrous metals

Lame per il taglio di metalli ferrosi	
LP90M	Pag. 84

#### Saw blades to cut aluminum and bilaminated panels

Lame per il taglio di alluminio e pannelli bilaminati	
LP85M	Pag. 85

#### Saw blades to cut multi-material

Lame per il taglio di materiali diversi	
LP91M	Pag. 85

#### Standard reduction rings for saw blades

Bussole di riduzione rettificate per lame circolari	
BL15M - BL20M	Pag. 86

#### Optional workings - Standard keyways

Lavorazioni opzionali - Chiavette standard	
OPT06	Pag. 86

#### Optional workings - Special keyways

Lavorazioni opzionali - Chiavette speciali	
OPT07	Pag. 86

#### Optional workings - Special reboring

Lavorazioni opzionali - Allargatura fori	
OPT08	Pag. 86

#### Optional workings - Safety pin holes for saw blades

Lavorazioni opzionali - Fori di trascinamento	
OPTFO	Pag. 87

#### Tips for the correct use of a saw blade

Consigli per l'uso corretto di una lama	Pag. 89 - 95
---	--------------

#### Explanation of symbols and abbreviations

Legenda dei simboli e delle abbreviazioni	Pag. 96
---	---------

**freud.**

---

# **Circular Saw Blades Lame Circolari**

Catalogue 2014/15 - Catalogo 2014/15

# Innovation leader Leader dell'innovazione

The biggest manufacturer of high quality  
saw blades in the world.

Il più grande produttore al mondo di lame  
circolari di alta qualità.



**Innovative solutions due to:**

- Manufacturing know-how.
- Advanced research and engineering capability: freud is investing in innovative ways to develop new products specially designed to serve the customer needs.

**Soluzioni innovative grazie a:**

- Know-how produttivo.
- Risorse avanzate per la ricerca ed i servizi di ingegneria: freud sta investendo in strumenti all'avanguardia per lo sviluppo di nuovi prodotti appositamente progettati per rispondere alle esigenze dei clienti.

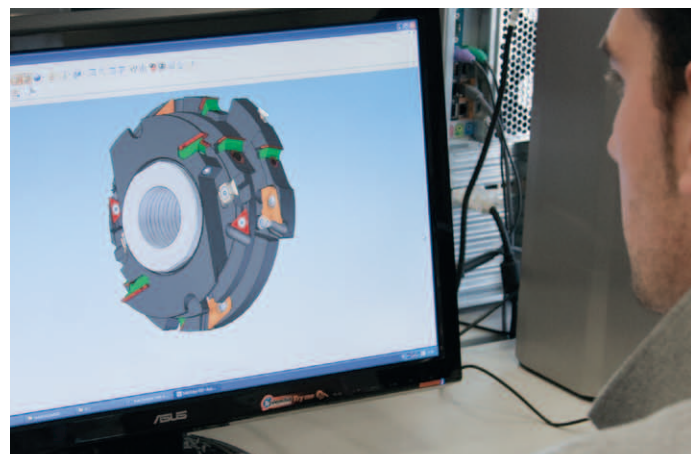

Advanced research and engineering department. Centro avanzato di ricerca e ingegneria.

**In-house Tungsten Carbide (HW) production for the ability to:**

- Mix special HW grades according to the application needs.
- Develop special tooth geometries for perfect cuts.
- Perfectly control the quality of the carbide grades.

**Produzione in proprio di Carburo di Tungsteno (HW) con la possibilità di:**

- Miscelare specifici gradi di HW in base alle esigenze applicative.
- Sviluppare speciali geometrie dei denti per un taglio perfetto.
- Verificare con assoluta precisione la qualità dei singoli composti.

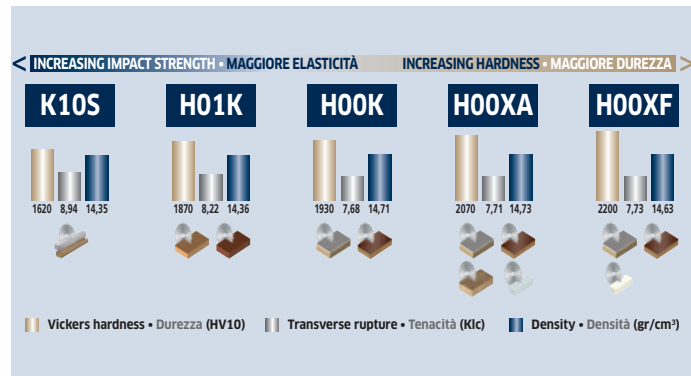

Overview of different standard HW grades. Panoramica dei diversi standard di HW.

**Excellent customized solution and service due to:**

- Customized-to-Order (CTO) products.
- Open, friendly, approachable people in over 80 countries across the world supporting you with their knowledge.

**Ottimi servizi e soluzioni personalizzate grazie a:**

- Prodotti Customized-to-Order (CTO), personalizzati in base alle specifiche del cliente.
- Il team freud, aperto, amichevole e disponibile, è presente in oltre 80 paesi ed è sempre pronto a darvi un supporto esperto.



Present all over the world. Presenti nel mondo.

# Increase your productivity Aumentate la vostra produttività

Better value for money.  
Maggiore convenienza.

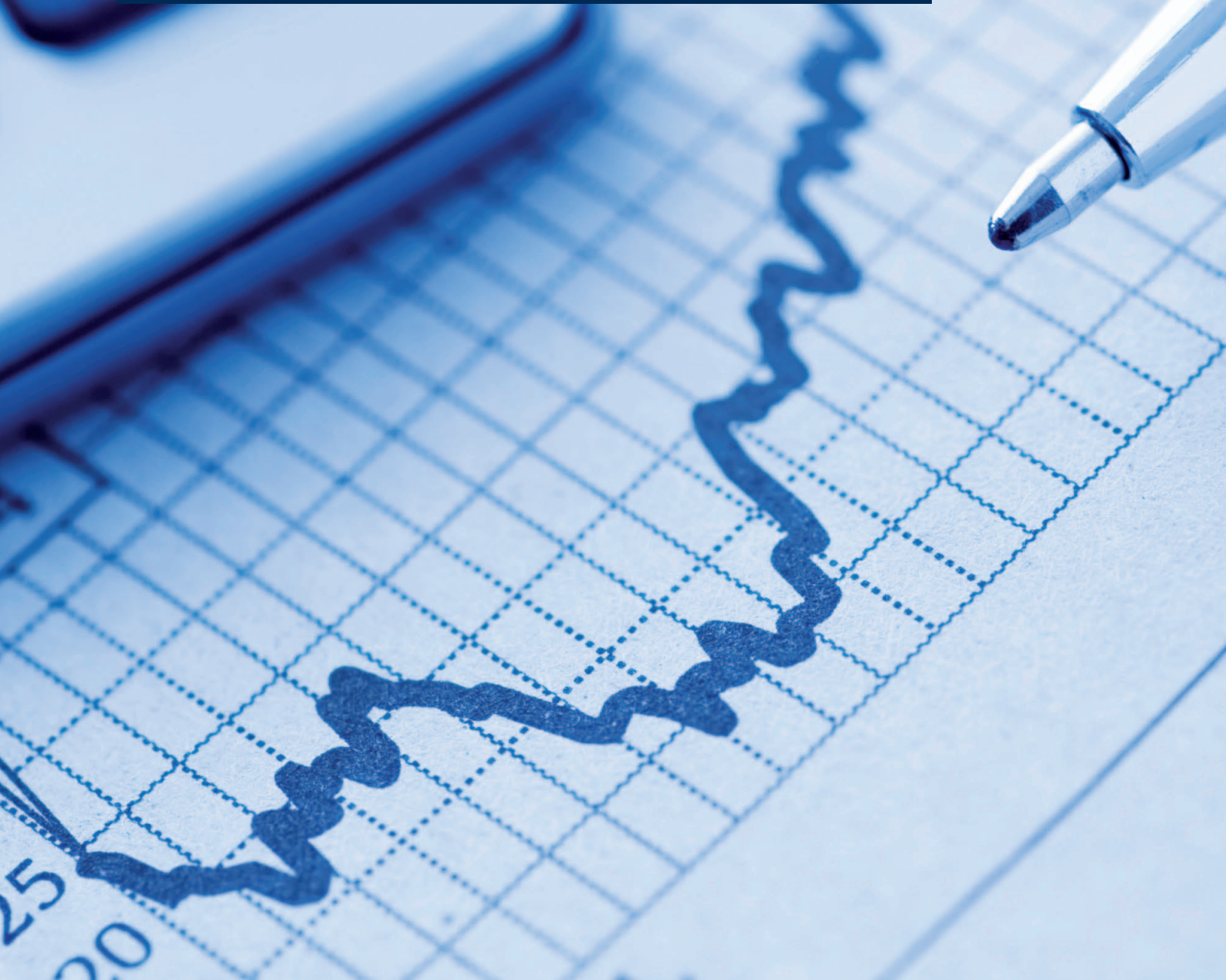

**High resistance to heat and wear: TiCo Hi-Density Carbide.**

- TiCo™ Hi-Density Carbide is a specially formulated, highly compact Titanium Cobalt Carbide engineered and manufactured by freud.
- It maximizes performance on all freud cutting tools.

**Alta resistenza al calore e all'usura: Metallo Duro Ti-Co ad alta densità.**

- Il TiCo™, Metallo Duro ad alta densità, è uno speciale composto di Titanio e Cobalto, estremamente compatto.
- È progettato e prodotto da freud per massimizzare le prestazioni di tutti gli utensili da taglio.

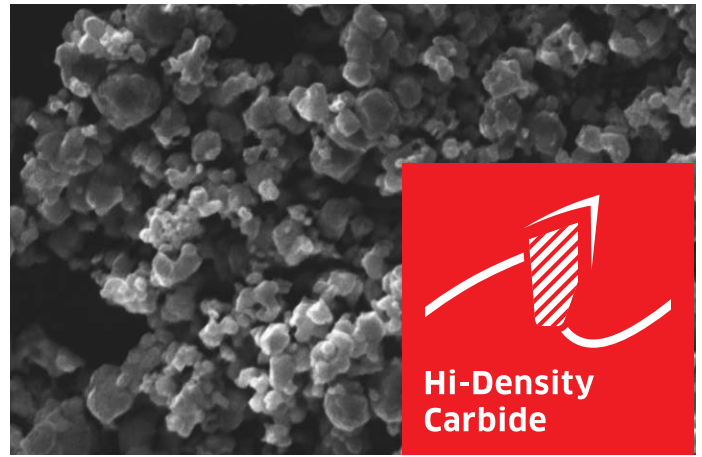

TiCo™ Hi-Density carbide.  
Metallo Duro TiCo™ ad alta densità.

**Up to 8 times re-sharpenable: supersquare tooth design.**

- Tip thickness is 30% greater than standard tips to allow up to 8 re-sharpenings.
- The tips lateral cutting edge is smaller therefore the tips have a lower propensity to follow the wood grain. The cut is more precise.

**Fino ad 8 affilature: geometria del dente superquadro.**

- Lo spessore del dente è del 30% superiore rispetto allo standard per consentire fino a 8 affilature.
- Il lato tagliente è ridotto per eliminare la tendenza del dente a seguire le venature del legno e garantire così un taglio più preciso.

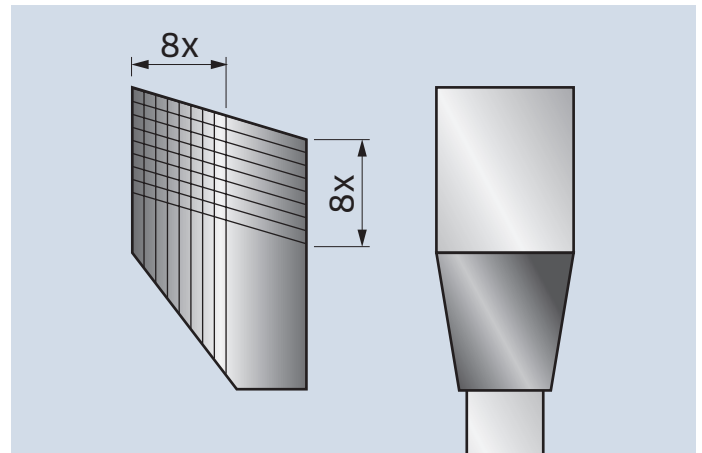

Supersquare tooth.  
Dente superquadro.

**Maximum durability: trimetal shock resistant brazing.**

- freud special tri-metal alloy consists of copper wrapped between layers of silver.
- It allows carbide tips to withstand extreme impact for maximum durability.

**Massima durata: brasatura trimetallica resistente agli urti.**

- La speciale lega trimetallica freud consiste in uno strato di rame avvolto da due esterni in argento.
- Permette ai taglienti di resistere ai notevoli impatti che la lama subisce in fase di lavoro, prolungandone al massimo la durata.

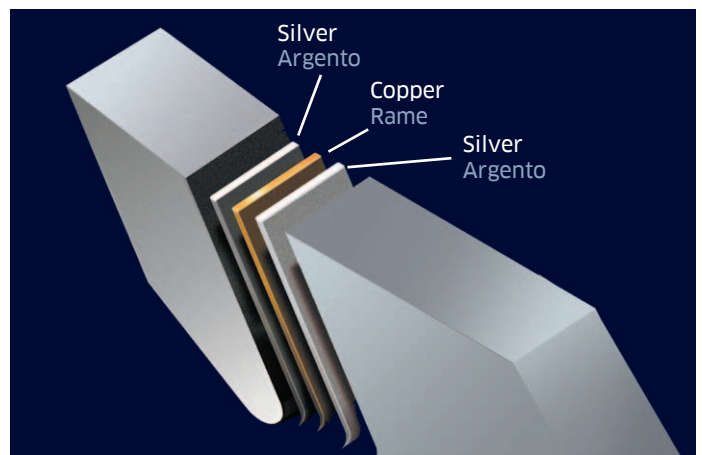

Tri-metal brazing.  
Brasatura trimetallica.

# Superior finishing Finitura superiore

No additional re-work from the first  
to the last cut.

Nessuna ulteriore lavorazione  
dal primo all'ultimo taglio.



### 60% less friction: Silver I.C.E. Coating.

- A high-performance and anticorrosive coating, laid over the whole blade body, approximately 6-microns thick.
- The non-stick feature improves chip ejection and notably reduces resin build-up.
- It protects the tool for its entire cutting life and leads to reduced friction up to 60%, for a more precise cut.

### 60% di attrito in meno: rivestimento Silver I.C.E.

- Un rivestimento altamente performante e anticorrosivo, applicato integralmente sul corpo lama, spesso circa 6-micron.
- Le sue qualità di antiaderenza favoriscono lo scarico del truciolo e riducono notevolmente l'accumulo di resina.
- Protegge l'utensile per tutta la sua durata e riduce l'attrito fino al 60%, aumentando notevolmente la qualità di taglio.



Silver I.C.E. logo.  
Logo Silver I.C.E.

### Less vibration: antivibration slots with thermal-plastic polyurethane filling.

- The material is injected in the slots specially cut in the blade with an innovative laser technology.
- The elasticity and the noise absorbing features considerably reduce vibration.

### Meno vibrazioni: intagli antivibrazione con iniezione di poliuretano termoplastico.

- Il materiale è iniettato all'interno degli appositi intagli realizzati sul corpo della lama tramite un'innovativa tecnologia laser.
- La sua elasticità e la proprietà fonoassorbente riducono notevolmente le vibrazioni dell'utensile in fase di lavoro.

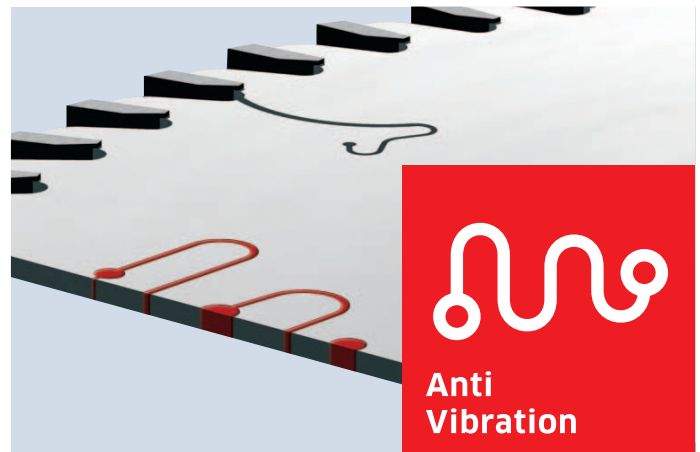

Section view of antivibration slots.  
Vista in sezione degli intagli antivibrazione.

### No distortion in the blade: laser cut steel, tensioning and balancing.

- The high strength laser cut steel extends blade durability and the tensioning process guarantees maximum precision.
- An automated system balances freud blades one by one, to completely eliminate harmful vibrations.

### Nessuna distorsione nella lama: acciaio tagliato al laser, tensionatura ed equilibratura.

- L'acciaio temprato ad alta durezza, tagliato al laser, aumenta la durata della lama mentre la tensionatura garantisce la massima precisione.
- Le lame freud vengono equilibrate singolarmente con attrezzature di precisione automatizzate, che eliminano totalmente la possibilità di dannose vibrazioni.

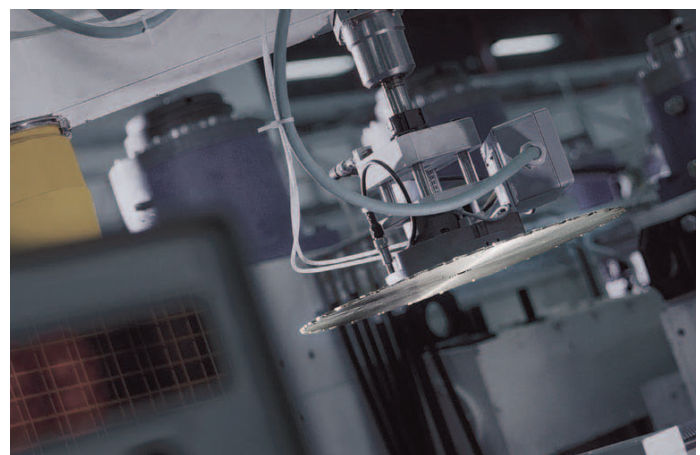

Balancing.  
Equilibratura.

# Always available for your needs Sempre a disposizione per le vostre esigenze

Customized solutions and services  
wherever you are.

Soluzioni personalizzate ovunque  
vi troviate.



**Consultancy to research your specific needs: application engineering.**

- Our dedicated trained engineers will come to your plant in order to develop together a solution according specifically to your production process and needs.

**Consulenza per l'analisi delle vostre richieste specifiche: application engineering.**

- I nostri tecnici qualificati visiteranno la vostra sede per sviluppare insieme una soluzione specifica basata sulle esigenze del processo produttivo.



Consultancy for your specific needs.  
Consulenza per l'analisi delle vostre richieste specifiche.

**Exactly the product for your needs: Customized-To-Order (CTO) products based on our standard catalogue items.**

- For all customers requiring dedicated diameters, number of teeth, bore sizes etc. not offered in the standard catalogue, a CTO item can be produced according to the requirements.

**Customized-to-Order (CTO), il prodotto perfetto per le vostre esigenze: personalizzazione degli articoli standard.**

- Realizziamo prodotti personalizzati adattando le specifiche degli articoli di catalogo alle richieste dei clienti, intervenendo su diametro, spessore, geometrie, numero di denti o diametro foro etc.

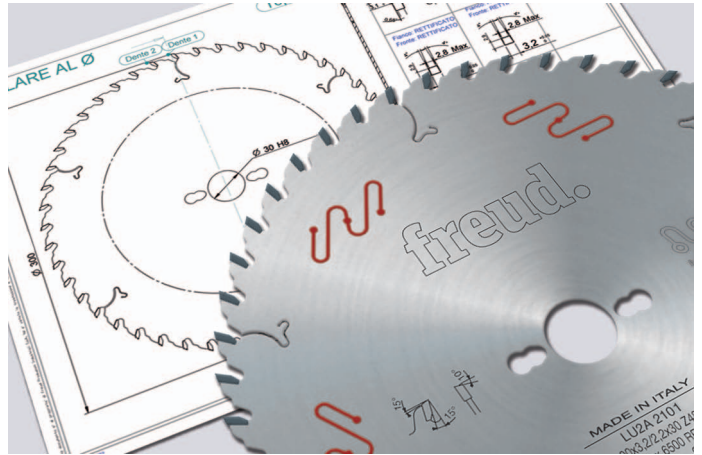

Customized-to-Order service (CTO).  
Servizio di personalizzazione lame CTO.

**Available wherever you are: our people.**

- In the mindset of “think global, act local”, our worldwide subsidiaries and partners in over 80 countries will ensure an extensive service and distribution net.

**A disposizione ovunque voi siate: il nostro personale.**

- Seguendo la logica “pensa globalmente, agisci localmente”, le nostre filiali e i partner presenti in oltre 80 Paesi assicurano un servizio capillare e una vasta rete di distribuzione.



Present all over the world.  
Presenti nel mondo.

# HW - Industrial quality saw blades - Choose the right tool

## HW - Lame di qualità industriale - Guida alla scelta dell'utensile

		FOR INDUSTRIAL MACHINES LAME PER MACCHINE INDUSTRIALI	PERFORMANCE:		
		Suitable for / Adatto per:	Ultimate Eccellente	High Ottimo	Good Buono
Softwood Legno tenero		Multi-rip saw blades for ripping Multilame per taglio lungo vena	LM01	LM02-LM03-LM04-LM05- LM06-LM07-LM08	
		Ripping Lungo vena	LU1F-LU1G	LU1C-LU1D-LU1E-LU2A-LU2B- LG1C-LG2A-LG2B	LU1A
		Cross cutting Traverso vena	LU2A-LU2B-LU2C-LU2D	LU2E-LU2F- LG2A-LG2B-LG2C	LU1E
		Ripping and cross cutting Lungo e traverso vena		LU1H	LU1B
Hardwood Legno duro		Multi-rip saw blades for ripping Multilame per taglio lungo vena	LM01	LM02-LM03-LM04-LM05- LM06-LM07-LM08	
		Ripping Lungo vena	LU1F	LU1C-LU1D-LU1E-LU2A-LU2B- LG1C-LG2A-LG2B	LU1A
		Cross cutting Traverso vena	LU2A-LU2B-LU2C-LU2D	LU2E-LG2A-LG2B-LG2C	LU1E
		Ripping and cross cutting Lungo e traverso vena		LU1H	LU1B
Laminated Laminati		Saw blades for cutting laminates Lame per il taglio di laminati	LSA-LSB-LU3A-LU3B-LU3C- LU3D-LU3E-LU3F	LG3D	
		Scoring saw blades for laminates Lame incisore per laminati	LI13MD-LI13MS-LI14MD- LI14MS-LI16M-LI17M-LI20M- LI22MD-LI22MS-LI25M-LI27M		
Wood composites Compositi di legno			LSA-LSB-LU2C-LU2D-LU2E- LU2F-LU3A-LU3B-LU3C-LU3D- LU3F	LU2A-LU2B-LU3E- LG2A-LG2B-LG2C-LG3D	LU1E-LU1H
			LU3A-LU3B-LU3C-LU3D-LU3E- LU3F	LG3D	
Picture frames Cornici			LU1I-LU1L		
			LU5A-LU5B-LU5C-LU5D-LU5E		
Non ferrous metals Metalli non ferrosi			LU6A		
Ferrous metals Metalli ferrosi			LU4A-LU4B		
			LU4A-LU4B	LU2C-LU2D-LU2F-LG2C	
Plastic materials Materiali plastici			LU4A-LU4B		
			LU4D		

# HW - Industrial quality saw blades - Choose the right tool

## HW - Lame di qualità industriale - Guida alla scelta dell'utensile

FOR PORTABLE MACHINES PER MACCHINE PORTATILI		PERFORMANCE:		
		Ultimate Eccellente	High Ottimo	Good Buono
Suitable for / Adatto per:				
Softwood Legno tenero	 Ripping Lungo vena		LP20M	
	 Cross cutting Traverso vena	LP40M-LP60M		LP20M
	 Ripping and cross cutting Lungo e trasverso vena		LP30M	LP60M-LP70M
Hardwood Legno duro	 Ripping Lungo vena		LP20M	
	 Cross cutting Traverso vena	LP40M-LP60M		LP20M
	 Ripping and cross cutting Lungo e trasverso vena		LP30M	LP60M-LP70M
Wood composites Composti di legno	 Saw blades for cutting laminates Lame per il taglio di laminati		LP85M-LP91M	
			LP91M	LP40M
			LP91M	
Veneered materials Impiallacc. di legno			LP91M	
		LP80M	LP85M-LP91M	
Non ferrous metals Metalli non ferrosi		LP90M	LP91M	
Ferrous metals Metalli ferrosi		LP65M	LP91M	
Plexiglas & plastic materials Materiali polimerici			LP91M	
Solid surfaces Materiali polimerici			LP91M	

# Teeth shape varieties as applied to saw blades

## Tipologie di dentature applicate alle lame

### FLAT TOOTH DENTE PIANO



Suitable for / Adatto per:



Ripping of softwood  
Legno tenero lungo vena



Ripping of hardwood  
Legno duro lungo vena

### TRAPEZE SHAPED TOOTH DENTE TRAPEZIO-TRAPEZIO



Suitable for / Adatto per:



Ferrous metals  
Metalli ferrosi



Solid surfaces  
Materiali polimerici

### CONICAL TOOTH DENTE CONICO



Suitable for / Adatto per:



Scoring saw blades, on laminates  
Lame incisore, su laminati

### BEVELLED TOOTH DENTE SMUSSATO

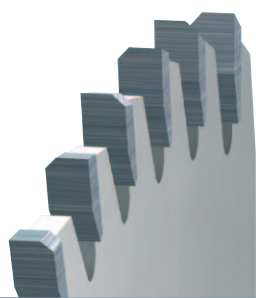

Suitable for / Adatto per:



Ripping and cross cutting of softwood  
Legno tenero lungo e trasverso vena



Ripping and cross cutting of hardwood  
Legno duro lungo e trasverso vena



Chipboard  
Truciolare



Solid wood and composites with nails and impurities  
Legni e compositi con chiodi o impurità

### TRIPLE CHIP TOOTH DENTE TRIPLE CHIP

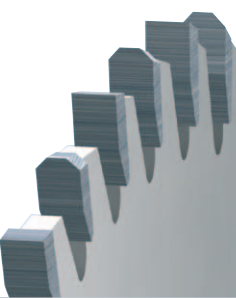

Suitable for / Adatto per:



Laminates / bilaminates  
Laminati / bilaminati



Chipboard  
Truciolare



MDF  
MDF



Plywood  
Multistrato



Plexiglas  
Plexiglas



Plastic materials  
Materiali plastici



Non-ferrous metals  
Metalli non ferrosi

### INCLINED TOOTH DENTE INCLINATO



Suitable for / Adatto per:



Cross cutting of softwood  
Legno tenero trasverso vena



Cross cutting of hardwood  
Legno duro trasverso vena



Laminates / bilaminates  
Laminati / bilaminati













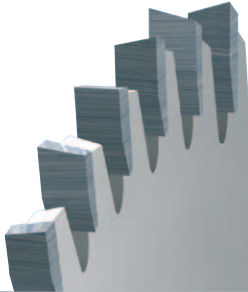

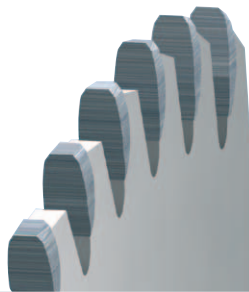



Plywood  
Multistrato











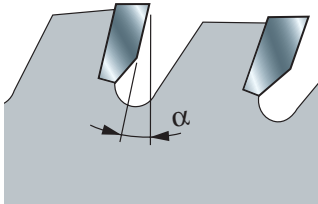
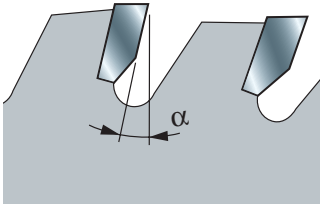
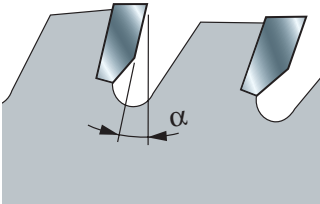
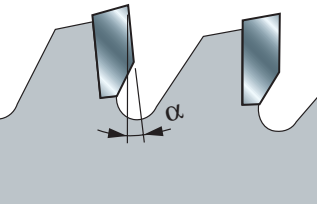





Scoring saw blades  
Lame incisore

# Teeth shape varieties as applied to saw blades

## Tipologie di dentature applicate alle lame

AXIAL TOOTH DENTE ASSIALE	CONCAVE TOOTH DENTE CONCAVO	ROUNDED TOOTH DENTE BOMBATO	ALTERNATE TOP BEVEL TOOTH DENTE ALTERNO
			
<b>Suitable for / Adatto per:</b>	<b>Suitable for / Adatto per:</b>	<b>Suitable for / Adatto per:</b>	<b>Suitable for / Adatto per:</b>
 Cross cutting of softwood Legno tenero trasverso vena	 Laminates / bilaminates Laminati / bilaminati	 Ripping of softwood Legno tenero lungo vena	 Ripping and cross cutting of softwood Legno tenero lungo e trasverso vena
 Cross cutting of hardwood Legno duro trasverso vena			 Ripping and cross cutting of hardwood Legno duro lungo e trasverso vena
 Picture frames Cornici			 Chipboard Truciolare
 Plexiglas Plexiglas			 MDF MDF
 Plastic materials Materiali plastici			 Plywood Multistrato
			 Picture frames Cornici

HOOK ANGLES ANGOLI MORDENTI			
$(\alpha) 15^\circ \div 25^\circ$	$(\alpha) 5^\circ \div 15^\circ$	$(\alpha) 0^\circ \div 5^\circ$	$(\alpha) 0^\circ \div -10^\circ$
			
<b>Suitable for / Adatto per:</b>	<b>Suitable for / Adatto per:</b>	<b>Suitable for / Adatto per:</b>	<b>Suitable for / Adatto per:</b>
 Cross cutting of softwood Legno tenero trasverso vena	 Chipboard Truciolare	 Chipboard Truciolare	 Plexiglas Plexiglas
 Cross cutting of hardwood Legno duro trasverso vena	 Plywood Multistrato	 Non-ferrous metals Metalli non ferrosi	 Plastic materials Materiali plastici
 Solid surfaces Materiali polimerici	 Laminates / bilaminates Laminati / bilaminati	 Ferrous metals Metalli ferrosi	 Non-ferrous metals Metalli non ferrosi
			 Laminates / bilaminates Laminati / bilaminati

# LM01

## HW - Thin kerf saw blades with rakers HW - Lama a spessore sottile con denti stabilizzatori

Saw blades suitable for ripping where the thin body greatly reduces material wastes. Not suitable for twisted timber.

**Machines:** Multiripping machines, moulders.

**Features:** Flat tooth.

**Material:** Soft and hard wood dried at max 10-12% humidity rate.

Lame per tagli longitudinali. Lo spessore sottile consente di ridurre gli scarti del materiale. Si raccomanda l'utilizzo esclusivamente con tavolame non distorto.

**Macchine:** Multilame mono e bialbero, scorniatrici.

**Caratteristiche:** Dentatura piana.

**Materiale:** Legni teneri e duri essiccati con umidità max del 10-12%.

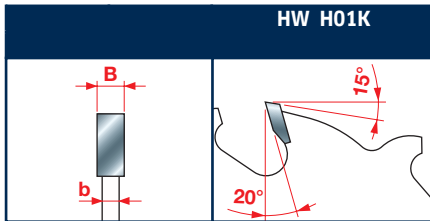
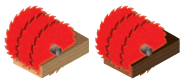
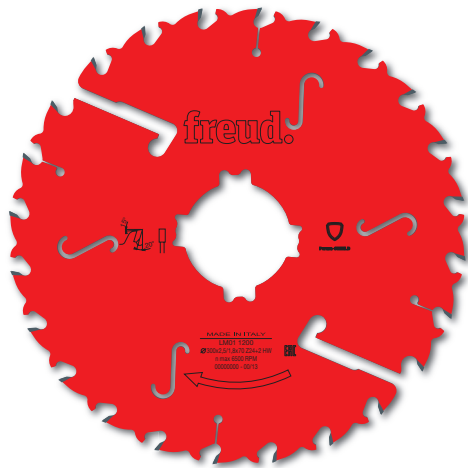

Tooth features - Caratteristiche del dente

D mm	B mm	b mm	d mm	Z	KN CH	Code Codice	SAP SAP
180	2,2	1,6	40	16+2	2CH 12x5	LM01 0100	F03FS02751
200	2,2	1,6	40	16+2	2CH 12x5	LM01 0200	F03FS02753
200	2,2	1,6	60	16+2	4CH 21x5	LM01 0300	F03FS02755
200	2,2	1,6	70	16+2	4CH 21x5	LM01 0400	F03FS02757
225	2,2	1,6	70	16+2	4CH 21x5	LM01 0500	F03FS02759
250	2,2	1,6	30	20+2	2CH 10x4	LM01 0600	F03FS02763
250	2,2	1,6	60	20+2	4CH 21x5	LM01 0700	F03FS02765
250	2,2	1,6	70	20+2	4CH 21x5	LM01 0800	F03FS02767
250	2,2	1,6	80	20+2	2CH 13x5+2CH 21x5	LM01 0900	F03FS02769
250	2,2	1,6	50	24+2	4CH 21x5	LM01 1400	F03FS02780
250	2,2	1,6	60	24+2	4CH 21x5	LM01 1500	F03FS02781
250	2,2	1,6	70	24+2	4CH 21x5	LM01 1600	F03FS02700
300	2,5	1,8	30	24+2	2CH 10x4	LM01 1000	F03FS02772
300	2,5	1,8	60	24+2	4CH 21x5	LM01 1100	F03FS02774
300	2,5	1,8	70	24+2	4CH 21x5	LM01 1200	F03FS02776
300	2,5	1,8	80	24+2	2CH 13x5+2CH 21x5	LM01 1300	F03FS02778

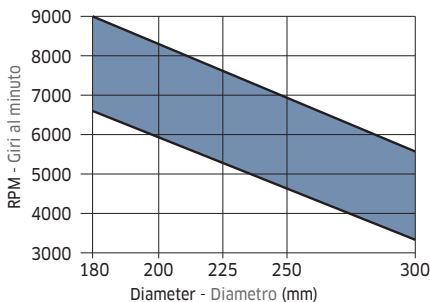

Minimum and maximum RPM based on the blade diameter.  
Fascia del N. giri minimo e massimo consigliati in funzione del diametro della lama.

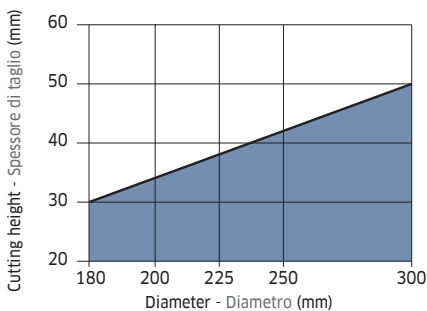

Maximum depth of cut based on the blade diameter.  
Altezza di taglio massima consentita in funzione del diametro della lama.

■ Solid wood  
■ Legno massiccio

Ultimate Eccellente	High Ottimo	Good Buono
●		
●		

Ripping of softwood  
Legno tenero lungo vena  
Ripping of hardwood  
Legno duro lungo vena

# LM02

## HW - Reduced kerf saw blades with rakers HW - Lama a spessore ridotto con denti stabilizzatori

Saw blades suitable for ripping where the thin body greatly reduces material wastes.

**Machines:** Multiripping machines, molders.

**Features:** Flat tooth.

**Material:** Soft and hard wood dried at max 15% humidity rate.

Lame per tagli longitudinali. Lo spessore sottile consente di ridurre gli scarti del materiale.

**Macchine:** Multilame mono e bialbero.

**Caratteristiche:** Dentatura piana.

**Materiale:** Legni teneri e duri essiccati con umidità max del 15%.

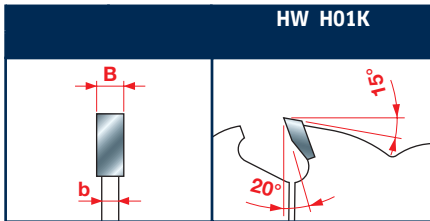
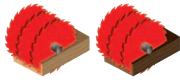

Tooth features - Caratteristiche del dente

D	B	b	d	Z	KN	Code	SAP
mm	mm	mm	mm		CH	Codice	SAP
250	2,8	2,0	30	16+2	2CH 10x4	LM02 0100	F03FS02797
250	2,8	2,0	60	16+2	4CH 21x5	LM02 0200	F03FS02799
250	2,8	2,0	70	16+2	4CH 21x5	LM02 0300	F03FS02801
250	2,8	2,0	80	16+2	2CH 13x5+2CH 21x5	LM02 0400	F03FS02803
280	2,8	2,0	80	18+2	2CH 13x5+2CH 21x5	LM02 0500	F03FS02805
300	2,8	2,0	30	20+2	2CH 10x4	LM02 0600	F03FS02807
300	2,8	2,0	60	20+2	4CH 21x5	LM02 0700	F03FS02809
300	2,8	2,0	70	20+2	4CH 21x5	LM02 0800	F03FS02811
300	2,8	2,0	80	20+2	13x5+21x5	LM02 0900	F03FS02813
320	3,0	2,2	30	20+2+2	2CH 10x4	LM02 1000	F03FS02815
320	3,0	2,2	80	20+2+2	2CH 13x5+2CH 21x5	LM02 1100	F03FS02817
350	3,0	2,2	30	24+2+2	2CH 10x4	LM02 1200	F03FS02819
350	3,0	2,2	60	24+2+2	4CH 21x5	LM02 1300	F03FS02821
350	3,0	2,2	70	24+2+2	4CH 21x5	LM02 1400	F03FS02823
350	3,0	2,2	80	24+2+2	2CH 13x5+2CH 21x5	LM02 1500	F03FS02825

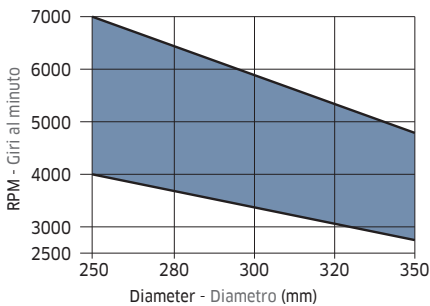

Minimum and maximum RPM based on the blade diameter.  
Fascia del N. giri minimo e massimo consigliati in funzione del diametro della lama.

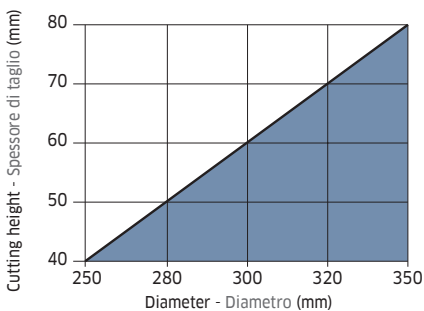

Maximum depth of cut based on the blade diameter.  
Altezza di taglio massima consentita in funzione del diametro della lama.

■ Solid wood  
■ Legno massiccio

Ultimate Eccellente	High Ottimo	Good Buono
	●	
	●	

Ripping of softwood  
Legno tenero lungo vena  
Ripping of hardwood  
Legno duro lungo vena

# LM03

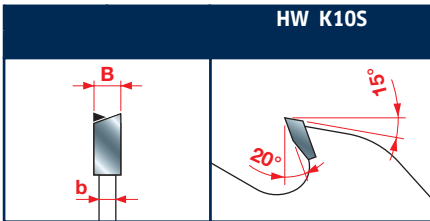
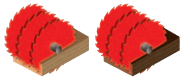
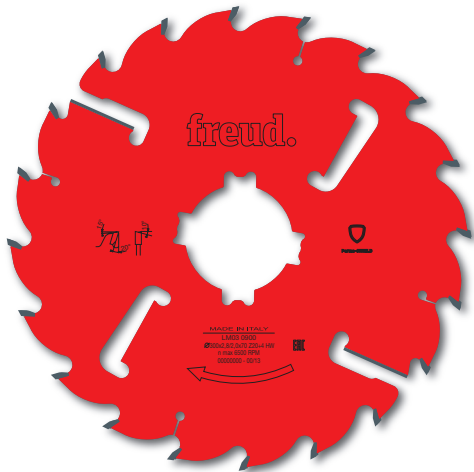

Tooth features - Caratteristiche del dente

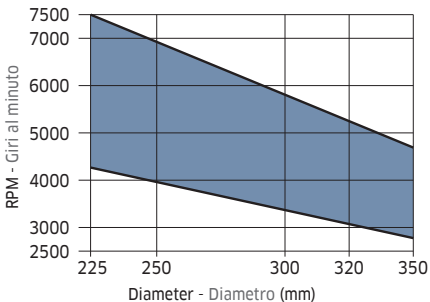

Minimum and maximum RPM based on the blade diameter.  
Fascia del N. giri minimo e massimo consigliati in funzione del diametro della lama.

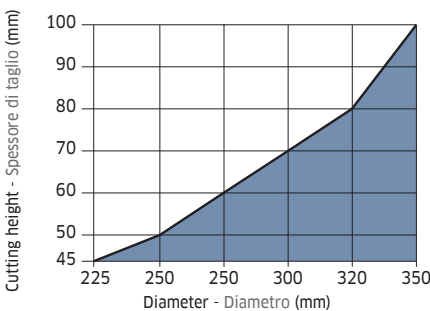

Maximum depth of cut based on the blade diameter.  
Altezza di taglio massima consentita in funzione del diametro della lama.

■ Solid wood  
■ Legno massiccio

## HW - Reduced kerf saw blades with rakers HW - Lama a spessore ridotto con denti stabilizzatori

Saw blades suitable for ripping where the thin body greatly reduces material wastes. Not suitable for cutting poplar.

**Machines:** Multiripping machines.

**Features:** ATB 10° tooth.

**Material:** Soft and hard wood dried at max 15% humidity rate.

Lame per tagli longitudinali. Lo spessore sottile consente di ridurre gli scarti del materiale. La lama non è idonea per lavorare il popolo.

**Macchine:** Multilame mono e bialbero.

**Caratteristiche:** Dentatura alterna a 10°.

**Materiale:** Legni teneri e duri essiccati con umidità max del 15%.

D mm	B mm	b mm	d mm	Z	KN CH	Code Codice	SAP SAP
225	2,5	1,8	70	16+2+2	4CH 21x5	LM03 0100	F03FS02843
250	2,8	2,0	30	16+2+2	2CH 10x4	LM03 0200	F03FS02845
250	2,8	2,0	60	16+2+2	4CH 21x5	LM03 0300	F03FS02847
250	2,8	2,0	70	16+2+2	4CH 21x5	LM03 0400	F03FS02849
250	2,8	2,0	80	16+2+2	2CH 13x5+2CH 21x5	LM03 0500	F03FS02851
280	2,8	2,0	80	18+2+2	2CH 13x5+2CH 21x5	LM03 0600	F03FS02853
300	2,8	2,0	30	20+2+2	2CH 10x4	LM03 0700	F03FS02855
300	2,8	2,0	60	20+2+2	4CH 21x5	LM03 0800	F03FS02857
300	2,8	2,0	70	20+2+2	4CH 21x5	LM03 0900	F03FS02859
300	2,8	2,0	80	20+2+2	2CH 13x5+2CH 21x5	LM03 1000	F03FS02861
320	3,0	2,2	30	20+2+2	2CH 10x4	LM03 1100	F03FS02863
320	3,0	2,2	80	20+2+2	2CH 13x5+2CH 21x5	LM03 1200	F03FS02865
350	3,0	2,2	30	24+2+2	2CH 10x4	LM03 1300	F03FS02867
350	3,0	2,2	60	24+2+2	4CH 21x5	LM03 1400	F03FS02869
350	3,0	2,2	70	24+2+2	4CH 21x5	LM03 1500	F03FS02871
350	3,0	2,2	80	24+2+2	2CH 13x5+2CH 21x5	LM03 1600	F03FS02873
350	3,0	2,2	90	24+2+2	4CH 20x7	LM03 1700	F03FS05808

Ultimate Eccellente	High Ottimo	Good Buono
	●	
	●	

Ripping of softwood  
Legno tenero lungo vena

Ripping of hardwood  
Legno duro lungo vena

# LM04

## HW - Ripping saw blades with rakers HW - Lama a spessore normale con denti stabilizzatori

Saw blades suitable for ripping.

**Machines:** Multiripping machines.

**Features:** ATB 10° tooth.

**Material:** Soft and hard wood dried at 15% humidity rate.

Lame per tagli longitudinali.

**Macchine:** Multilame mono e bialbero.

**Caratteristiche:** Dentatura alterna a 10°.

**Materiale:** Legni teneri e duri essiccati con umidità max del 15%.

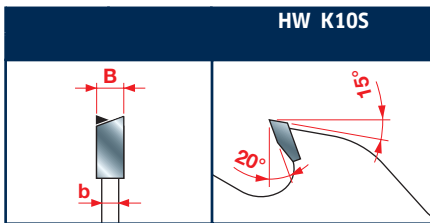
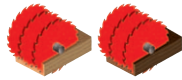

Tooth features - Caratteristiche del dente

D mm	B mm	b mm	d mm	Z	KN CH	Code Codice	SAP SAP
250	3,2	2,2	30	20+2+2	2CH 10x4	LM04 0100	F03FS02891
250	3,2	2,2	60	20+2+2	4CH 21x5	LM04 0200	F03FS02893
250	3,2	2,2	70	20+2+2	4CH 21x5	LM04 0300	F03FS02895
250	3,2	2,2	80	20+2+2	2CH 13x5+2CH 21x5	LM04 0400	F03FS02897
300	3,2	2,2	30	24+2+2	2CH 10x4	LM04 0500	F03FS02899
300	3,2	2,2	60	24+2+2	4CH 21x5	LM04 0600	F03FS02901
300	3,2	2,2	70	24+2+2	4CH 21x5	LM04 0700	F03FS02903
300	3,2	2,2	80	24+2+2	2CH 13x5+2CH 21x5	LM04 0800	F03FS02906
320	3,2	2,2	30	24+2+2	2CH 10x4	LM04 0900	F03FS02908
320	3,2	2,2	80	24+2+2	2CH 13x5+2CH 21x5	LM04 1000	F03FS02910
350	3,5	2,5	70	24+2+4	4CH 21x5	LM04 2400	F03FS06243
350	3,5	2,5	80	24+2+4	2CH 13x5+2CH 21x5	LM04 2500	F03FS06244
350	3,5	2,5	30	28+2+4	2CH 10x4	LM04 1100	F03FS02912
350	3,5	2,5	60	28+2+4	4CH 21x5	LM04 1200	F03FS02914
350	3,5	2,5	70	28+2+4	4CH 21x5	LM04 1300	F03FS02916
350	3,5	2,5	80	28+2+4	2CH 13x5+2CH 21x5	LM04 1400	F03FS02919
350	3,5	2,5	90	28+2+4	4CH 21x5	LM04 2200	F03FS02935
400	4,0	2,8	30	28+2+4		LM04 1500	F03FS02921
400	4,0	2,8	70	28+2+4	4CH 21x5	LM04 1600	F03FS02923
400	4,0	2,8	80	28+2+4	2CH 13x5+2CH 21x5	LM04 1700	F03FS02926

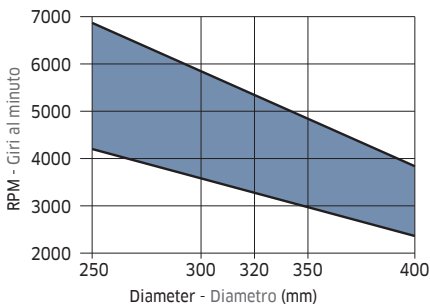

Minimum and maximum RPM based on the blade diameter.  
Fascia del N. giri minimo e massimo consigliati in funzione del diametro della lama.

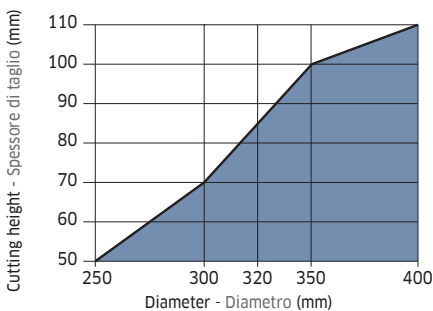

Maximum depth of cut based on the blade diameter.  
Altezza di taglio massima consentita in funzione del diametro della lama.

■ Solid wood  
■ Legno massiccio

Ultimate Eccellente	High Ottimo	Good Buono
	●	
	●	

Ripping of softwood  
Legno tenero lungo vena  
Ripping of hardwood  
Legno duro lungo vena

# LM05

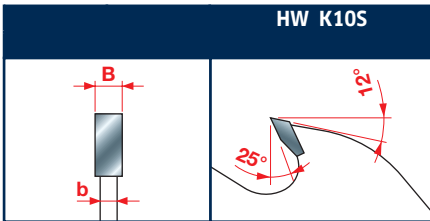
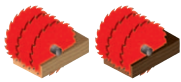

Tooth features - Caratteristiche del dente

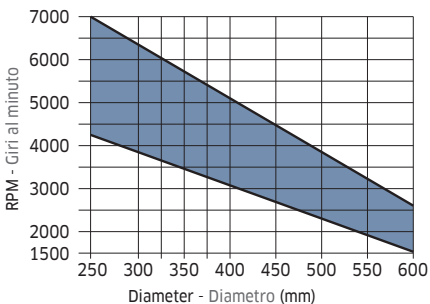

Minimum and maximum RPM based on the blade diameter.  
Fascia del N. giri minimo e massimo consigliati in funzione del diametro della lama.

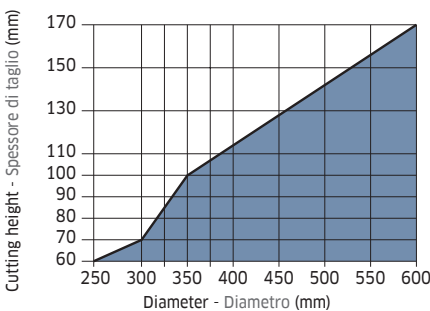

Maximum depth of cut based on the blade diameter.  
Altezza di taglio massima consentita in funzione del diametro della lama.

Solid wood  
Legno massiccio

## HW - Ripping saw blades with rakers HW - Lama a spessore normale con denti stabilizzatori

Saw blades for ripping extra thick timber. Particularly suitable in sawmills for cutting wood with humidity rate over 10%.

**Machines:** Multiripping machines.

**Features:** Flat tooth.

**Material:** Soft and hard wood and long fibre wood.

Lame per tagli longitudinali di legni con elevato spessore. Indicata in particolare modo nelle segherie per il taglio di legni umidi oltre il 10%.

**Macchine:** Multilame mono e bialbero.

**Caratteristiche:** Dentatura piana.

**Materiale:** Legni teneri e duri umidi e a fibra lunga.

D mm	B mm	b mm	d mm	Z	KN CH	Code Codice	SAP SAP
250	3,4	2,2	30	16+2+2	2CH 10x4	LM05 0100	F03FS02973
250	3,4	2,2	60	16+2+2	4CH 21x5	LM05 0200	F03FS02975
250	3,4	2,2	70	16+2+2	4CH 21x5	LM05 0300	F03FS02977
250	3,4	2,2	80	16+2+2	2CH 13x5+2CH 21x5	LM05 0400	F03FS02979
300	3,4	2,2	30	20+2+2	2CH 10x4	LM05 0500	F03FS02981
300	3,4	2,2	60	20+2+2	4CH 21x5	LM05 0600	F03FS02983
300	3,4	2,2	70	20+2+2	4CH 21x5	LM05 0700	F03FS02985
300	3,4	2,2	80	20+2+2	2CH 13x5+2CH 21x5	LM05 0800	F03FS02990
320	3,4	2,2	30	20+2+2	2CH 10x4	LM05 0900	F03FS02993
320	3,4	2,2	80	20+2+2	2CH 13x5+2CH 21x5	LM05 1000	F03FS02995
350	3,7	2,5	30	20+2+4	2CH 10x4	LM05 1100	F03FS02997
350	3,7	2,5	50	20+2+4	2CH 10x4	LM05 1200	F03FS02999
350	3,7	2,5	60	20+2+4	4CH 21x5	LM05 1300	F03FS03001
350	3,7	2,5	70	20+2+4	4CH 21x5	LM05 1400	F03FS03003
350	3,7	2,5	80	20+2+4	2CH 13x5+2CH 21x5	LM05 1500	F03FS03005
350	3,7	2,5	90	20+2+4	4CH 21x5	LM05 4100	F03FS03060
380	4,0	2,8	30	20+2+4	2CH 10x4	LM05 1600	F03FS03007
380	4,0	2,8	70	20+2+4	4CH 21x5	LM05 1700	F03FS03009
380	4,0	2,8	80	20+2+4	2CH 13x5+2CH 21x5	LM05 1800	F03FS03011
400	4,0	2,8	30	24+2+4	2CH 10x4	LM05 1900	F03FS03013
400	4,0	2,8	50	24+2+4	2CH 10x4	LM05 2000	F03FS03015
400	4,0	2,8	70	24+2+4	4CH 21x5	LM05 2100	F03FS03017
400	4,0	2,8	80	24+2+4	2CH 13x5+2CH 21x5	LM05 2200	F03FS03019
450	4,4	3,0	30	24+2+4	2CH 10x4	LM05 2400	F03FS03023
450	4,4	3,0	50	24+2+4		LM05 2500	F03FS03025
450	4,4	3,0	70	24+2+4	4CH 21x5	LM05 2600	F03FS03027
450	4,4	3,0	80	24+2+4	2CH 13x5+2CH 21x5	LM05 2700	F03FS03029
500	4,8	3,5	30	28+2+4		LM05 2900	F03FS03033
500	4,8	3,5	50	28+2+4	2CH 10x4	LM05 3000	F03FS03036
500	4,8	3,5	70	28+2+4	4CH 21x5	LM05 3100	F03FS03039
500	4,8	3,5	80	28+2+4	2CH 13x5+2CH 21x5	LM05 3200	F03FS03041
550	4,8	3,5	30	28+2+4	2CH 10x4	LM05 3400	F03FS03045
550	4,8	3,5	50	28+2+4	2CH 10x4	LM05 3500	F03FS03047
550	4,8	3,5	70	28+2+4	4CH 21x5	LM05 3600	F03FS03050
550	4,8	3,5	80	28+2+4	2CH 13x5+2CH 21x5	LM05 3700	F03FS03052
600	5,2	3,5	30	32+2+4	2CH 10x4	LM05 4200	F03FS05860
600	5,2	3,5	80	32+2+4	4CH 21x5	LM05 3900	F03FS03056

Ultimate Eccellente	High Ottimo	Good Buono
	●	
	●	

Ripping of softwood  
Legno tenero lungo vena  
Ripping of hardwood  
Legno duro lungo vena

# LM06

## HW - Ripping saw blades with rakers HW - Lama a spessore maggiorato con denti stabilizzatori

Saw blades for ripping extra thick timber. Most suitably employed in sawmills when cutting wet wood and with a high resin content.

**Machines:** Multiripping machines.

**Features:** Flat tooth.

**Material:** Humid over 10% soft and hard wood and long fibre wood.

Lame per tagli longitudinali di legni con altezza di taglio maggiorato. Indicata in particolar modo nelle segherie per il taglio di legni umidi e molto resinosi.

**Macchine:** Multilame mono e bialbero.

**Caratteristiche:** Dentatura piana.

**Materiale:** Legni teneri e duri umidi oltre il 10% e a fibra lunga.

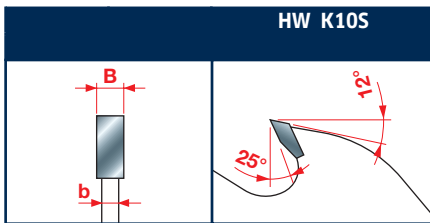
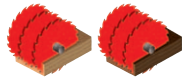

Tooth features - Caratteristiche del dente

D	B	b	d	Z	KN	Code	SAP
mm	mm	mm	mm		CH	Codice	SAP
250	4,2	3,0	30	16+2+2	2CH 10x4	LM06 0100	F03FS03104
250	4,2	3,0	60	16+2+2	4CH 21x5	LM06 0200	F03FS03106
250	4,2	3,0	70	16+2+2	4CH 21x5	LM06 0300	F03FS03108
250	4,2	3,0	80	16+2+2	4CH 21x5	LM06 0400	F03FS03110
300	3,5	2,5	70	20+2+2	4CH 21x5	LM06 1500	F03FS03133
300	3,5	2,5	80	20+2+2	2CH 13x5+2CH 21x5	LM06 1600	F03FS03135
300	4,2	3,0	30	20+2+2	2CH 10x4	LM06 0500	F03FS03113
300	4,2	3,0	60	20+2+2	4CH 21x5	LM06 0600	F03FS03115
300	4,2	3,0	70	20+2+2	4CH 21x5	LM06 0700	F03FS03117
300	4,2	3,0	80	20+2+2	2CH 13x5+2CH 21x5	LM06 0800	F03FS03119
320	4,2	3,0	30	20+2+2	2CH 10x4	LM06 0900	F03FS03121
320	4,2	3,0	70	20+2+2	4CH 21x5	LM06 1900	F03FS03140
320	4,2	3,0	80	20+2+2	2CH 13x5+2CH 21x5	LM06 1000	F03FS03123
350	4,2	3,0	30	20+2+4	2CH 10x4	LM06 1100	F03FS03125
350	4,2	3,0	50	20+2+4	2CH 10x4	LM06 1800	F03FS03138
350	4,2	3,0	60	20+2+4	4CH 21x5	LM06 1200	F03FS03127
350	4,2	3,0	70	20+2+4	4CH 21x5	LM06 1300	F03FS03129
350	4,2	3,0	80	20+2+4	2CH 13x5+2CH 21x5	LM06 1400	F03FS03131

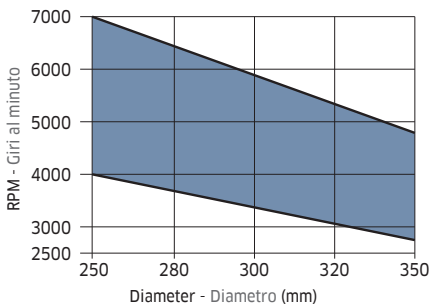

Minimum and maximum RPM based on the blade diameter.

Fascia del N. giri minimo e massimo consigliati in funzione del diametro della lama.

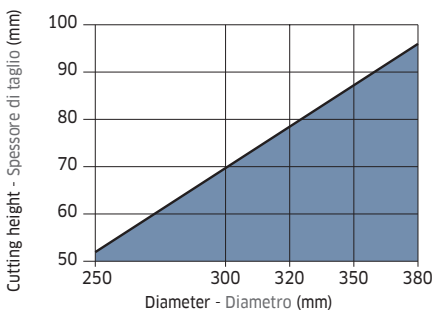

Maximum depth of cut based on the blade diameter. Altezza di taglio massima consentita in funzione del diametro della lama.

■ Solid wood  
■ Legno massiccio

Ultimate Eccellente	High Ottimo	Good Buono
	●	
	●	

Ripping of softwood  
Legno tenero lungo vena

Ripping of hardwood  
Legno duro lungo vena

# LM07

## HW - Shoulder thick kerf saw blades with rakers HW - Lama a grosso spessore con denti stabilizzatori (lame di spalla)

Saw blades for ripping. Essential for ensuring correct distribution of lateral forces created by crooked plank in heavy duty use. Use as a shoulder saw blade on multirip machines.

**Machines:** Multiripping machines.

**Features:** Flat tooth.

**Material:** Solid hard and soft wood, dried and wet.

Lame per tagli longitudinali. Montate sui lati, in pacco con le lame di sezionatura, per la refilatura e per i tagli perimetrali.

**Macchine:** Multilame mono e bialbero.

**Caratteristiche:** Dentatura piana.

**Materiale:** Legni teneri e duri umidi o essiccati.

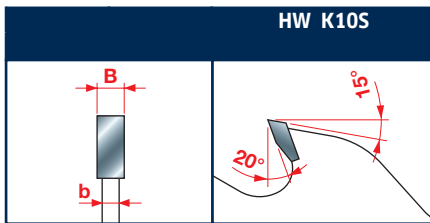
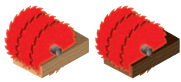

Tooth features - Caratteristiche del dente

D mm	B mm	b mm	d mm	Z	KN CH	Code Codice	SAP SAP
250	5,5	3,5	30	16+2+2	2CH 10x4	LM07 0100	F03FS03141
250	5,5	3,5	60	16+2+2	4CH 21x5	LM07 0200	F03FS03143
250	5,5	3,5	70	16+2+2	4CH 21x5	LM07 0300	F03FS03145
250	5,5	3,5	80	16+2+2	2CH 13x5+2CH 21x5	LM07 0400	F03FS03147
300	5,5	3,5	30	20+2+2	2CH 10x4	LM07 0500	F03FS03149
300	5,5	3,5	60	20+2+2	4CH 21x5	LM07 0600	F03FS03151
300	5,5	3,5	70	20+2+2	4CH 21x5	LM07 0700	F03FS03153
300	5,5	3,5	80	20+2+2	2CH 13x5+2CH 21x5	LM07 0800	F03FS03155
320	5,5	3,5	30	20+2+2	2CH 10x4	LM07 0900	F03FS03157
320	5,5	3,5	80	20+2+2	2CH 13x5+2CH 21x5	LM07 1000	F03FS03159
350	5,5	3,5	30	24+2+4	2CH 10x4	LM07 1100	F03FS03161
350	5,5	3,5	60	24+2+4	4CH 21x5	LM07 1200	F03FS03163
350	5,5	3,5	70	24+2+4	4CH 21x5	LM07 1300	F03FS03165
350	5,5	3,5	80	24+2+4	4CH 21x5	LM07 1400	F03FS03167

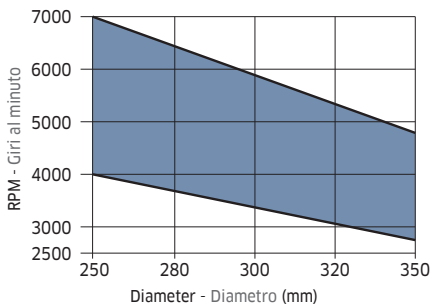

Minimum and maximum RPM based on the blade diameter.  
Fascia del N. giri minimo e massimo consigliati in funzione del diametro della lama.

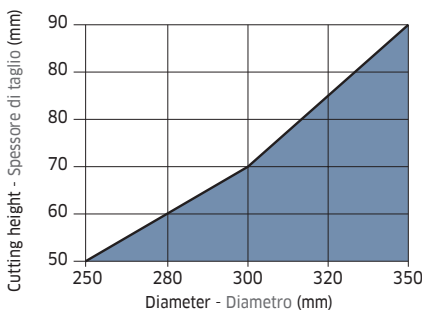

Maximum depth of cut based on the blade diameter.  
Altezza di taglio massima consentita in funzione del diametro della lama.

■ Solid wood  
■ Legno massiccio

Ultimate Eccellente	High Ottimo	Good Buono
	●	
	●	

Ripping of softwood  
Legno tenero lungo vena  
Ripping of hardwood  
Legno duro lungo vena

# LM08

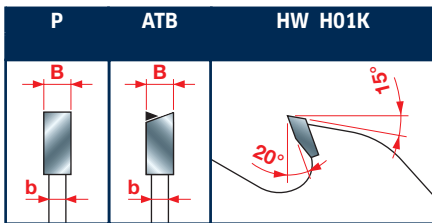
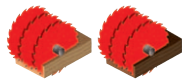

Tooth features - Caratteristiche del dente

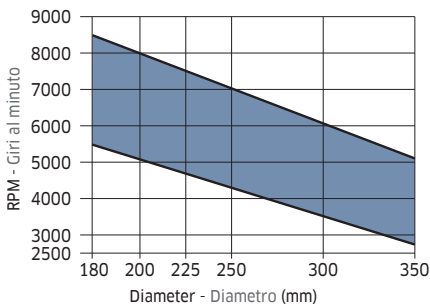

Minimum and maximum RPM based on the blade diameter.

Fascia del N. giri minimo e massimo consigliati in funzione del diametro della lama.

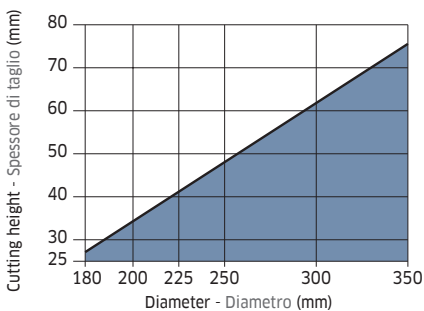

Maximum depth of cut based on the blade diameter.

Altezza di taglio massima consentita in funzione del diametro della lama.

■ Solid wood  
■ Legno massiccio

## HW - Ultra-thin kerf saw blades HW - Lama a spessore ultrasottile

Saw blades for ripping, mostly suited when wastes must be brought down to a minimum. **Reboring and keyways optional not available. We recommend the saw blade to be regularly cleaned in order to prevent the formation of resin deposits.**

**Machines:** Moulders and cleaving machines.

**Features:** Flat tooth (P) or ATB 15° tooth.

**Material:** Good quality soft and hard wood dried at max 10% humidity rate.

Lame per tagli longitudinali, particolarmente indicata nel caso in cui sia richiesto di ridurre al minimo gli scarti di materiale. **Non si esegue allargatura di fori e chiavette optional. Si raccomanda una frequente pulizia del corpo lama dai depositi di resina.**

**Macchine:** Scorniatrici, spaccatrici.

**Caratteristiche:** Dentatura piana (P) o alterna (ATB) a 15°.

**Materiale:** Legni pregiati teneri e duri essiccati con umidità max del 10%.

D	B	b	d	Z	NL - KN FT - CH	Code Codice	SAP SAP
180	1,5	1,0	40	24	P	2CH 12x5	LM08 0100 F03FS03169
180	1,5	1,0	60	24	P	FT 3/10/75	LM08 0200 F03FS03171
200	1,5	1,0	40	28	P	2CH 12x5	LM08 0300 F03FS03173
200	1,5	1,0	60	28	P	FT 3/10/75	LM08 0400 F03FS03176
200	1,5	1,0	60	36	ATB	FT 3/10/75	LM08 0500 F03FS03179
200	1,7	1,2	50	36	ATB		LM08 0600 F03FS03182
200	1,7	1,2	60	36	ATB	FT 3/10/75	LM08 2800 F03FS03240
225	1,5	1,0	40	28	P	2CH 12x5	LM08 0700 F03FS03185
225	1,5	1,0	60	28	P	FT 3/10/75	LM08 0800 F03FS03188
225	1,5	1,0	70	28	P	2CH 21x5	LM08 0900 F03FS03191
225	1,5	1,0	40	36	ATB	2CH 12x5	LM08 1000 F03FS03194
225	1,5	1,0	60	36	ATB	FT 3/10/75	LM08 1100 F03FS03197
225	1,5	1,0	70	36	ATB	2CH 21x5	LM08 1200 F03FS03200
225	1,7	1,2	65	36	ATB	FT 3/10/80	LM08 1300 F03FS03203
250	1,7	1,2	40	24	P	2CH 12x5	LM08 1400 F03FS03206
250	1,7	1,2	60	24	P	FT 3/10/75	LM08 1500 F03FS03209
250	1,7	1,2	70	24	P	2CH 21x5	LM08 1600 F03FS03212
250	1,7	1,2	40	36	ATB	2CH 12x5	LM08 1700 F03FS03215
250	1,7	1,2	60	36	ATB	FT 3/10/75	LM08 1800 F03FS03218
250	1,7	1,2	70	36	ATB	2CH 21x5	LM08 1900 F03FS03223
250	2,2	1,6	50	30	ATB	2CH 21x5	LM08 2500 F03FS03237
250	2,2	1,6	60	30	ATB	2CH 21x5	LM08 2600 F03FS03238
250	2,2	1,6	70	30	ATB	2CH 21x5	LM08 2700 F03FS03239
255	1,7	1,2	70	24	P	2CH 21x5	LM08 2400 F03FS03236
280	2,2	1,6	60	36	ATB	FT 3/10/75	LM08 2200 F03FS03232
300	2,2	1,6	50	36	ATB		LM08 2000 F03FS03226
300	2,2	1,6	70	36	ATB	2CH 21x5	LM08 2300 F03FS03235
350	2,5	1,8	50	40	ATB		LM08 2100 F03FS03229

Ultimate Eccellente	High Ottimo	Good Buono
	●	
	●	

Ripping of softwood  
Legno tenero lungo vena  
Ripping of hardwood  
Legno duro lungo vena

# LU1A

## HW - Saw blades for radial and pendulum machines HW - Lame per macchine radiali e a pendolo

Saw blades suitable for crosscutting.

**Machines:** Radial, pendulum and portable machines.

**Features:** ATB 15° tooth with negative cutting angle.

**Material:** Soft, hard, dried and wet solid wood.

Lame per taglio trasverso vena.

**Macchine:** Radiali, a pendolo, macchine portatili.

**Caratteristiche:** Dentatura alterna a 15° con angolo di taglio negativo.

**Materiale:** Legni massicci teneri, duri, secchi e umidi.

**FT02:** 2/9/46,4 + 2/10/60

**FT03:** 2/7/42 + 2/10/60

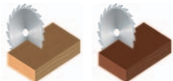

D mm	B mm	b mm	d mm	Z	NL FT	Code Codice	SAP SAP
300	4,4	3,0	30	36	FT02	<b>LU1A 0100</b>	F03FS04572
350	4,4	3,0	30	42	2/10/60	<b>LU1A 0200</b>	F03FS04573
400	4,4	3,0	30	48	FT02	<b>LU1A 0300</b>	F03FS04574
450	4,4	3,0	30	54	FT03	<b>LU1A 0400</b>	F03FS04575
500	4,8	3,2	30	60	2/10/60	<b>LU1A 0500</b>	F03FS04576
550	4,8	3,2	30	72	2/10/60	<b>LU1A 0600</b>	F03FS04577
600	5,0	3,5	30	72	FT02	<b>LU1A 0700</b>	F03FS04578

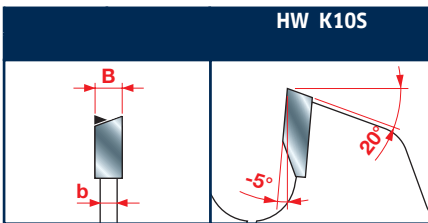

Tooth features - Caratteristiche del dente

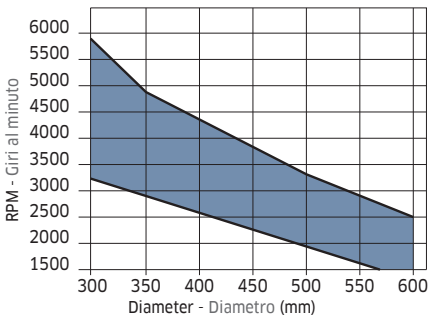

Minimum and maximum RPM based on the blade diameter.  
Fascia del N. giri minimo e massimo consigliati in funzione del diametro della lama.

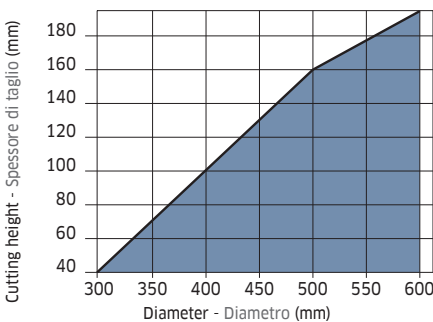

Maximum depth of cut based on the blade diameter.  
Altezza di taglio massima consentita in funzione del diametro della lama.

■ Solid wood  
■ Legno massiccio

### Working with spindle over the workpiece Lavorazione con albero sopra il piano di lavoro

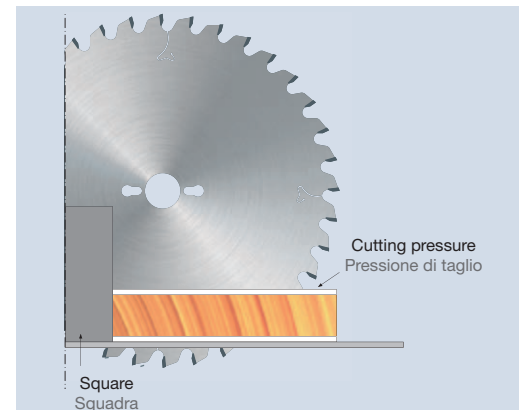

Ultimate Eccellente	High Ottimo	Good Buono
		●
		●

Cross cutting of softwood  
Legno tenero trasverso vena  
Cross cutting of hardwood  
Legno duro trasverso vena

# LU1B

## HW - Saw blades for carpentry works HW - Lame per carpenteria

Saw blades suitable for ripping and crosscutting.

**Machines:** Table saws, portable machines.

**Features:** ATB/bevelled tooth with positive cutting angle.

**Material:** Soft and hard solid wood and panels, even in case of nails or metal clips.

Lame per taglio lungo e trasverso vena.

**Macchine:** Seghe da banco, macchine portatili.

**Caratteristiche:** Dente piano smussato/alterno con angolo di taglio positivo.

**Materiale:** Legni teneri e duri massicci e pannelli, anche con presenza di chiodi o graffe metalliche.

**FT01:** 2/7/42 + 2/9/46,4 + 2/10/60

**FT02:** 2/9/46,4 + 2/10/60

**FT03:** 2/7/42 + 2/10/60



### HW K10S

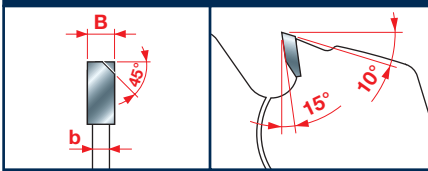

Tooth features - Caratteristiche del dente

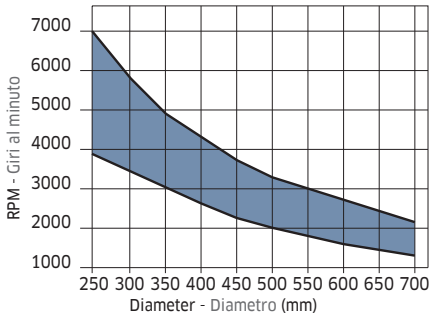

Minimum and maximum RPM based on the blade diameter.

Fascia del N. giri minimo e massimo consigliati in funzione del diametro della lama.

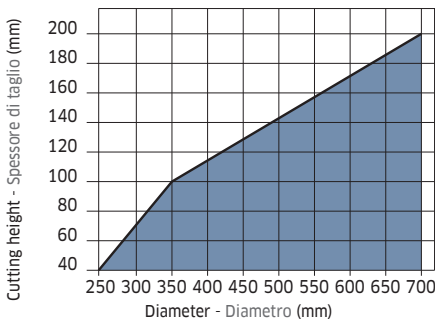

Maximum depth of cut based on the blade diameter.  
Altezza di taglio massima consentita in funzione del diametro della lama.

■ Solid wood  
■ Legno massiccio

D mm	B mm	b mm	d mm	Z	NL FT	Code Codice	SAP SAP
250	3,4	2,2	30	18	FT01	LU1B 0100	F03FS04579
300	3,4	2,2	30	20	FT01	LU1B 0200	F03FS04580
315	3,4	2,2	30	20	FT01	LU1B 0300	F03FS04582
350	3,7	2,5	30	24	FT02	LU1B 0400	F03FS04583
400	4,0	2,8	30	28	2/10/60	LU1B 0500	F03FS04585
450	4,2	3,0	30	32	FT03	LU1B 0600	F03FS04586
500	4,4	3,2	30	36	FT03	LU1B 0700	F03FS04587
550	4,8	3,5	30	44	2/10/60	LU1B 0800	F03FS04588
600	5,2	4,0	30	48	FT03	LU1B 0900	F03FS04589
650	5,2	3,8	30	54	FT02	LU1B 1000	
700	5,6	4,2	30	60	2/5/60	LU1B 1100	F03FS05892

Ultimate Eccellente	High Ottimo	Good Buono
		●
		●

Ripping and cross cutting of softwood  
Legno tenero lungo e trasverso vena

Ripping and cross cutting of hardwood  
Legno duro lungo e trasverso vena

# LU1C

## HW - Saw blades to cut solid wood HW - Lame per il taglio di legni massicci

Saw blades suitable for ripping.

**Machines:** Table saws, multiripping machines.

**Features:** ATB 10° tooth with positive cutting angle.

**Material:** Soft and hard solid wood, also with loose knots.

Lame per taglio lungo vena.

**Macchine:** Seghe da banco, multilame.

**Caratteristiche:** Dentatura alterna a 10° con angolo di taglio positivo.

**Materiale:** Legni teneri e duri massicci anche con nodi cascanti.

**FT01:** 2/7/42 + 2/9/46,4 + 2/10/60

**FT02:** 2/9/46,4 + 2/10/60

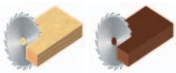

HW H01K

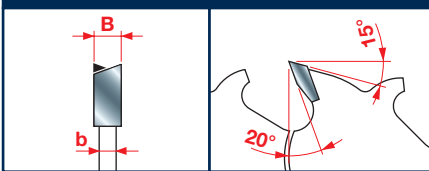

Tooth features - Caratteristiche del dente

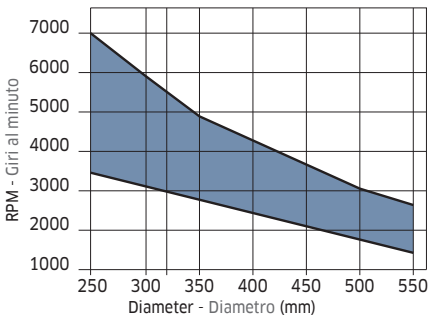

Minimum and maximum RPM based on the blade diameter.  
Fascia del N. giri minimo e massimo consigliati in funzione del diametro della lama.

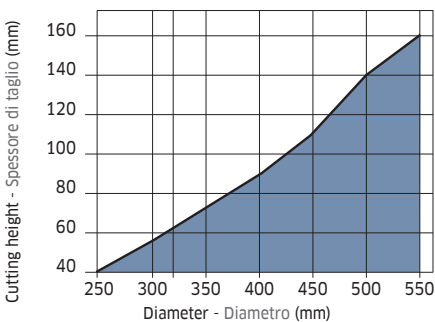

Maximum depth of cut based on the blade diameter.  
Altezza di taglio massima consentita in funzione del diametro della lama.

■ Solid wood  
■ Legno massiccio

	D	B	b	d	Z	NL - KN	Code	SAP
	mm	mm	mm	mm		FT - CH	Code	SAP
250	3,2	2,2	30	22	22	FT01	LU1C 0100	F03FS04590
250	3,2	2,2	70	22	22	4CH 21x5	LU1C 0200	F03FS04592
300	3,2	2,2	30	26	26	FT01	LU1C 0400	F03FS04595
300	3,2	2,2	35	26	26		LU1C 0500	F03FS04597
300	3,2	2,2	70	26	26	4CH 21x5	LU1C 0700	F03FS04599
315	3,2	2,2	30	28	28	FT01	LU1C 0800	F03FS04601
350	3,5	2,5	30	30	30	FT02	LU1C 1000	F03FS04603
350	3,5	2,5	35	30	30		LU1C 1100	F03FS04605
350	3,5	2,5	70	30	30	4CH 21x5	LU1C 1200	F03FS04607
400	4,0	2,8	30	34	34	2/10/60	LU1C 1300	F03FS04609
450	4,4	3,0	30	38	38	2/10/60	LU1C 1400	F03FS04611
500	4,4	3,2	30	42	42	2/10/60	LU1C 1500	F03FS04612
550	4,4	3,5	30	48	48	2/10/60	LU1C 1600	F03FS04613

	Ultimate Eccellente	High Ottimo	Good Buono
Ripping of softwood Legno tenero lungo vena		●	
Ripping of hardwood Legno duro lungo vena		●	

# LU1D

## HW - Saw blades to cut solid wood HW - Lame per il taglio di legni massicci

Saw blades suitable for ripping.

**Machines:** Table saws, multiripping machines.

**Features:** ATB 10° tooth with positive cutting angle.

**Material:** Soft, hard and exotic solid wood without loose knots.

Lame per taglio lungo vena.

**Macchine:** Seghe da banco, multilame.

**Caratteristiche:** Dentatura alterna a 10° con angolo di taglio positivo.

**Materiale:** Legni massicci teneri, duri, esotici senza nodi cascanti.

**FT01:** 2/7/42 + 2/9/46,4 + 2/10/60

**FT02:** 2/9/46,4 + 2/10/60

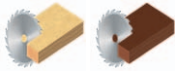

	D mm	B mm	b mm	d mm	Z	NL - KN FT - CH	Code Codice	SAP SAP
	250	3,2	2,2	30	24	FT01	<b>LU1D 0100</b>	F03FS04615
	250	3,2	2,2	70	24	4CH 21x5	<b>LU1D 0200</b>	F03FS04617
	300	3,2	2,2	30	28	FT01	<b>LU1D 0500</b>	F03FS04620
	300	3,2	2,2	60	28	4CH 21x5	<b>LU1D 0600</b>	F03FS04622
	300	3,2	2,2	70	28	4CH 21x5	<b>LU1D 0800</b>	F03FS04624
	350	3,5	2,5	30	32	FT02	<b>LU1D 1100</b>	F03FS04628
	350	3,5	2,5	70	32	4CH 21x5	<b>LU1D 1000</b>	F03FS04626

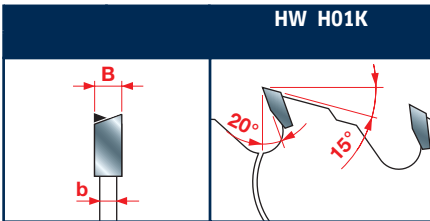

Tooth features - Caratteristiche del dente

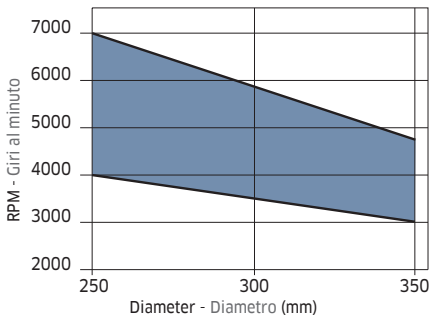

Minimum and maximum RPM based on the blade diameter.

Fascia del N. giri minimo e massimo consigliati in funzione del diametro della lama.

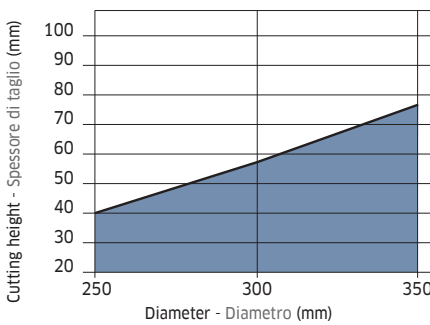

Maximum depth of cut based on the blade diameter.  
Altezza di taglio massima consentita in funzione del diametro della lama.

Solid wood  
Legno massiccio

Ultimate Eccellente	High Ottimo	Good Buono

Ripping of softwood  
Legno tenero lungo vena  
Ripping of hardwood  
Legno duro lungo vena

# LU1E

## HW - Saw blades to cut solid wood - Thin kerf HW - Lame per il taglio di legni massicci - Sp. sottile

Saw blades suitable for ripping. The reduced cutting height makes workpiece feeding easier.

**Machines:** Table saws, portable machines.

**Features:** Flat tooth with positive cutting angle and anti-kickback device.

**Material:** Soft and hard dried wood, also with loose knots.

Lame per taglio lungo vena. Lo spessore di taglio ridotto facilita l'avanzamento del pezzo da lavorare.

**Macchine:** Seghe da banco, macchine portatili.

**Caratteristiche:** Dente piano con angolo di taglio positivo e limitatore di truciolo.

**Materiale:** Legni pregiati essiccati teneri e duri anche con nodi cascanti.

**FT01:** 2/7/42 + 2/9/46,4 + 2/10/60

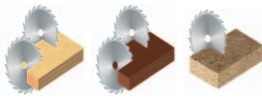

	D mm	B mm	b mm	d mm	Z	NL FT	Code Codice	SAP SAP
	250	2,5	1,6	30	24	FT01	<b>LU1E 0100</b>	F03FS04630
	300	2,6	1,8	30	24		<b>LU1E 0500</b>	F03FS04638
	300	2,7	1,8	25	28		<b>LU1E 0200</b>	F03FS04632
	300	2,7	1,8	30	28	FT01	<b>LU1E 0300</b>	F03FS04634
	350	3,0	2,2	30	32	FT01	<b>LU1E 0400</b>	F03FS04636

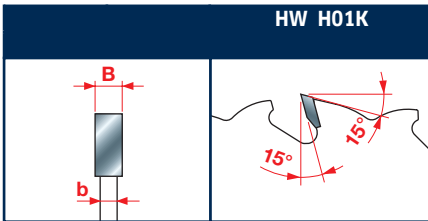

Tooth features - Caratteristiche del dente

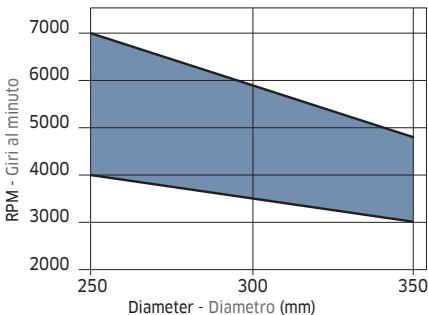

Minimum and maximum RPM based on the blade diameter.  
Fascia del N. giri minimo e massimo consigliati in funzione del diametro della lama.

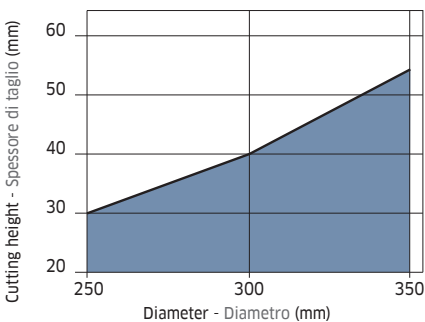

Maximum depth of cut based on the blade diameter.  
Altezza di taglio massima consentita in funzione del diametro della lama.

Solid wood  
Legno massiccio

	Ultimate Eccellente	High Ottimo	Good Buono
Ripping of solid wood Legno massiccio lungo vena		●	
Cross cutting of solid wood Legno massiccio trasverso vena			●
Wood composites Composti di legno			●

# LU1F

## HW - Saw blades to cut solid wood - Thin kerf HW - Lama per il taglio di legni massicci - Sp. sottile

Saw blades suitable for ripping. The reduced cutting height makes workpiece feeding easier.

**Machines:** Table saws, portable machines.

**Features:** ATB 10° tooth with positive cutting angle.

**Material:** Soft and hard dried wood, without loose knots.

Lame per taglio lungo vena. Lo spessore di taglio ridotto facilita l'avanzamento del pezzo da lavorare.

**Macchine:** Seghe da banco, macchine portatili.

**Caratteristiche:** Dentatura alterna a 10° con angolo di taglio positivo.

**Materiale:** Legni pregiati essiccati teneri e duri senza nodi cascanti.

**FT01:** 2/7/42 + 2/9/46,4 + 2/10/60

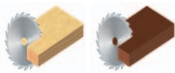

	D mm	B mm	b mm	d mm	Z	NL FT	Code Codice	SAP SAP
	250	2,5	1,6	30	24	FT01	<b>LU1F 0100</b>	F03FS04640
	300	2,7	1,8	30	28	FT01	<b>LU1F 0200</b>	F03FS04642
	350	3,0	2,2	30	32	FT01	<b>LU1F 0300</b>	F03FS04644

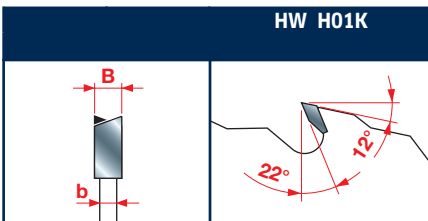

Tooth features - Caratteristiche del dente

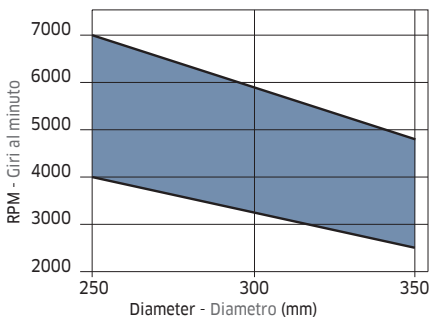

Minimum and maximum RPM based on the blade diameter.  
Fascia del N. giri minimo e massimo consigliati in funzione del diametro della lama.

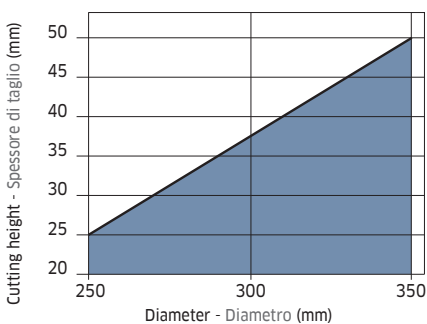

Maximum depth of cut based on the blade diameter.  
Altezza di taglio massima consentita in funzione del diametro della lama.

Solid wood  
Legno massiccio

Ultimate Eccellente	High Ottimo	Good Buono

Ripping of softwood  
Legno tenero lungo vena  
Ripping of hardwood  
Legno duro lungo vena

# LU1G

## HW - Saw blades to cut solid wood - rounded teeth on the side HW - Lame con denti bombati per il taglio di legni massicci

Saw blades suitable for ripping and crosscutting with fine cutting finish and without scratching, in order to achieve a perfectly smoothed surface.

**Machines:** Table saws.

**Features:** Straight tooth, rounded on the side, with positive cutting angle.  
**Material:** Softwood.

Lame per taglio lungo vena con ottima finitura e senza rigature, per ottenere una superficie perfettamente levigata.

**Macchine:** Seghe da banco.

**Caratteristiche:** Dentatura diritta con fianchi bombati con angolo di taglio positivo.

**Materiale:** Legni teneri.

**FT01:** 2/7/42 + 2/9/46,4 + 2/10/60

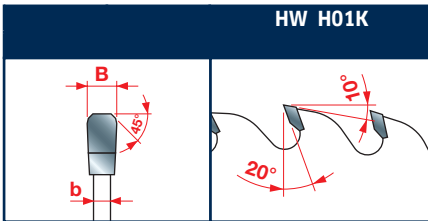

Tooth features - Caratteristiche del dente

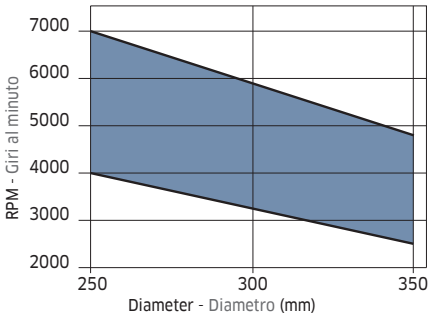

Minimum and maximum RPM based on the blade diameter.  
Fascia del N. giri minimo e massimo consigliati in funzione del diametro della lama.

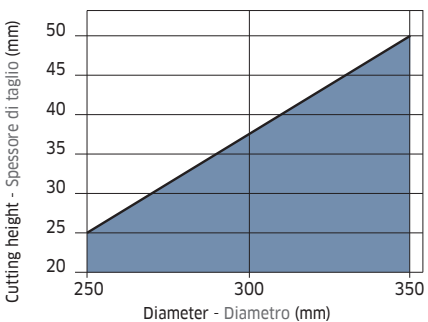

Maximum depth of cut based on the blade diameter.  
Altezza di taglio massima consentita in funzione del diametro della lama.

Solid wood  
Legno massiccio

	D	B	b	d	Z	NL	Code	SAP
	mm	mm	mm	mm		FT	Codice	SAP
	250	3,0	2,0	30	40	FT01	<b>LU1G 0100</b>	F03FS04646
	300	3,0	2,0	30	48	FT01	<b>LU1G 0200</b>	F03FS04647
	350	3,2	2,2	30	60	FT01	<b>LU1G 0300</b>	F03FS04648

**Comparison between the cut of a conventional saw blade and a saw blade equipped with teeth that is rounded on the side.**  
Confronto fra il taglio di una lama convenzionale e quello di una lama con denti a fianchi bombati.



Conventional saw blades  
Lame convenzionali



LU1G saw blades  
Lame LU1G

Ripping of softwood  
Legno tenero lungo vena

Ultimate	High	Good
Eccellente	Ottimo	Buono

# LU1H

## HW - Saw blades to cut solid wood - Thin kerf HW - Lama per il taglio di legni massicci - Sp. sottile

Saw blades suitable for ripping and crosscutting. The reduced cutting height makes workpiece feeding easier.

**Machines:** Table saws, portable machines.

**Features:** ATB 15° tooth with positive cutting angle.

**Material:** Good quality, soft and hard solid wood.

Lame per taglio lungo e trasverso vena. Lo spessore di taglio ridotto facilita l'avanzamento del pezzo da lavorare.

**Macchine:** Seghe da banco, macchine portatili.

**Caratteristiche:** Dentatura alterna a 15° con angolo di taglio positivo.

**Materiale:** Legni massicci pregiati teneri e duri.

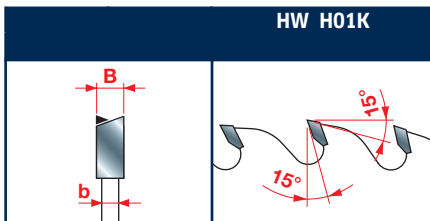
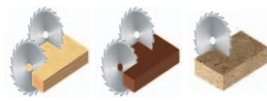

Tooth features - Caratteristiche del dente

**FT01:** 2/7/42 + 2/9/46,4 + 2/10/60

D mm	B mm	b mm	d mm	Z	NL FT	Code Codice	SAP SAP
180	1,5	1,0	30	40	2/7/42	LU1H 0100	F03FS04649
185	1,5	1,0	25,4	40		LU1H 0200	F03FS04650
200	1,5	1,0	30	40	2/7/42	LU1H 0300	F03FS07131
200	1,5	1,0	30	60	2/7/42	LU1H 0400	F03FS04651
205	1,5	1,0	25,4	40		LU1H 0500	F03FS04652
205	1,5	1,0	25,4	60		LU1H 0600	F03FS04653
250	2,5	1,6	30	48	FT01	LU1H 0700	F03FS04655
250	2,5	1,6	30	60	FT01	LU1H 0800	F03FS04657
250	2,8	2,0	30	30	2/10/60	LU1H 1500	F03FS04670
250	2,8	2,0	30	40	2/10/60	LU1H 1600	F03FS07127
300	2,8	2,0	30	36	FT01	LU1H 1400	F03FS04668
300	2,8	2,0	30	54	FT01	LU1H 0900	F03FS04659
300	2,8	2,0	35	54		LU1H 1000	F03FS04661
300	2,8	2,0	30	72	FT01	LU1H 1100	F03FS04663
350	3,0	2,2	30	60	FT01	LU1H 1200	F03FS04665
350	3,0	2,2	30	84	FT01	LU1H 1300	F03FS04667

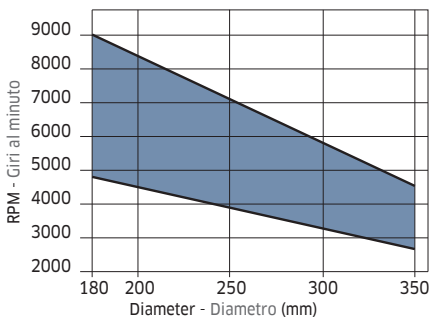

Minimum and maximum RPM based on the blade diameter.

Fascia del N. giri minimo e massimo consigliati in funzione del diametro della lama.

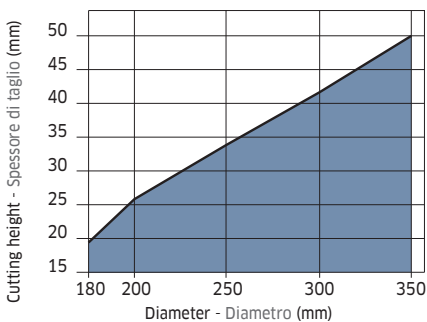

Maximum depth of cut based on the blade diameter. Altezza di taglio massima consentita in funzione del diametro della lama.

■ Solid wood  
■ Legno massiccio

Ripping and crosscutting of softwood  
Legno tenero lungo e trasverso vena  
Ripping and crosscutting of hardwood  
Legno duro lungo e trasverso vena  
Wood composites  
Composti di legno

Ultimate Eccellente	High Ottimo	Good Buono
	●	
	●	
		●

# LU1I

## HW - Saw blades to cut solid wood frames HW - Lame per il taglio di cornici in legno massiccio

Saw blades suitable for crosscutting. Without splintering frames and end trims of previously profiled items, where the items have to be coupled to perfectly match, even if they are covered with paint, chalk and other abrasive and fine materials.

**Machines:** Single or double-head miter saws.

**Features:** ATB 20° tooth with positive cutting angle.

**Material:** Soft and hard wood.

Lame per il taglio trasverso vena e senza scheggiature di cornici ed intestature di elementi già profilati, dove sia richiesto un perfetto assemblaggio degli elementi da accoppiare anche ricoperti con vernici, gesso ed altri materiali delicati e abrasivi.

**Macchine:** Troncatrici singole o doppie.

**Caratteristiche:** Dentatura alterna a 20° con angolo di taglio positivo.

**Materiale:** Legni teneri e duri.

**FT02:** 2/9/46,4 + 2/10/60

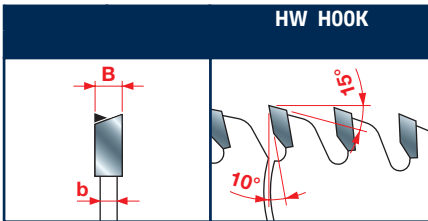
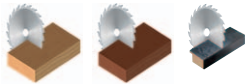
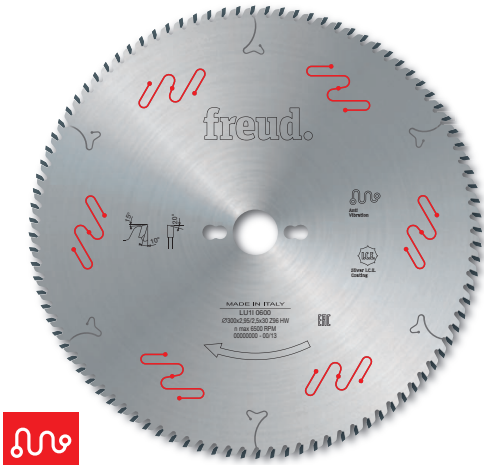

Tooth features - Caratteristiche del dente

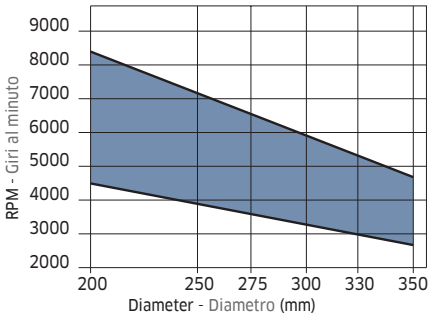

Minimum and maximum RPM based on the blade diameter.

Fascia del N. giri minimo e massimo consigliati in funzione del diametro della lama.

D	B	b	d	Z	NL	Code	SAP
mm	mm	mm	mm		FT	Code	SAP
200	2,95	2,5	30	64	2/7/42	LU1I 0100	F03FS04673
250	2,95	2,5	20	80	2/6/32	LU1I 0200	F03FS04675
250	2,95	2,5	30	80	FT02	LU1I 0300	F03FS04677
250	2,95	2,5	30	96	FT02	LU1I 0400	F03FS04679
275	2,95	2,5	20	84	2/6/32	LU1I 0500	F03FS04681
300	2,95	2,5	30	96	FT02	LU1I 0600	F03FS04682
300	2,95	2,5	30	112	FT02	LU1I 0700	F03FS04684
330	3,45	3,0	30	96	FT02	LU1I 0800	F03FS04686
350	3,45	3,0	30	108	FT02	LU1I 0900	F03FS04688

	Ultimate Eccellente	High Ottimo	Good Buono
Frames Cornici		●	

# LU1L

## HW - Saw blades to cut solid wood frames HW - Lama per il taglio di cornici in legno massiccio

Suitable for crosscutting. High-performance saw blade, with excellent cut and without splintering; finished and perfectly smooth surface, which is specifically recommended for frames' and profiles' end trims whose front-end cut keeps visible.

**Machines:** Single or double-head miter saws.

**Features:** Flat - ATB 10° tooth with axial 15° and positive cutting angle.

**Material:** Soft and hard wood.

Per il taglio trasverso vena. Lame di notevoli prestazioni, per un taglio perfetto e senza scheggiature, con superficie finita e perfettamente levigata. Consigliata in modo particolare per intestature di cornici e profilati, con taglio di testa che rimane in vista.

**Macchine:** Troncatrici singole o doppie.

**Caratteristiche:** Dente piano - alterno a 10° con assiale 15° e angolo di taglio positivo.

**Materiale:** Legni teneri e duri.

**FT01:** 2/7/42 + 2/9/46,4 + 2/10/60

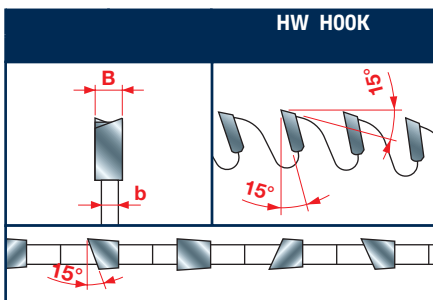

Tooth features - Caratteristiche del dente

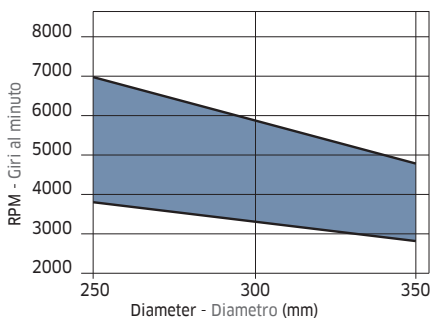

Minimum and maximum RPM based on the blade diameter.

Fascia del N. giri minimo e massimo consigliati in funzione del diametro della lama.

	D mm	B mm	b mm	d mm	Z	NL FT	Code Codice	SAP SAP
	250	3,0	2,2	30	100	FT01	<b>LU1L 0100</b>	F03FS04690
	250	3,0	2,2	30	120	FT01	<b>LU1L 0200</b>	F03FS04691
	255	3,0	2,2	25,4	100		<b>LU1L 0300</b>	F03FS04692
	255	3,0	2,2	25,4	120		<b>LU1L 0400</b>	F03FS04693
	300	3,0	2,2	30	100	FT01	<b>LU1L 0500</b>	F03FS04694
	300	3,0	2,2	30	120	FT01	<b>LU1L 0600</b>	F03FS04695
	305	3,0	2,2	25,4	100		<b>LU1L 0700</b>	F03FS04696
	305	3,0	2,2	25,4	120		<b>LU1L 0800</b>	F03FS04697
	305	3,0	2,2	30	100		<b>LU1L 1100</b>	F03FS06410
	350	3,0	2,2	30	120	FT01	<b>LU1L 0900</b>	F03FS04698
	355	3,0	2,2	25,4	120		<b>LU1L 1000</b>	F03FS04699

Frames  
Cornici

Ultimate Eccellente	High Ottimo	Good Buono
------------------------	----------------	---------------



# LU2A

## HW - Saw blades to cut wooden panels and composites HW - Lama per il taglio di pannelli di legno e composti

Saw blades suitable to ripping and crosscutting.

**Machines:** Circular saws, portable machines.

**Features:** ATB tooth with positive cutting angle.

**Material:** Soft and hard solid wood, unprocessed chipboard and plywood.

Lame per taglio lungo e trasverso vena.

**Macchine:** Seghe circolari, macchine portatili.

**Caratteristiche:** Dentatura alterna con angolo di taglio positivo.

**Materiale:** Legni massicci teneri e duri, pannelli stratificati, truciolari grezzi.

**FT01:** 2/7/42 + 2/9/46,4 + 2/10/60

**FT02:** 2/9/46,4 + 2/10/60

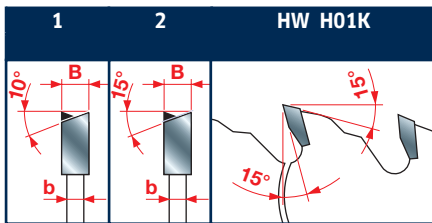

Tooth features - Caratteristiche del dente

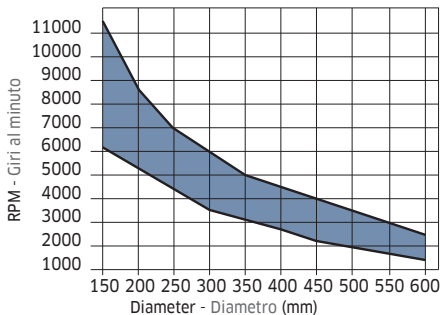

Minimum and maximum RPM based on the blade diameter.

Fascia del N. giri minimo e massimo consigliati in funzione del diametro della lama.

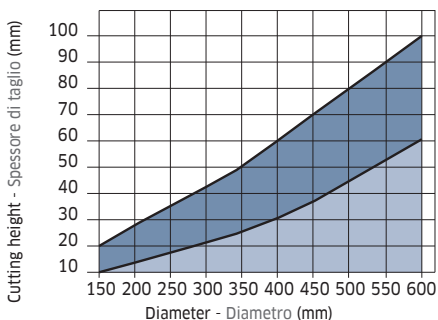

Maximum depth of rip and crosscut based on the blade diameter.

Altezza di taglio lungo e trasverso vena massima consentita in funzione del diametro della lama.

■ Solid wood (Legno massiccio) ■ Wood-base materials (Materiali su base legno)

### ATB 10° tooth (Fig. 1) - Dente alterno a 10° (Fig. 1)

D	B	b	d	Z	NL	Code	SAP
mm	mm	mm	mm		FT	Codice	SAP
150	3,2	2,2	30	24	2/7/42	LU2A 0100	F03FS04806
160	3,2	2,2	20	24	2/6/32	LU2A 0300	F03FS04809
180	3,2	2,2	30	30	2/7/42	LU2A 0500	F03FS04811
190	3,2	2,2	30	30	2/7/42	LU2A 0600	F03FS04813
200	3,2	2,2	30	34	2/7/42	LU2A 0800	F03FS04817
200	3,2	2,2	35	34		LU2A 0900	F03FS04819
210	3,2	2,2	30	34	2/7/42	LU2A 1100	F03FS04822
216	3,2	2,2	30	34		LU2A 1200	F03FS04823
220	3,2	2,2	30	34	2/7/42	LU2A 1300	F03FS04824
230	3,2	2,2	30	34	2/7/42	LU2A 1500	F03FS04827
250	3,2	2,2	30	40	FT01	LU2A 1700	F03FS04830
250	3,2	2,2	35	40		LU2A 1800	F03FS04832
300	3,2	2,2	30	48	FT01	LU2A 2100	F03FS04840
300	3,2	2,2	35	48		LU2A 2300	F03FS04843
315	3,2	2,2	30	48	FT01	LU2A 2400	F03FS04844
350	3,5	2,5	30	54	FT02	LU2A 2800	F03FS04849
350	3,5	2,5	35	54		LU2A 3000	F03FS04851
400	4,0	2,8	30	60	2/10/60	LU2A 3300	F03FS04856
400	4,0	2,8	35	60		LU2A 3400	F03FS04858
450	4,4	3,0	30	66	2/10/60	LU2A 3600	F03FS04862
500	4,4	3,2	30	72	2/10/80	LU2A 3800	F03FS04865
550	4,8	3,5	30	84	2/10/80	LU2A 3900	F03FS04867
600	5,4	4,0	30	96	2/10/80	LU2A 4000	F03FS04868
735	6,0	4,4	30	72	2/8,5/90	LU2A 4200	F03FS05908
760	6,2	4,5	30	72	2/8,5/90	LU2A 4300	F03FS05903

### ATB 15° tooth (Fig. 2) - Dente alterno a 15° (Fig. 2)

D	B	b	d	Z	NL	Code	SAP
mm	mm	mm	mm		FT	Codice	SAP
160	3,2	2,2	20	18	2/6/32	LU2A 0200	F03FS04808
180	3,2	2,2	20	24	2/6/32	LU2A 0400	F03FS04810
200	3,2	2,2	30	24	2/7/42	LU2A 0700	F03FS04814
210	3,2	2,2	30	24	2/7/42	LU2A 1000	F03FS04821
230	3,2	2,2	30	24	2/7/42	LU2A 1400	F03FS04826
250	3,2	2,2	30	30	FT01	LU2A 1600	F03FS04828
300	3,2	2,2	30	36	FT01	LU2A 1900	F03FS04834
350	3,5	2,5	30	42	FT02	LU2A 2500	F03FS04845
350	3,5	2,5	35	42		LU2A 2600	F03FS04847
400	4,0	2,8	30	48	2/10/60	LU2A 3100	F03FS04853
450	4,4	3,0	30	54	2/10/60	LU2A 3500	F03FS04860
500	4,4	3,2	30	60	2/10/80	LU2A 3700	F03FS04864

Ultimate Eccellente	High Ottimo	Good Buono
	●	
	●	
	●	

Ripping of solid wood  
Legno massiccio lungo vena  
Crosscutting of solid wood  
Legno massiccio trasverso vena  
Wood composites  
Composti di legno

# LU2B

## HW - Saw blades to cut wooden panels and composites HW - Lame per il taglio di pannelli di legno e composti

Saw blades suitable for ripping and crosscutting.

**Machines:** Circular saws, portable machines.

**Features:** ATB 15° tooth with positive cutting angle.

**Material:** Soft, hard and exotic solid wood, unprocessed chipboard and plywood.

Lame per taglio lungo e trasverso vena.

**Macchine:** Seghe circolari, macchine portatili.

**Caratteristiche:** Dentatura alterna a 15° con angolo di taglio positivo.

**Materiale:** Legni massicci teneri, duri ed esotici, pannelli in legno stratificati, truciolari grezzi.

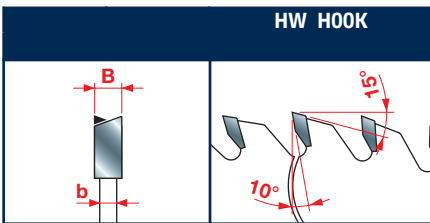
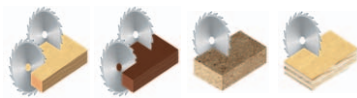

Tooth features - Caratteristiche del dente

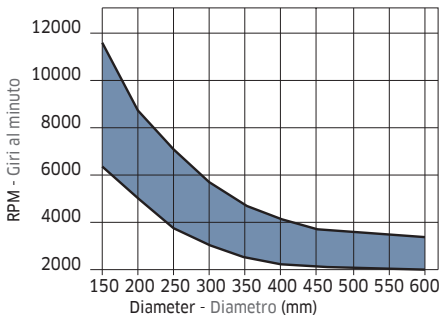

Minimum and maximum RPM based on the blade diameter.

Fascia del N. giri minimo e massimo consigliati in funzione del diametro della lama.

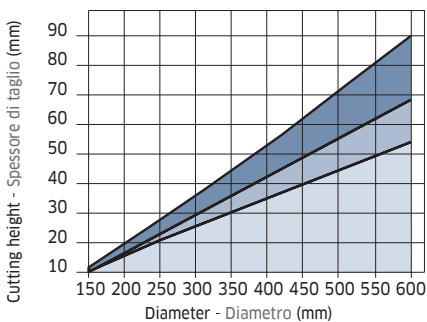

Maximum depth of rip and crosscut based on the blade diameter.

Altezza di taglio lungo e trasverso vena massima consentita in funzione del diametro della lama.

Solid wood  
 Wood-base materials  
 Plywood  
 Legno massiccio    Materiali su base legno    Multistrato

**FT01:** 2/7/42 + 2/9/46,4 + 2/10/60

**FT02:** 2/9/46,4 + 2/10/60

D mm	B mm	b mm	d mm	Z	NL FT	Code Codice	SAP SAP
150	3,2	2,2	30	36	2/7/42	LU2B 0100	F03FS04869
180	3,2	2,2	30	42	2/7/42	LU2B 0200	F03FS04871
200	3,2	2,2	30	48	2/7/42	LU2B 0300	F03FS04873
216	3,2	2,2	30	48		LU2B 0400	F03FS04876
250	3,2	2,2	30	48	FT01	LU2B 0500	F03FS04877
250	3,2	2,2	30	60	FT01	LU2B 0700	F03FS04880
250	3,2	2,2	35	60		LU2B 0800	F03FS04882
300	3,2	2,2	30	60	FT01	LU2B 0900	F03FS04884
300	3,2	2,2	30	72	FT01	LU2B 1100	F03FS04887
300	3,2	2,2	35	72		LU2B 1200	F03FS04889
315	3,2	2,2	30	72	FT01	LU2B 1300	F03FS04891
350	3,5	2,5	30	72	FT02	LU2B 1400	F03FS04893
350	3,5	2,5	30	84	FT02	LU2B 1600	F03FS04895
350	3,5	2,5	35	84		LU2B 2400	F03FS04905
400	4,0	2,8	30	96	2/10/60	LU2B 1900	F03FS04897
450	4,4	3,0	30	96	2/10/60	LU2B 2000	F03FS04899
500	4,4	3,2	30	108	2/10/80	LU2B 2100	F03FS04901
550	4,8	3,5	30	120	2/10/80	LU2B 2200	F03FS04903
600	5,4	4,0	30	132	2/10/80	LU2B 2300	F03FS04904

	Ultimate Eccellente	High Ottimo	Good Buono
Ripping of solid wood Legno massiccio lungo vena		●	
Crosscutting of solid wood Legno massiccio trasverso vena	●		
Wood composites Composti di legno		●	

## HW - Saw blades to cut wooden panels and composites HW - Lame per il taglio di pannelli di legno e composti

Saw blades suitable for crosscutting.

**Machines:** Circular saws, portable machines.

**Features:** ATB 15° tooth with positive cutting angle.

**Material:** Soft, hard and exotic solid wood, chipboard, thermoplastic-wood composites, MDF laminated on one side.

Lame per taglio trasverso vena.

**Macchine:** Seghe circolari, macchine portatili.

**Caratteristiche:** Dentatura alterna a 15° con angolo di taglio positivo.

**Materiale:** Legni massicci teneri, duri, esotici, truciolari, termoplastici, MDF laminati su un solo lato.

**FT01:** 2/7/42 + 2/9/46,4 + 2/10/60

**FT02:** 2/9/46,4 + 2/10/60

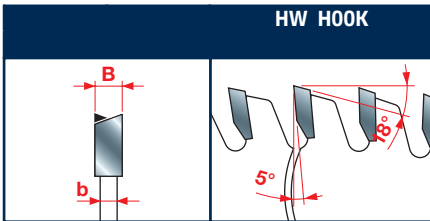
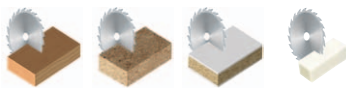
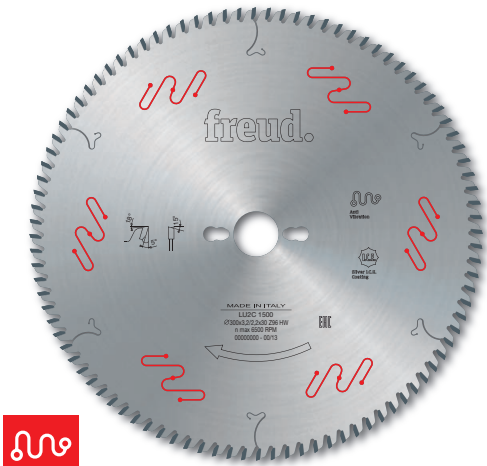

Tooth features - Caratteristiche del dente

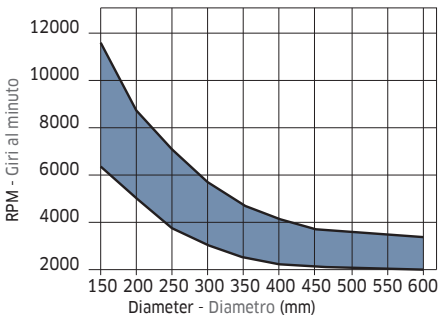

Minimum and maximum RPM based on the blade diameter.

Fascia del N. giri minimo e massimo consigliati in funzione del diametro della lama.

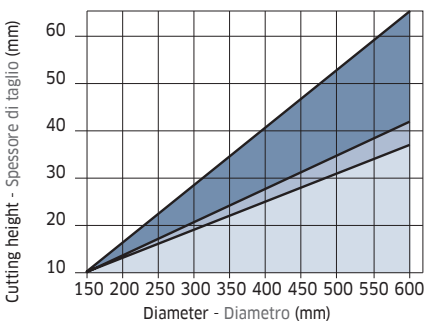

Maximum depth of crosscut based on the blade diameter.

Altezza di taglio trasverso vena massima consentita in funzione del diametro della lama.

Solid wood  
 Legno massiccio

Wood-base materials  
 Materiali su base legno

Plywood  
 Multistrato

D	B	b	d	Z	NL	Code	SAP
mm	mm	mm	mm		FT	Codice	SAP
150	3,2	2,2	30	48	2/7/42	LU2C 0100	F03FS04908
160	3,2	2,2	20	48	2/6/32	LU2C 0200	F03FS04910
180	3,2	2,2	20	56	2/6/32	LU2C 0300	F03FS04911
180	3,2	2,2	30	56	2/7/42	LU2C 0400	F03FS04912
190	3,2	2,2	30	56	2/7/42	LU2C 0500	F03FS04914
200	3,2	2,2	30	64	2/7/42	LU2C 0600	F03FS04915
210	3,2	2,2	30	64	2/7/42	LU2C 0700	F03FS04917
216	3,2	2,2	30	64	2/7/42	LU2C 0800	F03FS04918
220	3,2	2,2	30	64	2/7/42	LU2C 0900	F03FS04919
230	3,2	2,2	30	64	2/7/42	LU2C 1000	F03FS04921
250	3,2	2,2	30	80	FT01	LU2C 1200	F03FS04922
250	3,2	2,2	30	100	FT01	LU2C 1300	F03FS04924
300	3,2	2,2	30	96	FT01	LU2C 1500	F03FS04927
300	3,2	2,2	35	96		LU2C 1600	F03FS04930
300	3,2	2,2	30	120	FT01	LU2C 1700	F03FS04932
330	3,2	2,2	20	96	2/6/32	LU2C 1800	F03FS04934
350	3,5	2,5	30	108	FT02	LU2C 2000	F03FS04936
400	3,8	2,8	30	120	2/10/60	LU2C 2100	F03FS04938
450	4,4	3,0	30	132	FT02	LU2C 2200	F03FS04939
500	4,4	3,2	30	144	2/10/80	LU2C 2300	F03FS04940
550	4,8	3,5	30	156	2/10/80	LU2C 2400	F03FS04942
600	5,4	4,0	30	168	2/10/80	LU2C 2500	F03FS04943

	Ultimate Eccellente	High Ottimo	Good Buono
Crosscutting of solid wood Legno massiccio trasverso vena	●		
Wood composites Composti di legno	●		
Plastic materials Materiali plastici		●	

## HW - Saw blades to cut wooden panels and composites - Thin kerf

## HW - Lame per il taglio di pannelli di legno e composti - Sp. sottile

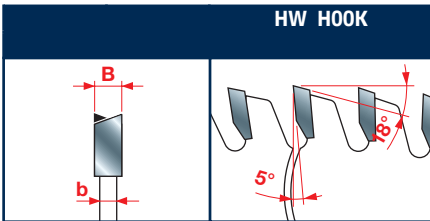
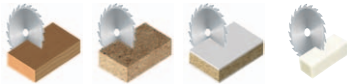

Tooth features - Caratteristiche del dente

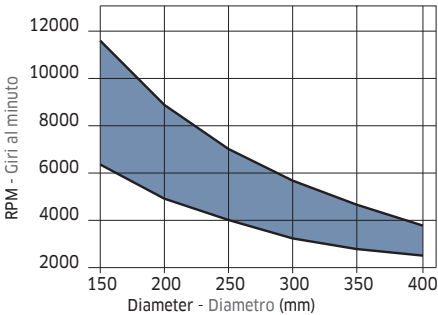

Minimum and maximum RPM based on the blade diameter. Fascia del N. giri minimo e massimo consigliati in funzione del diametro della lama.

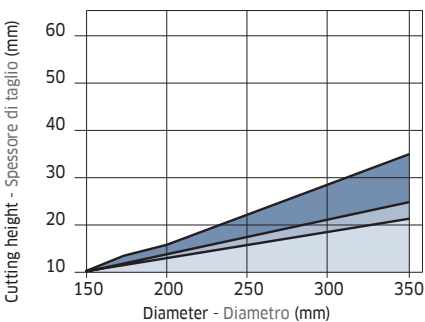

Maximum depth of rip and crosscut based on the blade diameter. Altezza di taglio lungo e trasverso vena massima consentita in funzione del diametro della lama.

- Solid wood  
Legno massiccio
- Wood-base materials  
Materiali su base legno
- Plywood  
Multistrato

Saw blades suitable for crosscutting. The reduced cutting height makes work-piece feeding easier.

**Machines:** Circular saws, portable machines.

**Features:** ATB 15° tooth with positive cutting angle.

**Material:** Soft, hard and exotic solid wood, chipboard, thermoplastic-wood composites, MDF laminated on one side.

Lame per taglio trasverso vena. Lo spessore di taglio ridotto facilita l'avanzamento del pezzo da lavorare.

**Macchine:** Seghe circolari, macchine portatili.

**Caratteristiche:** Dentatura alterna a 15° con angolo di taglio positivo.

**Materiale:** Legni massicci teneri, duri, esotici, truciolare, termoplastici, MDF laminati su un solo lato.

**FT01:** 2/7/42 + 2/9/46,4 + 2/10/60

D mm	B mm	b mm	d mm	Z	NL FT	Code Codice	SAP SAP
150	2,0	1,4	30	48	2/7/42	LU2D 0100	F03FS04944
180	2,0	1,4	30	56	2/7/42	LU2D 0200	F03FS04948
180	2,0	1,4	40	56		LU2D 0300	F03FS04950
200	2,2	1,6	30	64	2/7/42	LU2D 0400	F03FS04952
250	2,5	1,8	20	80	2/6/32	LU2D 0500	F03FS04954
250	2,5	1,8	30	80	FT01	LU2D 0700	F03FS04957
300	2,7	1,8	30	96	FT01	LU2D 0900	F03FS04959
350	3,0	2,2	30	108	FT01	LU2D 1100	F03FS04963

	Ultimate Eccellente	High Ottimo	Good Buono
Crosscutting of solid wood Legno massiccio trasverso vena	●		
Wood composites Composti di legno	●		
Plastic materials Materiali plastici		●	

## HW - Saw blades to cut exotic abrasive wood and panels HW - Lame per il taglio di pannelli e legni esotici abrasivi

Saw blades suitable for crosscutting.

**Machines:** Circular saws, panel-sizing machines.

**Features:** ATB 15° tooth with positive cutting angle.

**Material:** Good quality soft and hard wood, up to 50 mm chipboard, MDF laminated on one side, up to 30 mm.

Lame per taglio trasverso vena.

**Macchine:** Seghe circolari, sezionatrici.

**Caratteristiche:** Dentatura alterna a 15° con angolo di taglio positivo.

**Materiale:** Legni teneri e duri pregiati fino a 50 mm, truciolare, MDF laminati su un solo lato, fino a 30 mm.

**FT01:** 2/7/42 + 2/9/46,4 + 2/10/60

**FT02:** 2/9/46,4 + 2/10/60

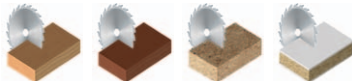

	D mm	B mm	b mm	d mm	Z	NL FT	Code Codice	SAP SAP
	300	3,2	2,2	30	60	FT01	LU2E 0200	F03FS04965
	300	3,2	2,2	30	72	FT01	LU2E 0400	F03FS04967
	350	3,5	2,5	30	72	FT02	LU2E 0500	F03FS04970

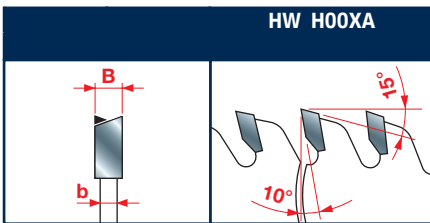

Tooth features - Caratteristiche del dente

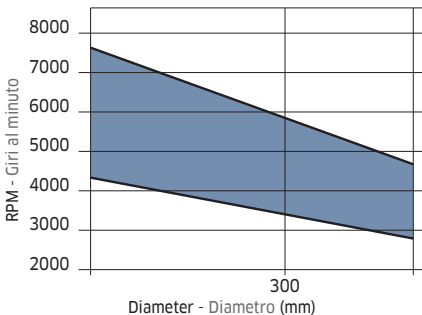

Minimum and maximum RPM based on the blade diameter.

Fascia del N. giri minimo e massimo consigliati in funzione del diametro della lama.

Ultimate Eccellente	High Ottimo	Good Buono
	●	
●		

Crosscutting of soft and hardwood  
Legno tenero e duro trasverso vena  
Wood composites  
Composti di legno

## HW - Saw blades to cut wooden panels, composites and plastic materials

### HW - Lame per il taglio di pannelli di legno, composti e materiali plastici

To size bilaminated panels without the employment of the scoring saw blade, with good finishing and long cutting life.

**Machines:** Circular saws, horizontal panel sizing machines, portable machines.

**Features:** ATB 10° tooth with negative cutting angle.

**Material:** Bilaminated panels with abrasive and hard coatings.

Per la sezionatura in singolo di pannelli bilaminati, senza l'ausilio della lama incisore, con buona finitura e lunga durata di taglio.

**Macchine:** Seghe circolari, sezionatrici orizzontali, macchine portatili.

**Caratteristiche:** Dentatura alterna a 10° con angolo di taglio negativo.

**Materiale:** Pannelli bilaminati con rivestimenti duri e abrasivi.

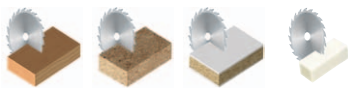

D mm	B mm	b mm	d mm	Z	Code Codice	SAP SAP
216	2,8	2,0	30	24	LU2F 0100	F03FS06304
216	2,8	2,0	30	48	LU2F 0200	F03FS04971
216	2,8	2,0	30	60	LU2F 0300	F03FS04972
250	2,8	2,0	30	48	LU2F 0400	F03FS04973
250	2,8	2,0	30	60	LU2F 0500	F03FS04974

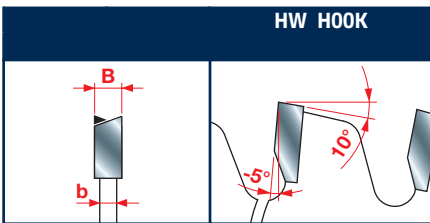

Tooth features - Caratteristiche del dente

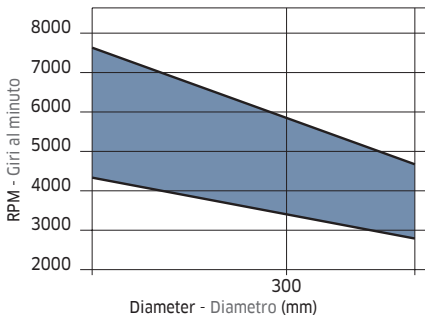

Minimum and maximum RPM based on the blade diameter.

Fascia del N. giri minimo e massimo consigliati in funzione del diametro della lama.

	Ultimate Eccellente	High Ottimo	Good Buono
Crosscutting of solid wood Legno massiccio trasverso vena	●		
Wood composites Composti di legno	●		
Plastic materials Materiali plastici		●	

## HW - Saw blades to cut bilaminated panels HW - Lame per il taglio di pannelli bilaminati

To size bilaminated panels, with perfect finishing on both sides without the employment of the scoring saw blade.

**Machines:** Circular vertical saws, panel-sizing machines, portable machines.

**Features:** ATB 38° tooth, with variable cutting angle according to the diameter.

**Material:** Bilaminated panels with extremely fine coatings, veneered panels.

Per la sezionatura in singolo di pannelli bilaminati, con perfetta finitura su ambo i lati senza l'ausilio della lama incisore.

**Macchine:** Seghe circolari, sezionatrici verticali.

**Caratteristiche:** Dentatura alterna a 38°, con angolo di taglio variabile a seconda del diametro.

**Materiale:** Pannelli bilaminati con rivestimenti particolarmente delicati, impiallacciati.

**FT01:** 2/7/42 + 2/9/46,4 + 2/10/60

**FT02:** 2/9/46,4 + 2/10/60

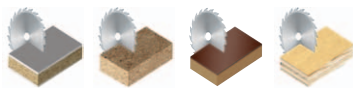
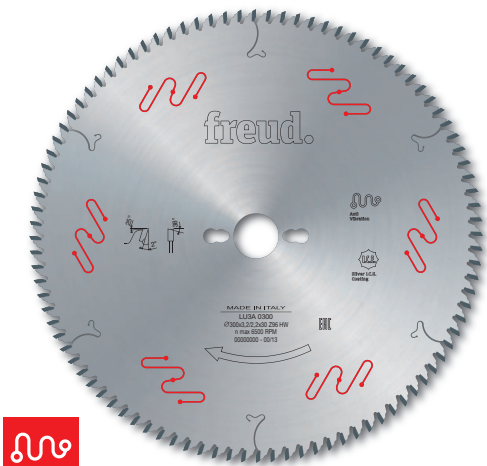

	D mm	B mm	b mm	d mm	Z	$\alpha$	NL FT	Code Codice	SAP SAP
	220	3,2	2,2	30	64	-5°	2/7/42	LU3A 0100	F03FS05059
	250	3,2	2,2	30	80	-2°	FT01	LU3A 0200	F03FS05061
	300	3,2	2,2	25,4	96	2°		LU3A 0600	F03FS05807
	300	3,2	2,2	30	96	2°	FT01	LU3A 0300	F03FS05064
	350	3,5	2,5	30	108	5°	FT02	LU3A 0400	F03FS05066

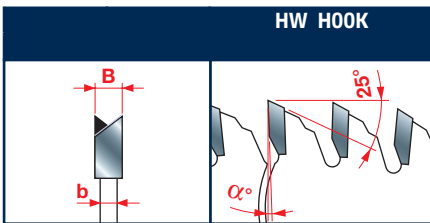

Tooth features - Caratteristiche del dente

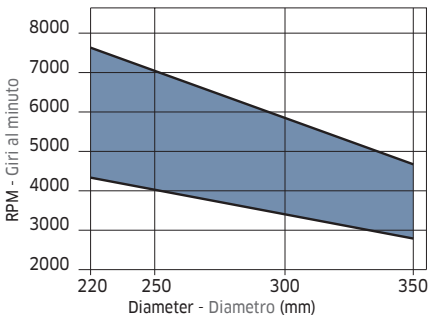

Minimum and maximum RPM based on the blade diameter.  
Fascia del N. giri minimo e massimo consigliati in funzione del diametro della lama.

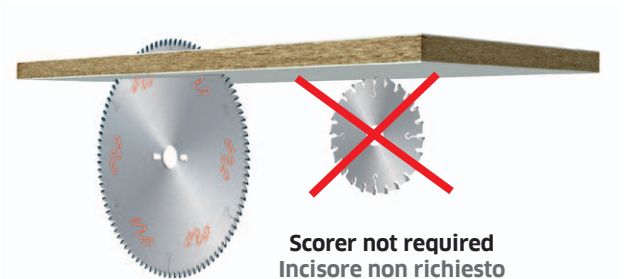

Scorer not required  
Incisore non richiesto

	Ultimate Eccellente	High Ottimo	Good Buono
Wood composites Composti di legno	●		
Laminates Laminati	●		

### Working with spindle under the working plane Lavorazione con albero sotto il piano di lavoro

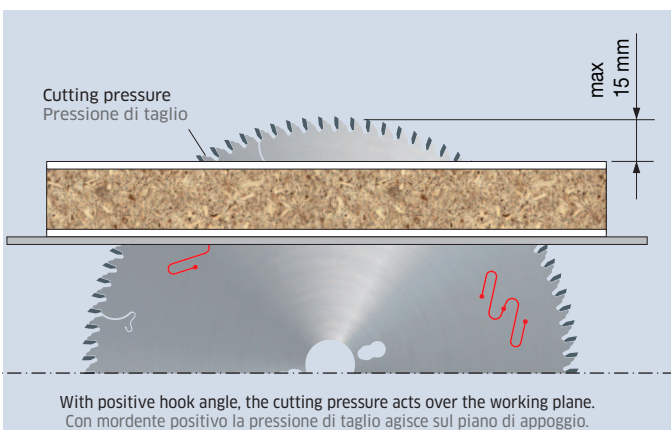

With positive hook angle, the cutting pressure acts over the working plane.  
Con mordente positivo la pressione di taglio agisce sul piano di appoggio.

### Working with spindle over the working plane Lavorazione con albero sopra il piano di lavoro

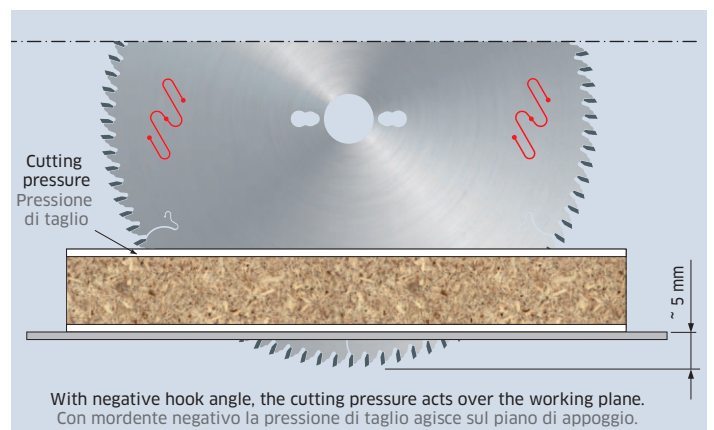

With negative hook angle, the cutting pressure acts over the working plane.  
Con mordente negativo la pressione di taglio agisce sul piano di appoggio.

# LU3B

## HW - Saw blades to cut bilaminated panels HW - Lame per il taglio di pannelli bilaminati

To size bilaminated panels without the employment of the scoring saw blade, with good finishing and long cutting life.

**Machines:** Circular saws, vertical machines without the scoring saw blade.

**Features:** Conical - triple chip tooth with concave face and positive cutting angle.

**Material:** Bilaminated panels with abrasive and hard coatings.

Per la sezionatura in singolo di pannelli bilaminati, senza l'ausilio della lama incisore, con buona finitura e lunga durata di taglio.

**Macchine:** Seghe circolari, macchine verticali senza incisore.

**Caratteristiche:** Dentatura conica-trapezoidale con petto concavo e angolo di taglio positivo.

**Materiale:** Pannelli bilaminati con rivestimenti duri e abrasivi.

**FT01:** 2/7/42 + 2/9/46,4 + 2/10/60

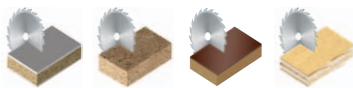

D mm	B mm	b mm	d mm	Z	NL FT	Code Codice	SAP SAP
220	3,2	2,2	30	42	2/7/42	<b>LU3B 0100</b>	F03FS05069
250	3,2	2,2	30	48	FT01	<b>LU3B 0200</b>	F03FS05071
303	3,2	2,2	30	60	FT01	<b>LU3B 0300</b>	F03FS05073
350	3,2	2,2	30	72	FT01	<b>LU3B 0400</b>	F03FS05075

D mm	B mm	b mm	d mm	Z	NL FT	Code Codice	SAP SAP
303	3,2	2,2	30	60	FT01	<b>LU3B 1300</b>	F03FS06478

**Features:** Flat - triple chip tooth with concave face and positive cutting angle.

**Caratteristiche:** Dentatura piano-trapezoidale con petto concavo e angolo di taglio positivo.

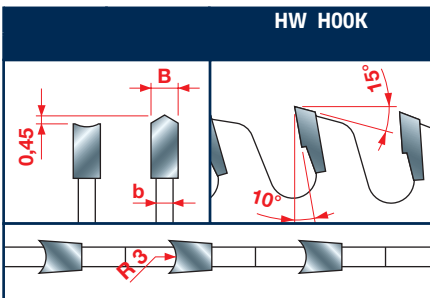

Tooth features - Caratteristiche del dente

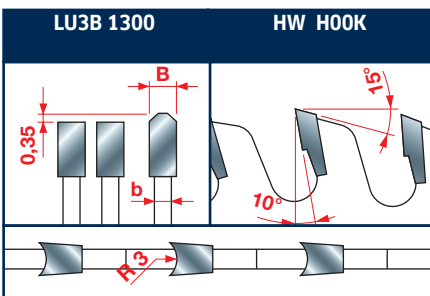

Tooth features - Caratteristiche del dente

	Ultimate Eccellente	High Ottimo	Good Buono
Wood composites Composti di legno	●		
Laminates Laminati	●		

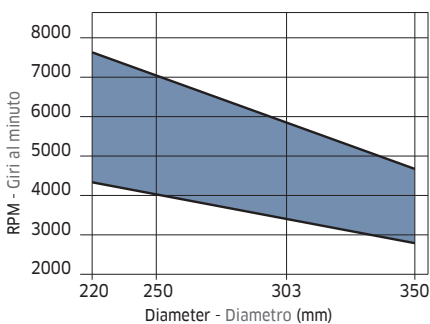

Minimum and maximum RPM based on the blade diameter.

Fascia del N. giri minimo e massimo consigliati in funzione del diametro della lama.

### Working with spindle over the working plane Lavorazione con albero sopra il piano di lavoro

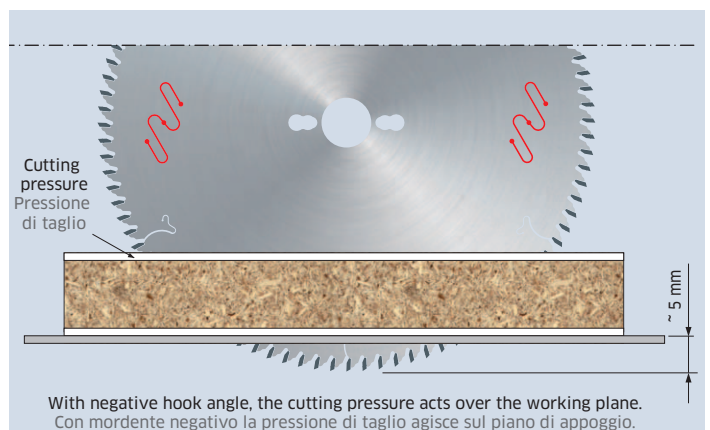

With negative hook angle, the cutting pressure acts over the working plane.  
Con mordente negativo la pressione di taglio agisce sul piano di appoggio.

## HW - Saw blades to cut bilaminated panels HW - Lame per il taglio di pannelli bilaminati

To size bilaminated panels without the employment of the scoring saw blade, with good finishing and long cutting life.

**Machines:** Circular saws, horizontal panel sizing machines.

**Features:** Conical - triple chip tooth with concave face and negative cutting angle.

**Material:** Bilaminated panels with abrasive and hard coatings.

Per la sezionatura in singolo di pannelli bilaminati, senza l'ausilio della lama incisore, con buona finitura e lunga durata di taglio.

**Macchine:** Seghe circolari, sezionatrici orizzontali.

**Caratteristiche:** Dentatura conica-trapezoidale con petto concavo e angolo di taglio negativo.

**Materiale:** Pannelli bilaminati con rivestimenti duri e abrasivi.

**FT01:** 2/7/42 + 2/9/46,4 + 2/10/60

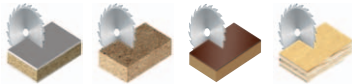

	D mm	B mm	b mm	d mm	Z	NL FT	Code Codice	SAP SAP
	220	3,2	2,2	30	42	2/7/42	<b>LU3C 0100</b>	F03FS05076
	250	3,2	2,2	30	48	FT01	<b>LU3C 0200</b>	F03FS05077
	303	3,2	2,2	30	60	FT01	<b>LU3C 0300</b>	F03FS05078
	350	3,2	2,2	30	72	FT01	<b>LU3C 0400</b>	F03FS05080

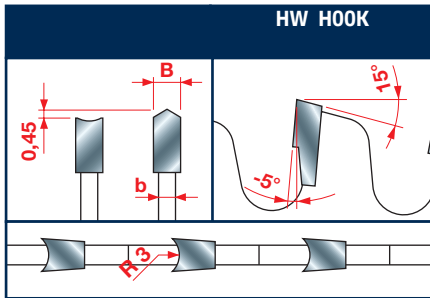

Tooth features - Caratteristiche del dente

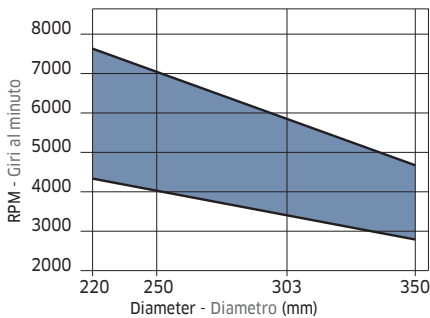

Minimum and maximum RPM based on the blade diameter.  
Fascia del N. giri minimo e massimo consigliati in funzione del diametro della lama.

### Working with spindle over the working plane Lavorazione con albero sopra il piano di lavoro

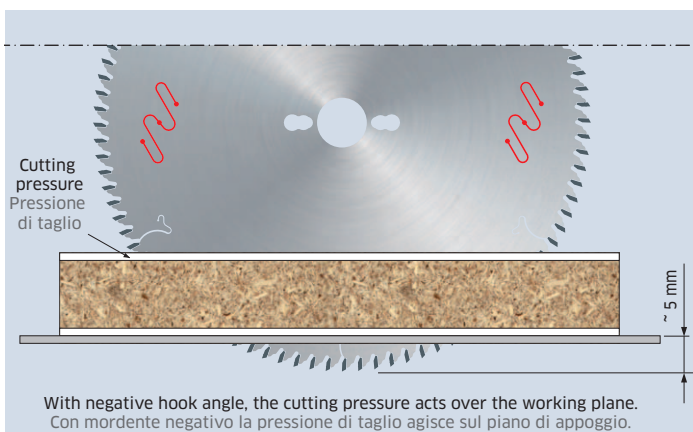

With negative hook angle, the cutting pressure acts over the working plane.  
Con mordente negativo la pressione di taglio agisce sul piano di appoggio.

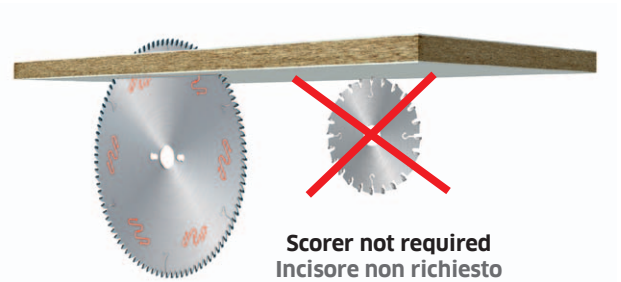

	Ultimate Eccellente	High Ottimo	Good Buono
Wood composites Composti di legno	●		
Laminates Laminati	●		

# LU3D

## HW - Saw blades to cut bilaminated panels HW - Lama per il taglio di pannelli bilaminati

To size bilaminated panels with the employment of the scoring saw blade, in detail melamine-coated panels, with good finishing and long cutting life.

**Machines:** Circular saws, horizontal panel sizing machines.

**Features:** Flat-triple chip tooth with positive cutting angle.

**Material:** Bilaminated panels.

Per la sezionatura con l'ausilio della lama incisore di pannelli bilaminati, in particolare quelli rivestiti in melaminico, con buona finitura e lunga durata di taglio.

**Macchine:** Seghe circolari, sezionatrici orizzontali.

**Caratteristiche:** Dente piano-trapezoidale con angolo di taglio positivo.

**Materiale:** Pannelli bilaminati.

**FT01:** 2/7/42 + 2/9/46,4 + 2/10/60

**FT02:** 2/9/46,4 + 2/10/60

**Hook angle 5° for cutting heights up to 30 mm**

**Mordente 5° per spessori di taglio fino a 30 mm**

D	B	b	d	Z	$\alpha$	NL	Code	SAP
mm	mm	mm	mm			FT	Codice	SAP
200	3,2	2,2	30	64	5°	2/7/42	<b>LU3D 0100</b>	F03FS05081
220	3,2	2,2	30	64	5°	2/7/42	<b>LU3D 0200</b>	F03FS05083
250	3,2	2,2	30	80	5°	FT01	<b>LU3D 0400</b>	F03FS05088
300	3,2	2,2	30	96	5°	FT01	<b>LU3D 0600</b>	F03FS05093
300	3,2	2,2	35	96	5°		<b>LU3D 0700</b>	F03FS05096
350	3,5	2,5	30	108	5°	FT02	<b>LU3D 0900</b>	F03FS05098

**Hook angle 10° for cutting heights up to 40 mm**

**Mordente 10° per spessori di taglio fino a 40 mm**

D	B	b	d	Z	$\alpha$	NL	Code	SAP
mm	mm	mm	mm			FT	Codice	SAP
250	3,2	2,2	30	60	10°	FT01	<b>LU3D 1100</b>	F03FS05100
300	3,2	2,2	30	72	10°	FT01	<b>LU3D 2100</b>	F03FS05810
300	3,2	2,2	30	84	10°	FT01	<b>LU3D 1300</b>	F03FS05101
300	3,2	2,2	30	96	10°	FT01	<b>LU3D 1500</b>	F03FS05104
350	3,5	2,5	30	72	10°	FT02	<b>LU3D 2000</b>	F03FS05108
350	3,5	2,5	30	108	10°	FT02	<b>LU3D 1700</b>	F03FS05105

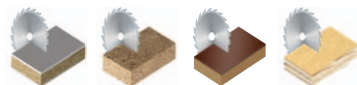

### HW H00XA

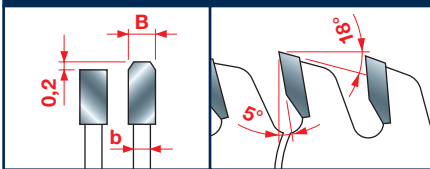

Tooth features - Caratteristiche del dente

### HW H00XA

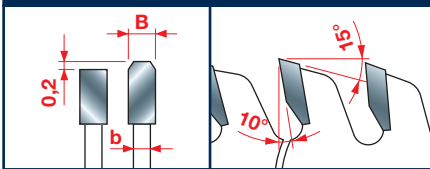

Tooth features - Caratteristiche del dente

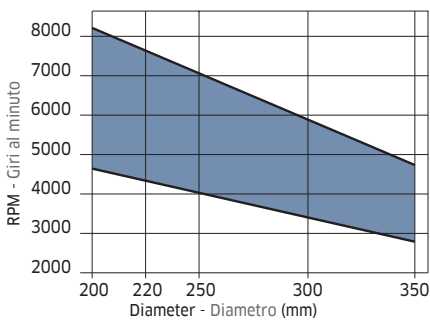

Minimum and maximum RPM based on the blade diameter.

Fascia del N. giri minimo e massimo consigliati in funzione del diametro della lama.

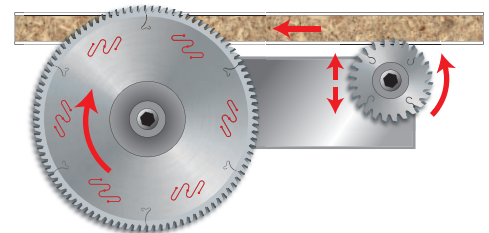

Wood composites  
Composti di legno  
Laminates  
Laminati

Ultimate Eccellente	High Ottimo	Good Buono
●	●	●

## HW - Saw blades to cut bilaminated panels HW - Lame per il taglio di pannelli bilaminati

To size bilaminated panels without the employment of the scoring saw blade, up to 40 mm thick. In detail, it is suitable to work melamine-coated panels.  
**Machines:** Circular saws, horizontal panel sizing machines, vertical panel sizing machines.

**Features:** Flat-triple chip tooth with negative cutting angle.

**Material:** Bilaminated panels.

Per la sezionatura senza l'ausilio della lama incisore di pannelli bilaminati singoli o in pacco fino ad uno spessore di 40 mm. Particolarmente indicata nella lavorazione di pannelli rivestiti in melaminico.

**Macchine:** Seghe circolari, sezionatrici orizzontali, sezionatrici verticali.

**Caratteristiche:** Dente piano-trapezoidale con angolo di taglio negativo.

**Materiale:** Pannelli bilaminati.

**FT01:** 2/7/42 + 2/9/46,4 + 2/10/60

**FT02:** 2/9/46,4 + 2/10/60

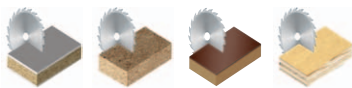
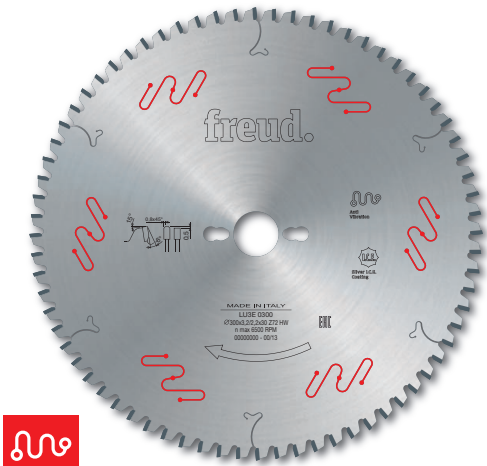

	D mm	B mm	b mm	d mm	Z	NL FT	Code Codice	SAP SAP
	220	3,2	2,2	30	56	2/7/42	LU3E 0100	F03FS05109
	250	3,2	2,2	30	60	FT01	LU3E 0200	F03FS05111
	300	3,2	2,2	30	72	FT01	LU3E 0300	F03FS05113
	350	3,5	2,5	30	84	FT02	LU3E 0400	F03FS05115

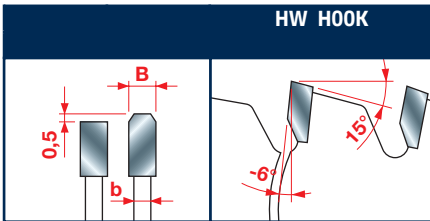

Tooth features - Caratteristiche del dente

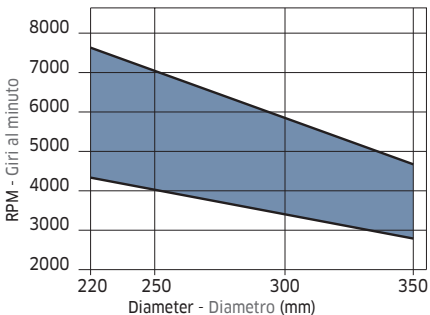

Minimum and maximum RPM based on the blade diameter.  
Fascia del N. giri minimo e massimo consigliati in funzione del diametro della lama.



### Working with spindle over the working plane Lavorazione con albero sopra il piano di lavoro

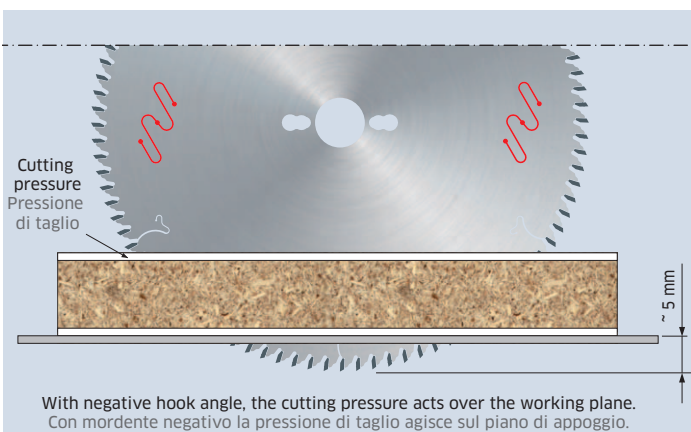

With negative hook angle, the cutting pressure acts over the working plane.  
Con mordente negativo la pressione di taglio agisce sul piano di appoggio.

	Ultimate Eccellente	High Ottimo	Good Buono
Wood composites Composti di legno		●	
Laminates Laminati	●		

# LU3F

## HW - Saw blades to cut bilaminated panels HW - Lama per il taglio di pannelli bilaminati

To size bilaminated panels without the employment of the scoring saw blade. In detail, it is suitable to work melamine-coated panels and plastic materials.  
**Machines:** Circular saws, horizontal panel sizing machines, vertical panel sizing machines.

**Features:** Flat-triple chip tooth with negative cutting angle.

**Material:** Bilaminated panels, plastic materials.

Per la sezionatura senza l'ausilio della lama incisore di pannelli bilaminati. Particolarmente indicata nella lavorazione di pannelli rivestiti in melaminico e di materiali plastici.

**Macchine:** Seghe circolari, sezionatrici orizzontali, sezionatrici verticali.

**Caratteristiche:** Dente piano-trapezoidale con angolo di taglio negativo.

**Materiale:** Pannelli bilaminati, materiali plastici.

**FT01:** 2/7/42 + 2/9/46,4 + 2/10/60

**FT02:** 2/9/46,4 + 2/10/60

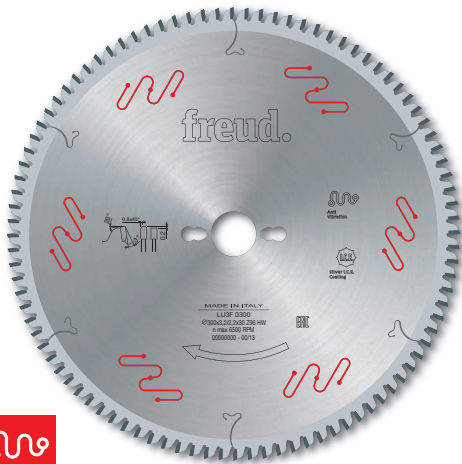

	D mm	B mm	b mm	d mm	Z	NL FT	Code Codice	SAP SAP
	220	3,2	2,2	30	64	2/7/42	LU3F 0100	F03FS05117
	250	3,2	2,2	30	80	FT01	LU3F 0200	F03FS05119
	300	3,2	2,2	30	96	FT01	LU3F 0300	F03FS05121
	350	3,5	2,5	30	108	FT02	LU3F 0400	F03FS05124

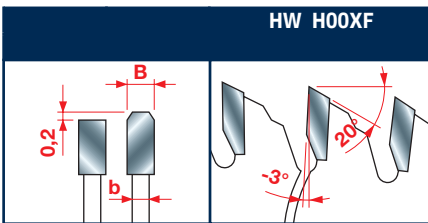

Tooth features - Caratteristiche del dente

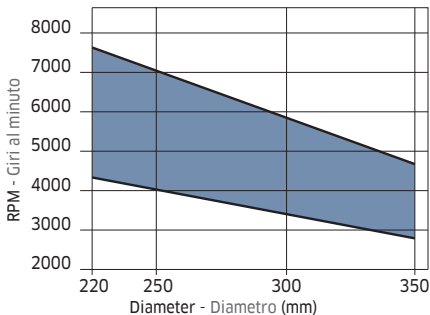

Minimum and maximum RPM based on the blade diameter.

Fascia del N. giri minimo e massimo consigliati in funzione del diametro della lama.

### Working with spindle over the working plane Lavorazione con albero sopra il piano di lavoro

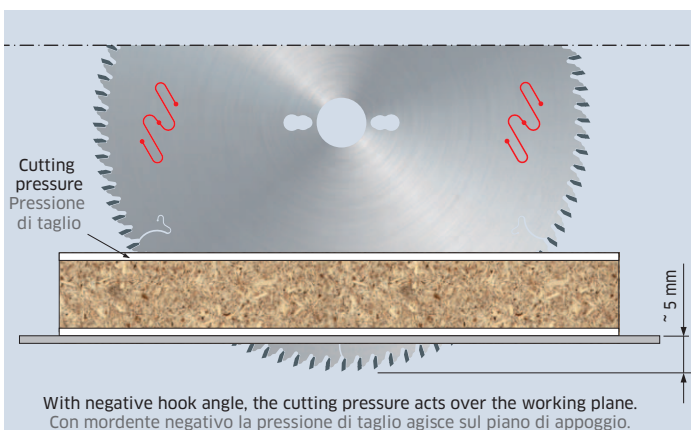

	Ultimate Eccellente	High Ottimo	Good Buono
Wood composites Composti di legno	●		
Laminates Laminati	●		

## HW - Saw blades to cut solid wood HW - Lame per il taglio di legni massicci

Saw blades suitable for ripping.

**Machines:** Table saws, multiripping machines.

**Features:** ATB 10° tooth with positive cutting angle.

**Material:** Soft and hard solid wood, also with loose knots.

Lame per taglio lungo vena.

**Macchine:** Seghe da banco, multilame.

**Caratteristiche:** Dentatura alterna a 10° con angolo di taglio positivo.

**Materiale:** Legni teneri e duri massicci anche con nodi cascanti.

**FT01:** 2/7/42 + 2/9/46,4 + 2/10/60

**FT02:** 2/9/46,4 + 2/10/60



D	B	b	d	Z	NL	Code	SAP
mm	mm	mm	mm		FT	Codice	SAP
250	3,2	2,2	30	22	FT01	<b>LG1C 0100</b>	F03FS07559
300	3,2	2,2	30	26	FT01	<b>LG1C 0400</b>	F03FS07560
350	3,5	2,5	30	30	FT02	<b>LG1C 1000</b>	F03FS07561

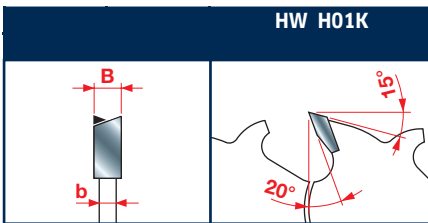
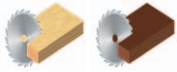

Tooth features - Caratteristiche del dente

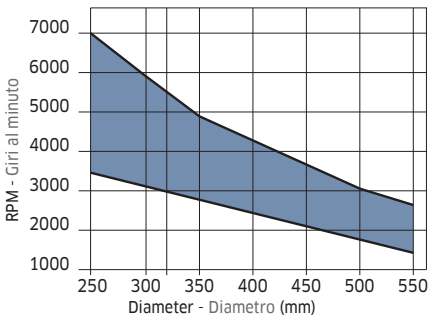

Minimum and maximum RPM based on the blade diameter.  
Fascia del N. giri minimo e massimo consigliati in funzione del diametro della lama.

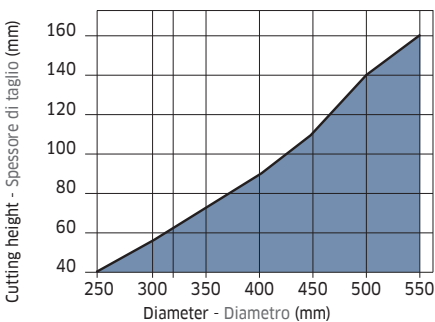

Maximum depth of cut based on the blade diameter.  
Altezza di taglio massima consentita in funzione del diametro della lama.

■ Solid wood  
■ Legno massiccio

Ultimate	High	Good
Eccellente	Ottimo	Buono
Ripping of softwood Legno tenero lungo vena	●	
Ripping of hardwood Legno duro lungo vena	●	

# LG2A

## HW - Saw blades to cut wooden panels and composites HW - Lame per il taglio di pannelli di legno e composti

Saw blades suitable for ripping and crosscutting.

**Machines:** Circular saws, portable machines.

**Features:** ATB tooth with positive cutting angle.

**Material:** Soft and hard solid wood, unprocessed chipboard and plywood.

Lame per taglio lungo e trasverso vena.

**Macchine:** Seghe circolari, macchine portatili.

**Caratteristiche:** Dentatura alterna con angolo di taglio positivo.

**Materiale:** Legni massicci teneri e duri, pannelli stratificati, truciolari grezzi.

**FT01:** 2/7/42 + 2/9/46,4 + 2/10/60

**FT02:** 2/9/46,4 + 2/10/60



D	B	b	d	Z	NL	Code	SAP
mm	mm	mm	mm		FT	Codice	SAP
250	3,2	2,2	30	40	FT01	<b>LG2A 1700</b>	F03FS07562
300	3,2	2,2	30	36	FT01	<b>LG2A 1900</b>	F03FS07563
300	3,2	2,2	30	48	FT01	<b>LG2A 2100</b>	F03FS07564
350	3,5	2,5	30	54	FT02	<b>LG2A 2800</b>	F03FS07565

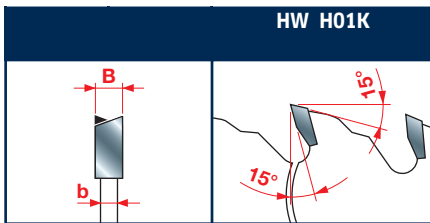
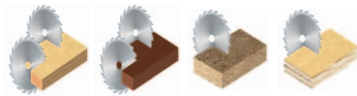

Tooth features - Caratteristiche del dente

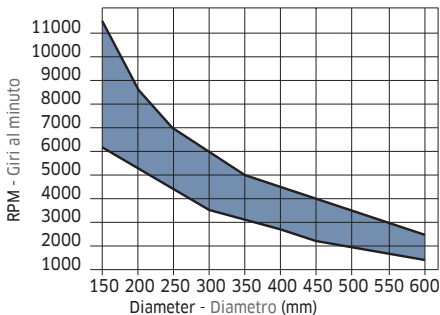

Minimum and maximum RPM based on the blade diameter.

Fascia del N. giri minimo e massimo consigliati in funzione del diametro della lama.

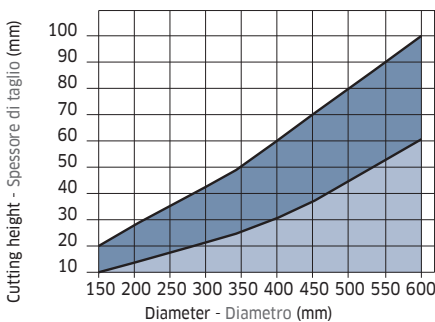

Maximum depth of rip and crosscut based on the blade diameter.

Altezza di taglio lungo e trasverso vena massima consentita in funzione del diametro della lama.

Solid wood  
 Legno massiccio

Wood-base materials  
 Materiali su base legno

	Ultimate Eccellente	High Ottimo	Good Buono
Ripping of solid wood Legno massiccio lungo vena		●	
Crosscutting of solid wood Legno massiccio trasverso vena		●	
Wood composites Composti di legno		●	

# LG2B

## HW - Saw blades to cut wooden panels and composites HW - Lame per il taglio di pannelli di legno e composti

Saw blades suitable for ripping and crosscutting.

**Machines:** Circular saws, portable machines.

**Features:** ATB 15° tooth with positive cutting angle.

**Material:** Soft, hard and exotic solid wood, unprocessed chipboard and plywood.

Lame per taglio lungo e trasverso vena.

**Macchine:** Seghe circolari, macchine portatili.

**Caratteristiche:** Dentatura alterna a 15° con angolo di taglio positivo.

**Materiale:** Legni massicci teneri, duri ed esotici, pannelli in legno stratificati, truciolari grezzi.

**FT01:** 2/7/42 + 2/9/46,4 + 2/10/60

**FT02:** 2/9/46,4 + 2/10/60

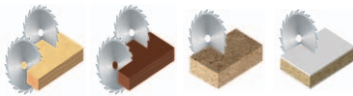

D	B	b	d	Z	NL	Code	SAP
mm	mm	mm	mm		FT	Code	SAP
250	3,2	2,2	30	60	FT01	<b>LG2B 0700</b>	F03FS07566
300	3,2	2,2	30	60	FT01	<b>LG2B 0900</b>	F03FS07567
300	3,2	2,2	30	72	FT01	<b>LG2B 1100</b>	F03FS07439
350	3,5	2,5	30	72	FT02	<b>LG2B 1400</b>	F03FS07568
350	3,5	2,5	30	84	FT02	<b>LG2B 1600</b>	F03FS07569

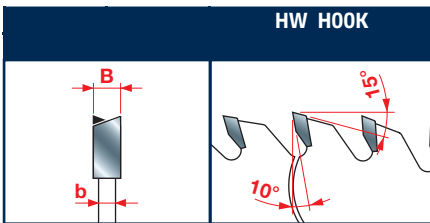

Tooth features - Caratteristiche del dente

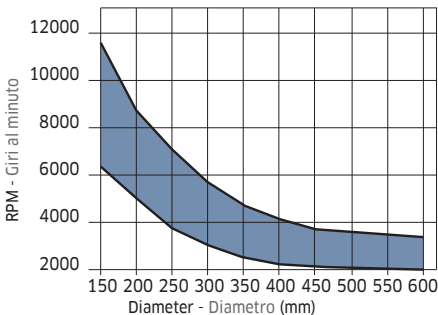

Minimum and maximum RPM based on the blade diameter.  
Fascia del N. giri minimo e massimo consigliati in funzione del diametro della lama.

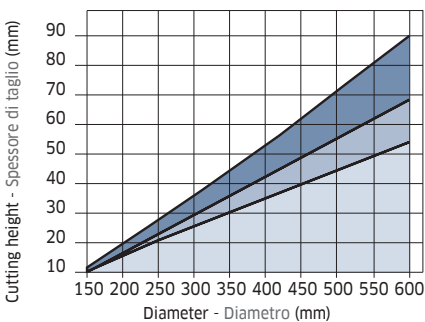

Maximum depth of rip and crosscut based on the blade diameter.  
Altezza di taglio lungo e trasverso vena massima consentita in funzione del diametro della lama.

Solid wood  
 Legno massiccio

Wood-base materials  
 Materiali su base legno

Plywood  
 Multistrato

	Ultimate Eccellente	High Ottimo	Good Buono
Ripping of solid wood Legno massiccio lungo vena		●	
Crosscutting of solid wood Legno massiccio trasverso vena		●	
Wood composites Composti di legno		●	

## HW - Saw blades to cut wooden panels and composites HW - Lame per il taglio di pannelli di legno e composti

Saw blades suitable for crosscutting.

**Machines:** Circular saws, portable machines.

**Features:** ATB 15° tooth with positive cutting angle.

**Material:** Soft, hard and exotic solid wood, chipboard, thermoplastic-wood composites, MDF laminated on one side.

Lame per taglio trasverso vena.

**Macchine:** Seghe circolari, macchine portatili.

**Caratteristiche:** Dentatura alterna a 15° con angolo di taglio positivo.

**Materiale:** Legni massicci teneri, duri, esotici, truciolari, termoplastici, MDF laminati su un solo lato.

**FT01:** 2/7/42 + 2/9/46,4 + 2/10/60

**FT02:** 2/9/46,4 + 2/10/60



D	B	b	d	Z	NL	Code	SAP
mm	mm	mm	mm		FT	Code	SAP
250	3,2	2,2	30	80	FT01	LG2C 1200	F03FS07570
300	3,2	2,2	30	96	FT01	LG2C 1500	F03FS07571
350	3,5	2,5	30	108	FT02	LG2C 2000	F03FS07572

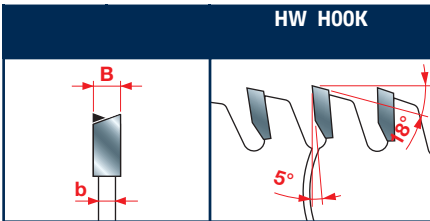
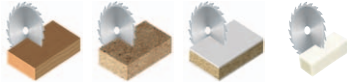

Tooth features - Caratteristiche del dente

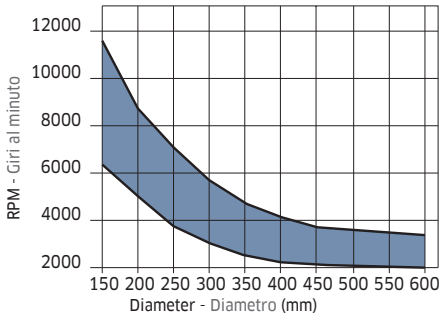

Minimum and maximum RPM based on the blade diameter.

Fascia del N. giri minimo e massimo consigliati in funzione del diametro della lama.

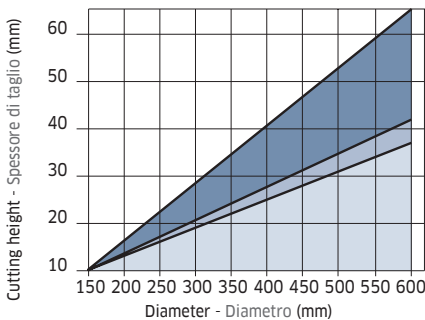

Maximum depth of crosscut based on the blade diameter.  
Altezza di taglio trasverso vena massima consentita in funzione del diametro della lama.

Solid wood  
 Legno massiccio

Wood-base materials  
 Materiali su base legno

Plywood  
 Multistrato

	Ultimate Eccellente	High Ottimo	Good Buono
Crosscutting of solid wood Legno massiccio trasverso vena		●	
Wood composites Composti di legno		●	
Plastic materials Materiali plastici		●	

## HW - Saw blades to cut bilaminated panels HW - Lame per il taglio di pannelli bilaminati

To size bilaminated panels with the employment of the scoring saw blade, in detail melamine-coated panels, with good finishing and long cutting life.

**Machines:** Circular saws, horizontal panel sizing machines.

**Features:** Flat-triple chip tooth with positive cutting angle.

**Material:** Bilaminated panels.

Per la sezionatura con l'ausilio della lama incisore di pannelli bilaminati, in particolare quelli rivestiti in melaminico, con buona finitura e lunga durata di taglio.

**Macchine:** Seghe circolari, sezionatrici orizzontali.

**Caratteristiche:** Dente piano-trapezoidale con angolo di taglio positivo.

**Materiale:** Pannelli bilaminati.



**FT01:** 2/7/42 + 2/9/46,4 + 2/10/60

**FT02:** 2/9/46,4 + 2/10/60

D mm	B mm	b mm	d mm	Z	NL FT	Code Codice	SAP SAP
250	3,2	2,2	30	80	FT01	LG3D 0400	F03FS07438
300	3,2	2,2	30	72	FT01	LG3D 2100	F03FS07437
300	3,2	2,2	30	96	FT01	LG3D 0600	F03FS07436
350	3,5	2,5	30	72	FT02	LG3D 2000	F03FS07573
350	3,5	2,5	30	108	FT02	LG3D 0900	F03FS07436

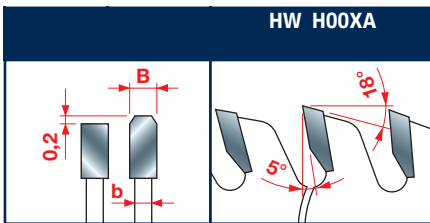
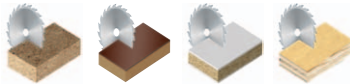

Tooth features - Caratteristiche del dente

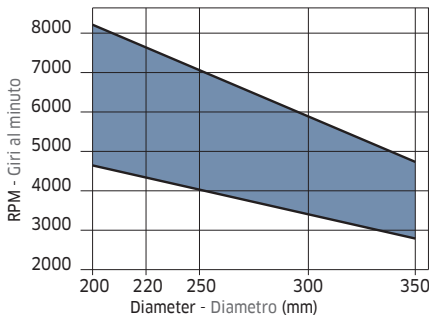

Minimum and maximum RPM based on the blade diameter.

Fascia del N. giri minimo e massimo consigliati in funzione del diametro della lama.

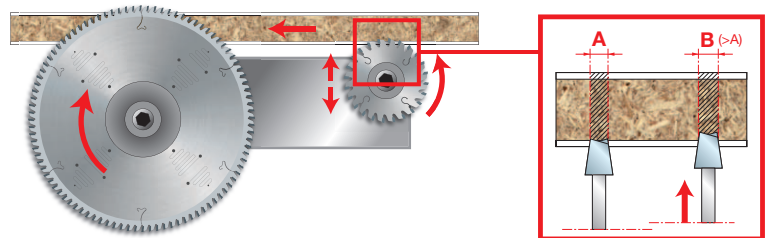

Cutting kerf of main saw blade  
Spessore lama principale

	Ultimate Eccellente	High Ottimo	Good Buono
Wood composites Composti di legno		●	
Laminates Laminati		●	

# Reference table of saw blades for panel sizing machines

## Tavola di riferimento delle lame per macchine sezionatrici

ANTHON						Main saw blade (Triple Chip - Flat) - Lama (Triple Chip - Piano)		
Machine type	D	B	b	d	Z	NL	Code	SAP
Tipo di macchina	mm	mm	mm	mm		FT	Codice	SAP
Anthon	530	5,8	4,0	60	60	1/11/85	LSB53002	F03FS04174
Anthon Inc	700	6,2	4,2	80	60	2/17/110	LSB70001	F03FS07036

ANTHON						Scoring saw blade (ATB/Conical) - Lama incisore (ATB/Conico)		
Machine type	D	B - B1	b	d	Z	NL	Code	SAP
Tipo di macchina	mm	mm	mm	mm		FT	Codice	SAP
Anthon	180	5,7 - 6,9	4,0	20	36		LI25M57NA3	F03FS02727

GABBIANI						Main saw blade (Triple Chip - Flat) - Lama (Triple Chip - Piano)		
Machine type	D	B	b	d	Z	NL	Code	SAP
Tipo di macchina	mm	mm	mm	mm		FT	Codice	SAP
Galaxy 90, Casadei	350	4,4	3,2	80	72	4/9/100 + 2/9/110 + 2/14/110	LSB35005	F03FS03947
Prima	355	4,4	3,2	80	72	4/9/100 + 2/9/110 + 2/14/110	LSB35506	F03FS03973
Scm Alpha	355	4,4	3,2	80	72	4/9/100 + 2/9/110 + 2/14/110	LSB35506	F03FS03973
Scm Sigma 115	400	4,4	3,2	80	60	4/9/100 + 2/9/110 + 2/14/110	LSB40011	F03FS04037
Class, Galaxy 115	400	4,4	3,2	80	72	4/9/100 + 2/9/110 + 2/14/110	LSB40012	F03FS04040
Galaxy 125	400	4,4	3,2	80	72	4/9/100 + 2/9/110 + 2/14/110	LSB40012	F03FS04040
Elite, Galaxy 140	450	4,4	3,2	80	72	2/9/130 + 4/19/120 + 2/14/110	LSB45009	F03FS04095
A10	500	4,4	3,2	80	60	4/9/100 + 2/9/110 + 2/14/110	LSB50004	F03FS04147

GABBIANI						Scoring saw blade (ATB/Conical) - Lama incisore (ATB/Conico)		
Machine type	D	B - B1	b	d	Z	NL	Code	SAP
Tipo di macchina	mm	mm	mm	mm		FT	Codice	SAP
Galaxy 90, Casadei	160	4,3 - 5,5	3,2	55	36	3/7/66 + 3/6/84	LI25M43LG3	F03FS02657
Prima	160	4,3 - 5,5	3,2	55	36	3/7/66 + 3/6/84	LI25M43LG3	F03FS02657
Scm Alpha	125	4,3 - 5,5	3,2	20	24		LI25M43FA3	F03FS02643
Scm Sigma 115	160	4,3 - 5,5	3,2	55	36	3/7/66 + 3/6/84	LI25M43LG3	F03FS02657
Class, Galaxy 115	160	4,3 - 5,5	3,2	55	36	3/7/66 + 3/6/84	LI25M43LG3	F03FS02657
Galaxy 125	160	4,3 - 5,5	3,2	55	36	3/7/66 + 3/6/84	LI25M43LG3	F03FS02657
Elite, Galaxy 140	160	4,3 - 5,5	3,2	55	36	3/7/66 + 3/6/84	LI25M43LG3	F03FS02657
A10	160	4,3 - 5,5	3,2	55	36	3/7/66 + 3/6/84	LI25M43LG3	F03FS02657

GIBEN						Main saw blade (Triple Chip - Flat) - Lama (Triple Chip - Piano)		
Machine type	D	B	b	d	Z	NL	Code	SAP
Tipo di macchina	mm	mm	mm	mm		FT	Codice	SAP
Smart 75	320	4,4	3,2	75	72	3/13/95	LSB32002	F03FS03933
Smart (Carro)	350	4,4	3,2	50	72	4/13/80	LSB35006	F03FS03950
Mk Gamma	355	4,4	3,2	75	72	4/15/105	LSB35505	F03FS03970
Trend/Prisim 1	355	4,4	3,2	75	54		LSB35502	F03FS03961
Trend/Prisim 1	355	4,4	3,2	75	72	4/15/105	LSB35505	F03FS03970
Starmatic	355	4,4	3,2	75	72	4/15/105	LSB35505	F03FS03970
Starmatic 850	355	4,4	3,2	75	72	4/15/105	LSB35505	F03FS03970
Prismatic 1	400	4,4	3,2	75	72	4/15/105	LSB40008	F03FS04029
2000	400	4,4	3,2	75	72	4/15/105	LSB40008	F03FS04029
Starmatic 1000	400	4,4	3,2	75	72	4/15/105	LSB40008	F03FS04029
Prismatic 2h 100	400	4,4	3,2	75	60	4/15/105	LSB40005	F03FS04020
Sigmatic 101	400	4,4	3,2	75	72	4/15/105	LSB40008	F03FS04029
Prismatic 2h 1115	430	4,4	3,2	75	60	4/15/105	LSB43005	F03FS04059
Prismatic2	430	4,4	3,2	75	72	4/15/105	LSB43008	F03FS04068
Prismatic3	470	4,4	3,2	75	72	4/15/105	LSB47003	F03FS04126
Tetramatic	470	4,4	3,2	75	60	4/15/105	LSB47002	F03FS04123
Giben	500	4,8	3,5	75	60	4/15/105	LSB50010	F03FS04160

# Reference table of saw blades for panel sizing machines

## Tavola di riferimento delle lame per macchine sezionatrici

GIBEN						Scoring saw blade (ATB/Conical) - Lama incisore (ATB/Conico)		
Machine type Tipo di macchina	D mm	B - B1 mm	b mm	d mm	Z	NL FT	Code Codice	SAP SAP
Smart 75	200	4,3 - 5,5	3,2	50	36	3/13/80	LI25M43PF3	F03FS02679
Smart (Carro)	180	4,3 - 5,5	3,2	50	36	3/13/80	LI25M43NF3	F03FS02666
Mk Gamma	125	4,3 - 5,5	3,2	45	24		LI25M43FE3	F03FS02645
Trend/Prisim 1	125	4,3 - 5,5	3,2	45	24		LI25M43FE3	F03FS02645
Trend/Prisim 1	125	4,3 - 5,5	3,2	45	24		LI25M43FE3	F03FS02645
Starmatic	215	4,3 - 5,5	3,2	50	42	2/7/80 + 3/15/80	LI25M43QF3	F03FS02685
Starmatic 850	160	4,3 - 5,5	3,2	45	36	3/11/70	LI25M43LE3	F03FS02655
Prismatic 1	160	4,3 - 5,5	3,2	45	36	3/11/70	LI25M43LE3	F03FS02655
2000	125	4,3 - 5,5	3,2	45	24		LI25M43FE3	F03FS02645
Starmatic 1000	215	4,3 - 5,5	3,2	50	42	2/7/80 + 3/15/80	LI25M43QF3	F03FS02685
Prismatic 2h 100	215	4,3 - 5,5	3,2	50	42	2/7/80 + 3/15/80	LI25M43QF3	F03FS02685
Sigmatic 101	215	4,3 - 5,5	3,2	50	42	2/7/80 + 3/15/80	LI25M43QF3	F03FS02685
Prismatic 2h 1115	215	4,3 - 5,5	3,2	50	42	2/7/80 + 3/15/80	LI25M43QF3	F03FS02685
Prismatic2	215	4,3 - 5,5	3,2	50	42	2/7/80 + 3/15/80	LI25M43QF3	F03FS02685
Prisamtic3	215	4,3 - 5,5	3,2	50	42	2/7/80 + 3/15/80	LI25M43QF3	F03FS02685
Tetramatic	215	4,3 - 5,5	3,2	50	42	2/7/80 + 3/15/80	LI25M43QF3	F03FS02685
Giben	125	4,3 - 5,5	3,2	45	24		LI25M43FE3	F03FS02645

HOLZMA						Main saw blade (Triple Chip - Flat) - Lama (Triple Chip - Piano)		
Machine type Tipo di macchina	D mm	B mm	b mm	d mm	Z	NL FT	Code Codice	SAP SAP
Holzma Typ 72	350	4,4	3,2	60	54	2/14/100	LSB35002	F03FS03938
Holzma Typ 82	380	4,4	3,2	60	72	2/14/100	LSB38002	F03FS03989
Holzma Typ 81/91	380	4,8	3,5	60	84	2/14/100	LSB38005	F03FS03996
Holzma Typ 01	400	4,8	3,5	60	72		LSB40013	F03FS04043
Holzma Typ 92	420	4,8	3,5	60	60	2/14/125	LSB42001	F03FS04045
Holzma Typ 92	420	4,8	3,5	60	84	2/14/100 + 2/14/125	LSB42002	F03FS04048
Holzma Typ 11	450	4,4	3,2	60	72	2/14/125	LSB45008	F03FS04092
Holzma Typ 22	500	4,8	3,5	60	60	2/11/115	LSB50009	F03FS04158
Holzma Typ 21	500	4,8	3,5	60	72	2/11/115	LSB50011	F03FS04162
Holzma Typ 23	520	4,8	3,5	60	60	2/19/120 + 2/11/115	LSB52002	F03FS04168
Holzma Typ 23	520	4,8	3,5	60	72	2/19/120 + 2/11/115	LSB52003	F03FS04170
Holzma Typ 42	570	4,8	3,5	60	60		LSB57001	F03FS04203
Holzma Typ 33	600	5,8	4,0	60	60	2/11/115 + 2/19/120	LSB60001	F03FS04207
Holzma Typ 33	600	5,8	4,0	60	72	2/11/115 + 2/19/120	LSB60002	F03FS04210
Holzma	670	5,8	4,2	60	60	2/19/120 + 2/11/148	LSB67001	F03FS04214
Holzma	670	5,8	4,2	60	72	2/19/120 + 2/11/148	LSB67002	F03FS04215
Holzma Typ 66	730	6,2	4,2	60	60	2/11/148 + 2/19/120	LSB73001	F03FS04220

HOLZMA						Scoring saw blade (ATB/Conical) - Lama incisore (ATB/Conico)		
Machine type Tipo di macchina	D mm	B - B1 mm	b mm	d mm	Z	NL FT	Code Codice	SAP SAP
Holzma Typ 72	180	4,3 - 5,5	3,2	45	36		LI25M43NE3	F03FS02664
Holzma Typ 82	180	4,7 - 5,9	3,5	45	36		LI25M47NE3	F03FS02715
Holzma Typ 81/91	200	4,7 - 5,9	3,5	45	36		LI25M47PE3	F03FS02719
Holzma Typ 01	180	4,7 - 5,9	3,5	45	36		LI25M47NE3	F03FS02715
Holzma Typ 92	200	4,7 - 5,9	3,5	45	36		LI25M47PE3	F03FS02719
Holzma Typ 92	200	4,7 - 5,9	3,5	45	36		LI25M47PE3	F03FS02719
Holzma Typ 11	180	4,7 - 5,9	3,5	45	36		LI25M47NE3	F03FS02715
Holzma Typ 22	200	4,7 - 5,9	3,5	45	36		LI25M47PE3	F03FS02719
Holzma Typ 21	200	4,7 - 5,9	3,5	45	36		LI25M47PE3	F03FS02719
Holzma Typ 23	200	4,7 - 5,9	3,5	45	36		LI25M47PE3	F03FS02719
Holzma Typ 23	200	4,7 - 5,9	3,5	45	36		LI25M47PE3	F03FS02719
Holzma Typ 42	200	5,7 - 6,9	4,0	45	36		LI25M57PE3	F03FS02728
Holzma Typ 33	200	5,7 - 6,9	4,0	45	36		LI25M57PE3	F03FS02728
Holzma Typ 33	200	5,7 - 6,9	4,0	45	36		LI25M57PE3	F03FS02728
Holzma	200	5,7 - 6,9	4,0	45	36		LI25M57PE3	F03FS02728
Holzma	200	5,7 - 6,9	4,0	45	36		LI25M57PE3	F03FS02728
Holzma Typ 66	200	6,1 - 7,3	4,2	45	36		LI25M61PE3	F03FS02731

# Reference table of saw blades for panel sizing machines

## Tavola di riferimento delle lame per macchine sezionatrici

HOMAG						Main saw blade (Triple Chip - Flat) - Lama (Triple Chip - Piano)			
Machine type	D	B	b	d	Z	NL	Code	SAP	
Tipo di macchina	mm	mm	mm	mm		FT	Codice	SAP	
Sawtech Chf 41	300	4,4	3,0	75	60		LSB30003	F03FS03916	
Sawtech Ch 30/06	355	4,4	3,2	75	72	4/15/105	LSB35505	F03FS03970	

HOMAG						Scoring saw blade (ATB/Conical) - Lama incisore (ATB/Conico)			
Machine type	D	B	b	d	Z	NL	Code	SAP	
Tipo di macchina	mm	mm	mm	mm		FT	Codice	SAP	
Sawtech Chf 41	200	4,3 - 5,5	3,2	45	36		LI25M43PE3	F03FS02676	
Sawtech Ch 30/06	200	4,3 - 5,5	3,2	45	36		LI25M43PE3	F03FS02676	

MAYER, IRION						Main saw blade (Triple Chip - Flat) - Lama (Triple Chip - Piano)			
Machine type	D	B	b	d	Z	NL	Code	SAP	
Tipo di macchina	mm	mm	mm	mm		FT	Codice	SAP	
Specific Models	305	4,4	3,0	30	60	2/10/60	LSB30501	F03FS03930	
Specific Models	400	4,4	3,2	30	72	2/10/60	LSB40007	F03FS04026	
Specific Models	500	4,4	3,2	30	72		LSB50005	F03FS04150	

MAYER, IRION						Scoring saw blade (ATB/Conical) - Lama incisore (ATB/Conico)			
Machine type	D	B - B1	b	d	Z	NL	Code	SAP	
Tipo di macchina	mm	mm	mm	mm		FT	Codice	SAP	
Specific Models	150	4,3 - 5,6	3,2	30	36		LI25M43KC3	F03FS02649	
Specific Models	150	4,3 - 5,6	3,2	30	36		LI25M43KC3	F03FS02649	
Specific Models	180	4,3 - 5,5	3,2	20	28		LI25M43NA3	F03FS02661	

PANHANS						Main saw blade (Triple Chip - Flat) - Lama (Triple Chip - Piano)			
Machine type	D	B	b	d	Z	NL	Code	SAP	
Tipo di macchina	mm	mm	mm	mm		FT	Codice	SAP	
Euro 10	305	4,4	3,0	30	60	2/10/60	LSB30501	F03FS03930	
Euro 30	350	4,4	3,2	30	72	2/10/60	LSB35003	F03FS03941	
Euro 693	350	4,4	3,2	30	72	2/10/60	LSB35003	F03FS03941	

PANHANS						Scoring saw blade (ATB/Conical) - Lama incisore (ATB/Conico)			
Machine type	D	B - B1	b	d	Z	NL	Code	SAP	
Tipo di macchina	mm	mm	mm	mm		FT	Codice	SAP	
Euro 10	125	4,3 - 5,5	3,2	20	24		LI25M43FA3	F03FS02643	
Euro 30	180	4,3 - 5,5	3,2	30	28	2/7/42 + 2/10/60	LI25M43NC3	F03FS02663	
Euro 693	180	4,3 - 5,5	3,2	30	28	2/7/42 + 2/10/60	LI25M43NC3	F03FS02663	

SCHEER						Main saw blade (Triple Chip - Flat) - Lama (Triple Chip - Piano)			
Machine type	D	B	b	d	Z	NL	Code	SAP	
Tipo di macchina	mm	mm	mm	mm		FT	Codice	SAP	
Fm 21	350	4,4	3,2	30	72	2/10/60	LSB35003	F03FS03941	
Fm 14	400	4,4	3,2	30	72	2/10/60	LSB40007	F03FS04026	
Fm 22	450	4,8	3,5	30	72	2/9/60	LSB45016	F03FS04109	

SCHEER						Scoring saw blade (ATB/Conical) - Lama incisore (ATB/Conico)			
Machine type	D	B - B1	b	d	Z	NL	Code	SAP	
Tipo di macchina	mm	mm	mm	mm		FT	Codice	SAP	
Fm 21	200	4,3 - 5,5	3,2	30	36	2/9/60	LI25M43PC3	F03FS02674	
Fm 14	200	4,3 - 5,5	3,2	30	36	2/9/60	LI25M43PC3	F03FS02674	
Fm 22	200	4,3 - 5,5	3,2	30	36	2/9/60	LI25M43PC3	F03FS02674	

# Reference table of saw blades for panel sizing machines

## Tavola di riferimento delle lame per macchine sezionatrici

SCHELLING						Main saw blade (Triple Chip - Flat) - Lama (Triple Chip - Piano)			
Machine type Tipo di macchina	D mm	B mm	b mm	d mm	Z	NL FT	Code Codice	SAP SAP	
Fl	460	4,4	3,2	30	72	2/13/94	LSB46001	F03FS04117	
Fw	500	4,4	3,2	30	60		LSB50003	F03FS04145	
Fw	500	4,4	3,2	30	72		LSB50005	F03FS04150	
Schelling	530	5,2	3,5	30	60		LSB53001	F03FS04172	
Ft	550	5,5	3,8	40	60	2/13/122	LSB55004	F03FS04188	
At	550	5,5	3,8	40	48	2/13/122	LSB55003	F03FS04186	
Schelling	620	6,2	4,2	40	60	2/13/114 + 2/13/140	LSB62001	F03FS04212	
Schelling	620	6,2	4,2	40	72	2/13/114 + 2/13/140	LSB62002	F03FS04213	
Schelling	670	6,2	4,2	40	60	2/17/140 + 2/13/140	LSB67003	F03FS04216	
Schelling	670	6,2	4,2	40	72	2/17/140 + 2/13/140	LSB67004	F03FS04217	
Schelling	680	6,2	4,2	40	60	2/13/140 + 2/17/140	LSB68001	F03FS04218	
Schelling	720	6,4	4,4	40	60	4/14/114 + 2/14/140	LSB72001	F03FS04219	

SCHELLING						Scoring saw blade (ATB/Conical) - Lama incisore (ATB/Conico)			
Machine type Tipo di macchina	D mm	B - B1 mm	b mm	d mm	Z	NL FT	Code Codice	SAP SAP	
Fl	200	4,3 - 5,5	3,2	20	36		LI25M43PA3	F03FS02670	
Fw	180	4,3 - 5,5	3,2	20	28		LI25M43NA3	F03FS02661	
Fw	180	4,3 - 5,5	3,2	20	28		LI25M43NA3	F03FS02661	
Schelling	200	5,1 - 6,3	3,5	20	36		LI25M51PA3	F03FS02725	
Ft	200	5,4 - 6,6	3,8	20	36		LI25M54PA3	F03FS02726	
At	200	5,4 - 6,6	3,8	20	36		LI25M54PA3	F03FS02726	
Schelling	200	6,1 - 7,3	4,2	20	36		LI25M61PA3	F03FS02730	
Schelling	200	6,1 - 7,3	4,2	20	36		LI25M61PA3	F03FS02730	
Schelling	200	6,1 - 7,3	4,2	20	36		LI25M61PA3	F03FS02730	
Schelling	200	6,1 - 7,3	4,2	20	36		LI25M61PA3	F03FS02730	
Schelling	200	6,1 - 7,3	4,2	20	36		LI25M61PA3	F03FS02730	
Schelling	220	6,3 - 7,5	4,4	20	36		LI25M63UA3	F03FS02732	

SCM						Main saw blade (Triple Chip - Flat) - Lama (Triple Chip - Piano)			
Machine type Tipo di macchina	D mm	B mm	b mm	d mm	Z	NL FT	Code Codice	SAP SAP	
Sigma 65	300	4,4	3,0	80	60	2/14/110 + 4/9/100	LSB30004	F03FS03918	

SCM						Scoring saw blade (ATB/Conical) - Lama incisore (ATB/Conico)			
Machine type Tipo di macchina	D mm	B - B1 mm	b mm	d mm	Z	NL FT	Code Codice	SAP SAP	
Sigma 65	160	4,3 - 5,5	3,2	55	36	3/7/66 + 3/6/84	LI25M43LG3	F03FS02657	

# Reference table of saw blades for panel sizing machines

## Tavola di riferimento delle lame per macchine sezionatrici

SELCO						Main saw blade (Triple Chip - Flat) - Lama (Triple Chip - Piano)			
Machine type Tipo di macchina	D mm	B mm	b mm	d mm	Z	NL FT	Code Codice	SAP SAP	
Eb70	300	4,4	3,0	65	60	2/9/110	LSB30002	F03FS03914	
Eb100	360	4,4	3,0	65	60	2/9/110	LSB36001	F03FS03978	
Eb100	360	4,4	3,2	65	72	2/9/110	LSB36002	F03FS03981	
Wn610	380	4,4	3,2	65	72	2/9/110	LSB38014	F03FS07266	
Eb110	400	4,4	3,2	80	60	4/19/120 + 2/9/130	LSB40006	F03FS04023	
Eb110	400	4,4	3,2	80	72	4/19/120 + 2/9/130	LSB40009	F03FS04032	
Eb120/Wn 600-122	430	4,4	3,2	80	72	2/9/130 + 4/19/120 + 2/14/110	LSB43009	F03FS04071	
Wn 600-132	450	4,4	3,2	80	72	2/9/130 + 4/19/120 + 2/14/110	LSB45009	F03FS04095	
Wn 600-145	480	4,8	3,5	80	72	2/9/130 + 4/19/120	LSB48001	F03FS04131	

SELCO						Scoring saw blade (ATB/Conical) - Lama incisore (ATB/Conico)			
Machine type Tipo di macchina	D mm	B - B1 mm	b mm	d mm	Z	NL FT	Code Codice	SAP SAP	
Eb70	200	4,3 - 5,5	3,2	65	36	2/9/100 + 2/9/110	LI25M43PI3	F03FS02681	
Eb100	200	4,3 - 5,5	3,2	65	36	2/9/100 + 2/9/110	LI25M43PI3	F03FS02681	
Eb100	200	4,3 - 5,5	3,2	65	36	2/9/100 + 2/9/110	LI25M43PI3	F03FS02681	
Wn610	200	4,3 - 5,5	3,2	65	36	2/9/100 + 2/9/110	LI25M43PI3	F03FS02681	
Eb110	300	4,3 - 5,5	3,2	65	72	2/9/110	LI25M43RI3	F03FS02689	
Eb110	200	4,3 - 5,5	3,2	65	36	2/9/100 + 2/9/110	LI25M43PI3	F03FS02681	
Eb120/Wn 600-122	200	4,3 - 5,5	3,2	65	36	2/9/100 + 2/9/110	LI25M43PI3	F03FS02681	
Wn 600-132	200	4,3 - 5,5	3,2	65	36	2/9/100 + 2/9/110	LI25M43PI3	F03FS02681	
Wn 600-145	200	4,7 - 5,9	3,5	65	36	2/9/100 + 2/9/110	LI25M47PI3	F03FS02720	

## HW - Panel sizing saw blades HW - Lame per la sezionatura di pannelli

To size single or multiple panels.

**Machines:** Horizontal panel sizing machines with scorer.

**Features:** ATB 10° tooth with positive cutting angle.

**Material:** Chipboard or MDF.

Per la sezionatura di pannelli singoli o in pacco.

**Macchine:** Sezionatrici orizzontali con incisore.

**Caratteristiche:** Dentatura alterna a 10° con angolo di taglio positivo.

**Materiale:** Pannelli in truciolare o MDF.

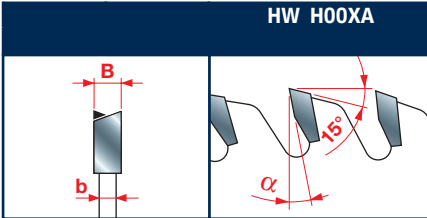
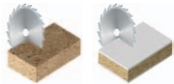

Tooth features - Caratteristiche del dente

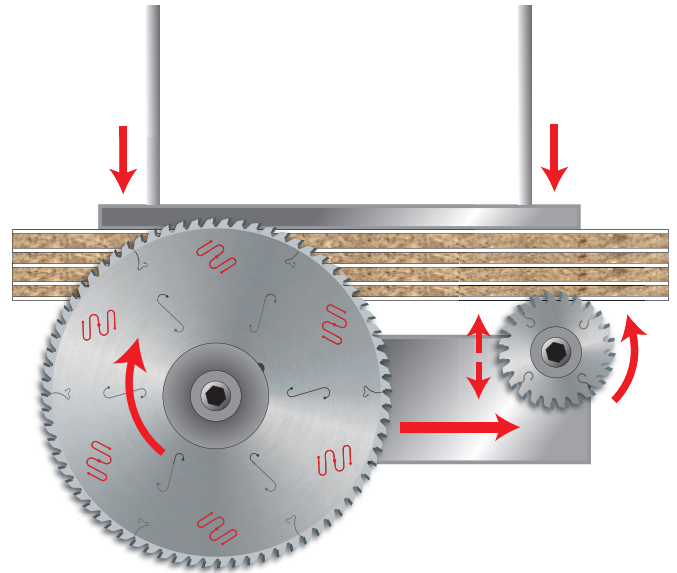

D mm	B mm	b mm	d mm	Z	α	NL FT	Machines Macchine	Code Codice	SAP SAP
350	4,4	3,2	30	54	10°	2/10/60	Panhans, SCM, Scheer	LSA35004	F03FS03819
350	4,4	3,2	75	54	10°			LSA35005	F03FS03822
355	4,4	3,2	30	54	10°	2/10/60		LSA35504	F03FS03830
355	4,4	3,2	75	54	10°	4/15/105	Giben	LSA35505	F03FS03833
355	4,4	3,2	80	54	10°	4/9/100 + 2/14/110	Gabbiani	LSA35506	F03FS03835
380	4,4	3,0	30	48	10°	2/10/60		LSA38001	F03FS03838
380	4,4	3,2	80	48	15°	4/9/100 + 2/9/110 + 2/14/110	Gabbiani	LSA38002	F03FS07175
400	4,4	3,2	30	48	15°			LSA40001	F03FS03843
400	4,4	3,2	75	48	15°	4/15/105	Giben	LSA40002	F03FS03845
400	4,4	3,2	80	48	15°	4/9/100 + 2/9/110 + 2/14/110	Gabbiani	LSA40008	F03FS03863
400	4,4	3,2	30	60	15°	2/10/60		LSA40004	F03FS03851
400	4,4	3,2	75	60	15°	4/15/105	Giben	LSA40005	F03FS03854
400	4,4	3,2	80	60	10°	4/9/100 + 2/9/110 + 2/14/110	Gabbiani	LSA40007	F03FS03860
400	4,4	3,2	80	60	15°	2/9/130 + 4/19/120	Selco	LSA40006	F03FS03857
410	4,4	3,2	30	48	15°			LSA41001	F03FS03866
410	4,4	3,2	80	48	15°	4/9/100 + 2/9/110 + 2/14/110	Gabbiani	LSA41002	F03FS03868
420	4,4	3,2	30	60	15°			LSA42001	F03FS07176
420	4,4	3,2	80	60	15°	4/9/100 + 2/9/110 + 2/14/110	Gabbiani	LSA42002	F03FS03871
430	4,4	3,2	30	60	15°			LSA43001	F03FS03874
450	4,4	3,2	30	48	15°	02/10/60		LSA45001	F03FS03879
450	4,4	3,2	30	60	15°	2/9/60		LSA45003	F03FS03884
450	4,4	3,2	80	60	15°	2/9/130 + 4/19/120	Selco	LSA45004	F03FS03887
500	4,4	3,2	30	60	15°			LSA50004	F03FS03895
500	4,4	3,2	75	60	15°	4/15/105	Giben	LSA50005	F03FS03897
500	4,8	3,5	80	60	15°	4/9/100 + 2/9/110 + 2/14/110	Gabbiani	LSA50006	F03FS03899
550	5,2	3,5	30	48	15°			LSA55001	F03FS03901
550	5,2	3,5	75	48	15°	4/15/105	Giben	LSA55002	F03FS03904
550	5,5	3,8	80	48	15°	4/9/100 + 2/9/110 + 2/14/110	Gabbiani	LSA55003	F03FS03907
565	5,2	3,5	100	48	15°		Giben	LSA56501	F03FS03910

## HW - Panel sizing saw blades HW - Lama per la sezionatura di pannelli

To size single or multiple panels.

**Machines:** Horizontal panel sizing machines with scorer.

**Features:** Triple chip tooth with positive cutting angle.

**Material:** Chipboard or MDF laminated with melamine or plastic materials.

Per la sezionatura di pannelli singoli o in pacco.

**Macchine:** Sezionatrici orizzontali con incisore.

**Caratteristiche:** Dente piano-trapezoidale con angolo di taglio positivo.

**Materiale:** Pannelli in truciolare o MDF rivestiti in melaminico o materiali plastici.

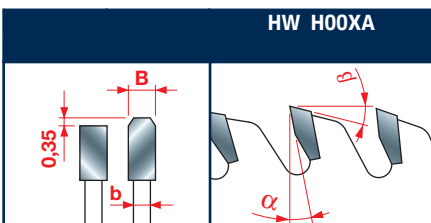
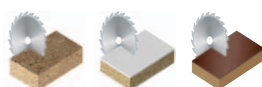
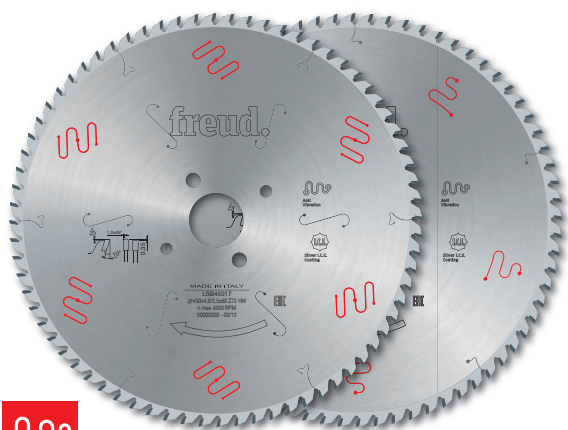

Tooth features - Caratteristiche del dente

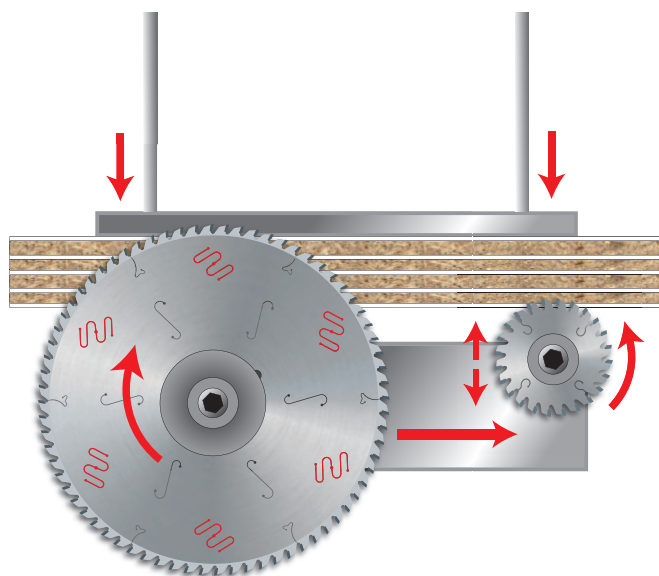

D	B	b	d	Z	$\alpha$	$\beta$	NL	Machines	Code	SAP	Code	SAP
mm	mm	mm	mm				FT	Macchine	Code	SAP	Code	SAP
Silver I.C.E. Coating												
Extended												
250	4,2	3,0	55	48	15°	15°		Techmatic		LSB25001	F03FS06974	
250	4,2	3,0	30	60	15°	15°		Techmatic		LSB25003	F03FS07367	
250	4,2	3,0	55	60	15°	15°		Techmatic		LSB25002	F03FS07366	
250	4,4	3,0	30	80	15°	15°	2/9/46,4 + 2/10/60			LSB25004	F03FS07372	
300	4,4	3,0	30	60	10°	15°	2/10/60	Panhans		LSB30001	F03FS03912	LSB30001X
300	4,4	3,0	75	60	10°	15°		Homag		LSB30003	F03FS03916	
300	4,4	3,0	80	60	10°	15°	4/9/100 + 2/14/110	SCM		LSB30004	F03FS03918	
300	4,4	3,0	30	72	10°	15°	2/10/60	Panhans		LSB30005	F03FS03920	LSB30005X
300	4,4	3,0	65	72	10°	15°	2/9/110	Selco		LSB30006	F03FS03922	
300	4,4	3,0	75	72	10°	15°		Holzma		LSB30007	F03FS03924	
300	4,4	3,0	80	72	10°	15°	4/9/100 + 2/14/110	SCM		LSB30008	F03FS03926	LSB30008X
300	4,4	3,0	65	60	10°	15°	2/9/110	Selco		LSB30002	F03FS03914	
300	4,4	3,2	65	60	10°	15°	2/9/110	Selco		LSB30011		
305	4,4	3,0	30	60	10°	15°	2/10/60	Mayer, Panhans, SCM		LSB30501	F03FS03930	
320	4,4	3,2	30	60	10°	15°				LSB32005	F03FS06570	
320	4,4	3,2	50	60	10°	15°	3/15/80 + 3/13/95	Giben		LSB32004	F03FS06569	
320	4,4	3,2	65	60	10°	15°	2/9/110	Selco		LSB32003	F03FS06027	
320	4,4	3,2	65	72	10°	15°	2/9/110	Selco		LSB32001	F03FS03931	LSB32001X
320	4,4	3,2	75	72	10°	15°	3/13/95	Giben		LSB32002	F03FS03933	
350	4,4	3,2	30	54	10°	15°	2/10/60	Panhans, Scheer		LSB35001	F03FS03935	
350	4,4	3,2	60	54	10°	15°	2/14/100	Holzma		LSB35002	F03FS03938	
350	4,4	3,2	30	72	10°	15°	2/10/60	Panhans, Scheer		LSB35003	F03FS03941	LSB35003X F03FS07630
350	4,4	3,2	50	72	10°	15°	4/13/80	Giben		LSB35006	F03FS03950	LSB35006X
350	4,4	3,2	60	72	10°	15°	2/14/100	Holzma		LSB35004	F03FS03944	LSB35004X F03FS07636
350	4,4	3,2	75	72	10°	15°		Giben		LSB35008	F03FS03954	LSB35008X F03FS07634
350	4,4	3,2	80	72	10°	15°	4/9/100+2/9/110+2/14/110	Gabbiani		LSB35005	F03FS03947	LSB35005X F03FS07635
350	4,2	3,2	80	84	15°	15°				LSB35012	F03FS07548	
350	4,2	3,2	80	96	15°	15°				LSB35011	F03FS07547	
355	4,4	3,2	75	54	10°	15°		Giben		LSB35502	F03FS03961	
355	4,4	3,2	80	54	10°	15°	4/9/100+2/9/110+2/14/110	Gabbiani		LSB35503	F03FS03964	

D	B	b	d	Z	α	β	NL	Machines	Code	SAP	Code	SAP
mm	mm	mm	mm		°	°	FT	Macchine	Codice	SAP	Codice	SAP
									Silver I.C.E. Coating		Extended	
355	4,4	3,2	30	72	10°	15°	2/10/60	Panhans, SCM		LSB35504	F03FS03967	LSB35504X
355	4,4	3,2	65	72	15°	15°	2/9/110	Selco		LSB35508		
355	4,4	3,2	75	72	10°	15°	4/15/105	Giben		LSB35505	F03FS03970	LSB35505X
355	4,4	3,2	75	72	10°	15°	3/7/100	Gabbiani		LSB35507	F03FS03976	LSB35507X
355	4,4	3,2	80	72	10°	15°	4/9/100+2/9/110+2/14/110	Gabbiani		LSB35506	F03FS03973	
360	4,4	3,0	65	60	10°	15°	2/9/110	Selco		LSB36001	F03FS03978	
360	4,4	3,2	65	72	10°	15°	2/9/110	Selco		LSB36002	F03FS03981	LSB36002X
370	4,4	3,2	30	72	10°	15°	2/10/60	Schelling		LSB37001	F03FS03984	
380	4,4	3,2	80	48	10°	15°	4/9/100+2/9/110+2/14/110	Gabbiani		LSB38009	F03FS04006	
380	4,4	3,2	50	60	10°	15°	4/13/80	Giben		LSB38007	F03FS04000	
380	4,4	3,2	60	60	10°	15°	2/14/100	Holzma		LSB38001	F03FS03986	LSB38001X
380	4,4	3,2	30	72	10°	15°	02/08/83			LSB38011		
380	4,4	3,2	50	72	10°	15°	4/13/80	Giben		LSB38008	F03FS04003	
380	4,4	3,2	60	72	10°	15°	2/14/100	Holzma		LSB38002	F03FS03989	LSB38002X F03FS07631
380	4,4	3,2	65	72	10°	15°	2/9/110	Selco		LSB38014	F03FS07266	
380	4,4	3,2	75	72	10°	15°	2/14/100	Holzma		LSB38012	F03FS05805	LSB38012
380	4,4	3,2	80	72	10°	15°	4/9/100+2/9/110+2/14/110	Gabbiani		LSB38010	F03FS04008	LSB38010X
380	4,4	3,2	80	96	10°	15°	4/9/100+2/9/110+2/14/110	Gabbiani		LSB38013	F03FS06258	LSB38013X
380	4,8	3,5	60	60	10°	15°	2/14/100	Holzma		LSB38003	F03FS03992	
380	4,8	3,5	60	72	10°	15°	2/14/100	Holzma		LSB38004	F03FS03994	LSB38004X F03FS07632
380	4,8	3,5	60	84	10°	15°	2/14/100	Holzma		LSB38005	F03FS03996	LSB38005X
390	4,4	3,2	80	72	10°	15°	2/14/110	Sigma		LSB39001	F03FS04010	
400	4,4	3,2	30	48	10°	15°				LSB40001	F03FS04011	
400	4,4	3,2	75	48	15°	15°	4/15/105	Giben		LSB40002	F03FS04013	
400	4,4	3,2	80	48	15°	15°	2/9/110+4/9/100+2/14/110	Gabbiani		LSB40010	F03FS04035	
400	4,4	3,2	30	60	15°	15°	2/10/60			LSB40004	F03FS04017	
400	4,4	3,2	75	60	15°	15°	4/15/105	Giben		LSB40005	F03FS04020	
400	4,4	3,2	80	60	15°	15°	2/9/130 + 4/19/120	Selco		LSB40006	F03FS04023	
400	4,4	3,2	80	60	15°	15°	4/9/100+2/9/110+2/14/110	Gabbiani		LSB40011	F03FS04037	
400	4,4	3,2	30	72	10°	15°	2/10/60	Scheer		LSB40007	F03FS04026	LSB40007X
400	4,4	3,2	65	72	15°	15°	2/9/110	Selco		LSB40016		
400	4,4	3,2	75	72	10°	15°	4/15/105	Giben		LSB40008	F03FS04029	LSB40008X
400	4,4	3,2	80	72	10°	15°	2/9/130 + 4/19/120	Selco		LSB40009	F03FS04032	LSB40009X
400	4,4	3,2	80	72	10°	15°	4/9/100+2/9/110+2/14/110	Gabbiani		LSB40012	F03FS04040	
400	4,6	3,2	35	72	10°	15°		Euromac		LSB40015	F03FS05981	
400	4,8	3,5	60	72	10°	15°		Holzma		LSB40013	F03FS04043	LSB40013X
420	4,4	3,2	80	60	10°	15°	4/9/100+2/9/110+2/14/110	Gabbiani		LSB42004	F03FS06028	
420	4,4	3,2	50	72	10°	15°	4/13/80	Giben		LSB42006	F03FS06544	
420	4,4	3,2	80	72	10°	15°	4/9/100+2/9/110+2/14/110	Gabbiani		LSB42005	F03FS06029	
420	4,8	3,5	60	60	15°	15°	2/14/125	Holzma		LSB42001	F03FS04045	
420	4,8	3,5	60	84	10°	15°	2/14/100+2/14/125	Holzma		LSB42002	F03FS04048	
430	4,4	3,2	30	48	15°	15°				LSB43001	F03FS04050	
430	4,4	3,2	75	48	15°	15°	4/15/105	Giben		LSB43002	F03FS04052	
430	4,4	3,2	30	60	15°	15°	2/10/60			LSB43004	F03FS04057	
430	4,4	3,2	75	60	15°	15°	4/15/105	Giben		LSB43005	F03FS04059	
430	4,4	3,2	80	60	15°	15°	2/9/130+2/14/110+4/19/120	Selco - Gabbiani		LSB43006	F03FS04062	
430	4,4	3,2	30	72	15°	15°				LSB43007	F03FS04065	
430	4,4	3,2	65	72	10°	15°	2/9/110	Selco		LSB43012	F03FS07457	
430	4,4	3,2	75	72	10°	15°	4/15/105	Giben		LSB43008	F03FS04068	LSB43008X
430	4,4	3,2	80	72	10°	15°	2/9/130+2/14/110+4/19/120	Selco - Gabbiani		LSB43009	F03FS04071	LSB43009X
430	4,4	3,2	75	96	10°	15°	4/15/105	Giben Prismatic		LSB43010	F03FS04074	
430	4,8	3,5	70	72	15°	15°	4/11/130	Selco		LSB43013		
450	4,4	3,2	30	48	15°	15°	2/9/60	Mayer, Panhans, SCM		LSB45001	F03FS04076	
450	4,4	3,2	60	48	15°	15°	2/14/125	Holzma		LSB45002	F03FS04078	
450	4,4	3,2	80	48	15°	15°	2/9/130+4/19/120+2/14/110	Selco - Gabbiani		LSB45003	F03FS04080	
450	4,4	3,2	30	60	15°	15°	02/10/60	Mayer, Panhans, SCM		LSB45004	F03FS04083	
450	4,4	3,2	60	60	15°	15°	2/14/125	Holzma		LSB45005	F03FS04085	
450	4,4	3,2	80	60	10°	15°	2/9/130+4/19/120+2/14/110	Selco - Gabbiani		LSB45006	F03FS04087	

D	B	b	d	Z	α	β	NL	Machines	Code	SAP	Code	SAP
mm	mm	mm	mm		°	°	FT	Macchine	Codice	SAP	Codice	SAP
									Silver I.C.E. Coating		Extended	
450	4,4	3,2	30	72	10°	15°	2/10/60	Mayer, Panhans, SCM		<b>LSB45007</b>	F03FS04090	
450	4,4	3,2	60	72	10°	15°	2/14/125	Holzma		<b>LSB45008</b>	F03FS04092	
450	4,4	3,2	80	72	10°	15°	2/9/130+2/14/110+4/19/120	Selco - Gabbiani		<b>LSB45009</b>	F03FS04095	<b>LSB45009X</b>
450	4,8	3,5	30	72	10°	15°	02/09/60	Scheer		<b>LSB45016</b>	F03FS04109	
450	4,8	3,5	60	72	10°	15°	2/14/125 + 2/17/100	Holzma		<b>LSB45017</b>	F03FS04111	<b>LSB45017X</b> F03FS07391
450	4,8	3,5	80	72	10°	15°	2/9/130 + 4/19/120	Selco		<b>LSB45018</b>	F03FS04114	<b>LSB45018X</b>
450	4,8	3,5	60	84	10°	15°	2/14/125	Holzma		<b>LSB45019</b>	F03FS06177	
460	4,4	3,2	30	72	10°	15°	2/13/94	Schelling		<b>LSB46001</b>	F03FS04117	
470	4,4	3,2	75	48	15°	15°	4/15/105	Giben		<b>LSB47001</b>	F03FS04120	
470	4,4	3,2	75	60	15°	15°	4/15/105	Giben		<b>LSB47002</b>	F03FS04123	
470	4,4	3,2	75	72	10°	15°	4/15/105	Giben		<b>LSB47003</b>	F03FS04126	
470	4,4	3,2	75	96	10°	15°	4/15/105	Giben		<b>LSB47004</b>	F03FS04129	
470	4,8	3,5	70	72	15°	15°	4/11/130	Selco		<b>LSB47005</b>		
480	4,8	3,5	80	48	15°	15°	2/9/130+2/14/110+4/19/120	Selco - Gabbiani		<b>LSB48002</b>	F03FS04134	
480	4,8	3,5	80	60	15°	15°	2/9/130 + 4/19/120	Selco		<b>LSB48003</b>	F03FS04136	
480	4,8	3,5	30	72	10°	15°	2/10/60	Schelling		<b>LSB48004</b>	F03FS04138	
480	4,8	3,5	80	72	10°	15°	2/9/130 + 4/19/120	Selco		<b>LSB48001</b>	F03FS04131	
500	4,4	3,2	80	48	15°	15°	4/9/100+2/9/110+2/14/110	Gabbiani		<b>LSB50002</b>	F03FS04142	
500	4,4	3,2	30	60	15°	15°		Schelling		<b>LSB50003</b>	F03FS04145	
500	4,4	3,2	80	60	15°	15°	4/9/100+2/9/110+2/14/110	Gabbiani		<b>LSB50004</b>	F03FS04147	
500	4,4	3,2	30	72	15°	15°		Schelling		<b>LSB50005</b>	F03FS04150	
500	4,8	3,5	60	48	15°	15°	2/11/115	Holzma		<b>LSB50007</b>	F03FS04154	
500	4,8	3,5	60	60	15°	15°	2/11/115	Holzma		<b>LSB50009</b>	F03FS04158	
500	4,8	3,5	75	60	15°	15°	4/15/105	Giben		<b>LSB50010</b>	F03FS04160	
500	4,8	3,5	60	72	15°	15°	2/11/115	Holzma		<b>LSB50011</b>	F03FS04162	
500	4,8	3,5	75	72	15°	15°	4/15/105	Giben		<b>LSB50012</b>	F03FS04164	
510	4,8	3,5	80	72	15°	15°	2/9/130 + 4/19/120	Selco		<b>LSB51001</b>	F03FS06220	
520	4,4	3,2	30	54	15°	15°	2/13/94	Schelling		<b>LSB52005</b>	F03FS06799	
520	4,8	3,5	60	60	15°	15°	2/11/115 + 2/19/120	Holzma		<b>LSB52002</b>	F03FS04168	
520	4,8	3,5	60	72	15°	15°	2/11/115 + 2/19/120	Holzma		<b>LSB52003</b>	F03FS04170	
520	4,8	3,5	70	72	18°	13°	4/11/130	Selco		<b>LSB52006</b>	F03FS07659	
530	5,2	3,5	30	60	15°	15°		Schelling		<b>LSB53001</b>	F03FS04172	
530	5,8	4,0	60	60	15°	15°	01/11/85	Anthon		<b>LSB53002</b>	F03FS04174	
540	4,8	3,5	60	60	15°	15°	2/11/115 + 2/19/120	Holzma Typ 33		<b>LSB54002</b>	F03FS04178	
540	4,8	3,5	60	72	15°	15°	2/11/115 + 2/19/120	Holzma Typ 33		<b>LSB54003</b>	F03FS04180	
540	5,8	4,0	60	60	15°	15°	01/11/85	Anthon		<b>LSB54004</b>	F03FS06030	
550	5,2	3,5	80	48	15°	15°	2/14/110	Gabbiani		<b>LSB55005</b>	F03FS04190	
550	5,2	3,5	60	60	15°	15°				<b>LSB55002</b>	F03FS04184	
550	5,2	3,5	80	60	15°	15°	2/14/110	Gabbiani		<b>LSB55006</b>	F03FS04192	
550	5,5	3,8	40	48	15°	15°	2/13/122	Schelling		<b>LSB55003</b>	F03FS04186	
550	5,5	3,8	40	60	15°	15°	2/13/122	Schelling		<b>LSB55004</b>	F03FS04188	
565	5,2	3,5	80	48	15°	15°	2/14/110 + 4/9/100	Gabbiani		<b>LSB56503</b>	F03FS04200	
565	5,2	3,5	100	48	15°	15°		Giben		<b>LSB56501</b>	F03FS04195	
565	5,2	3,5	100	60	15°	15°		Giben		<b>LSB56502</b>	F03FS04197	
570	4,8	3,5	60	60	15°	15°		Holzma		<b>LSB57001</b>	F03FS04203	
600	5,8	4,0	60	60	15°	15°	2/11/115 + 2/19/120	Holzma Typ 33		<b>LSB60001</b>	F03FS04207	
600	5,8	4,0	60	72	15°	15°	2/11/115 + 2/19/120	Holzma Typ 33		<b>LSB60002</b>	F03FS04210	
620	6,2	4,2	40	60	18°	13°	2/13/114 + 2/13/140	Schelling		<b>LSB62001</b>	F03FS04212	
620	6,2	4,2	40	72	15°	15°	2/13/114 + 2/13/140	Schelling		<b>LSB62002</b>	F03FS04213	
670	5,8	4,2	60	60	18°	13°	2/11/148 + 2/19/120	Holzma		<b>LSB67001</b>	F03FS04214	
670	5,8	4,2	60	72	15°	15°	2/11/148 + 2/19/120	Holzma		<b>LSB67002</b>	F03FS04215	
670	6,2	4,2	40	60	18°	13°	2/17/140 + 2/13/140	Schelling		<b>LSB67003</b>	F03FS04216	
670	6,2	4,2	40	72	15°	15°	2/17/140 + 2/13/140	Schelling		<b>LSB67004</b>	F03FS04217	
680	6,2	4,2	40	60	18°	13°	2/13/140 + 2/17/140	Schelling		<b>LSB68001</b>	F03FS04218	
700	6,2	4,2	80	60	18°	15°	2/17/110	Anthon LNC		<b>LSB70001</b>	F03FS07036	
720	6,4	4,4	40	60	18°	15°	2/14/114 + 2/14/140	Schelling		<b>LSB72001</b>	F03FS04219	
730	6,2	4,2	60	60	18°	15°	2/11/148 + 2/19/120	Holzma Typ 66		<b>LSB73001</b>	F03FS04220	

## HW - "Supercut" panel sizing saw blades with variable pitch HW - Sezionatrici "Supercut" con dentatura a passo variabile per pannelli laminati

To size single or multiple panels.

**Machines:** Horizontal panel sizing machines with scorer.

**Features:** Triple chip tooth with positive cutting angle. Perfect for cutting at high feed rates to increase production throughput. Due to the precision cutting edge and resulting flawless finish no additional machining is needed before edge banding. The LSC Saw blade line was developed to achieve the highest possible feed rate with best possible finish available in the market. Performance = Productivity! freud's new exclusively patented vibration reduction reeds are strategically placed and engineered to give the greatest reduction in noise and vibration available in the market today. Benefits of the Technology result in a best in class performance for cutting both single sheets or stacked sheets on today's panel processing equipment.

**Material:** Chipboard or laminated wood composite materials.

Per la sezionatura di pannelli singoli o in pacco.

**Macchine:** Sezionatrici orizzontali con incisore.

**Caratteristiche:** Dente trapezoidale con angolo di taglio positivo. Ideali per la squadratura di pannelli dove viene richiesta una perfetta finitura dei bordi laminati. Grazie all'ottimo grado di finitura di taglio si escludono ulteriori lavorazioni del pannello per la successiva fase di bordatura. Geometria della lama studiata per ottenere il massimo rendimento soprattutto nei casi di avanzamenti elevati di taglio. Dotate di intagli afoni stuccati posizionati in prossimità della corona dentata, per ridurre al massimo la rumorosità e le vibrazioni durante l'impiego. Si ottengono così le migliori performance anche nella sezionatura di più pannelli sovrapposti.

**Materiale:** Pannelli laminati in truciolare e altri composti di legno.

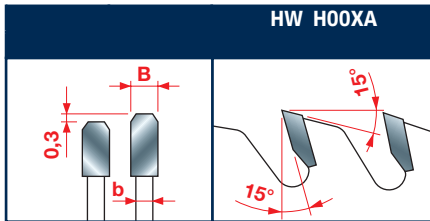
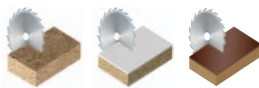
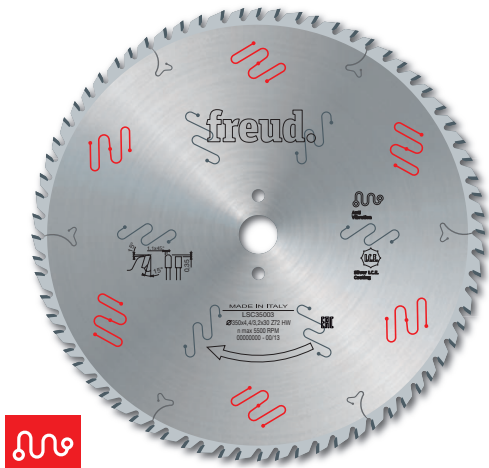

Tooth features - Caratteristiche del dente

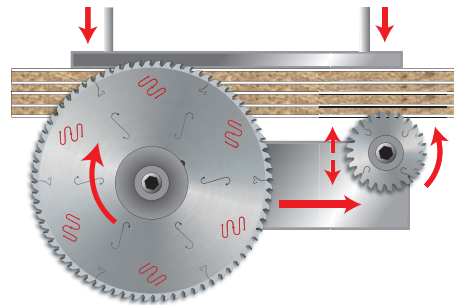

D mm	B mm	b mm	d mm	Z	NL FT	Machines Macchine	Code Codice	SAP SAP
300	4,4	3,0	30	60	2/10/60	Panhans	LSC30001	F03FS06322
300	4,4	3,0	65	60	2/9/110	Selco	LSC30002	F03FS06325
300	4,4	3,0	75	60		Holzma	LSC30003	F03FS06326
300	4,4	3,0	80	60	2/14/110 + 4/9/100	SCM	LSC30004	F03FS06327
320	4,4	3,2	50	60	3/15/80 + 3/13/95	Giben	LSC32004	F03FS06328
320	4,4	3,2	65	60	2/9/110	Selco	LSC32003	F03FS06329
350	4,4	3,2	30	72	2/10/60	Panhans-Scheer	LSC35003	F03FS06305
350	4,4	3,2	50	72	4/13/80	Giben	LSC35006	F03FS06309
350	4,4	3,2	60	72	2/14/100	Holzma	LSC35004	F03FS06310
350	4,4	3,2	80	72	4/9/100+2/9/110+2/14/110	Gabbiani	LSC35005	F03FS06311
355	4,4	3,2	30	72	02/10/60	Panhans-SCM	LSC35504	F03FS06306
355	4,4	3,2	75	72		Giben	LSC35505	F03FS06307
360	4,4	3,2	65	72	2/9/110	Selco	LSC36002	F03FS06308
370	4,4	3,2	30	72	02/10/60	Schelling	LSC37001	F03FS06312
380	4,4	3,2	50	72	4/13/80	Giben	LSC38008	F03FS06343
380	4,4	3,2	60	72	2/14/100	Holzma	LSC38002	F03FS06313
380	4,4	3,2	80	72	4/9/100+2/9/110+2/14/110	Gabbiani	LSC38010	F03FS06314
380	4,8	3,5	60	72	2/14/100	Holzma	LSC38004	F03FS06332
400	4,4	3,2	30	72	02/10/60	Scheer	LSC40007	F03FS06315
400	4,4	3,2	75	72	4/15/105	Giben	LSC40008	F03FS06317
400	4,4	3,2	80	72	4/19/120 + 2/9/130	Selco	LSC40009	F03FS06319
400	4,4	3,2	80	72	4/9/100+2/9/110+2/14/110	Gabbiani	LSC40012	F03FS06320
430	4,4	3,2	75	72	4/15/105	Giben	LSC43008	F03FS06316
430	4,4	3,2	80	72	2/9/130+4/19/120+2/14/110	Selco-Gabbiani	LSC43009	F03FS06321
450	4,4	3,2	60	72	2/14/125	Holzma	LSC45008	F03FS06318
450	4,8	3,5	60	72	2/14/125	Holzma	LSC45017	F03FS06323
450	4,8	3,5	80	72	2/9/130 + 4/19/120	Selco	LSC45018	F03FS06324

# LI25M

## HW - Conical scoring saw blades HW - Lama incisore coniche

To score the coating on bilaminated panels.

**Machines:** Horizontal panel sizing machines that allow vertical adjustment of the scorer in relation to the panel sizing saw blade kerf.

**Features:** ATB 6° tooth with positive cutting angle.

**Material:** Bilaminated chipboard or MDF.

Per l'incisione del rivestimento di pannelli bilaminati.

**Macchine:** Sezionatrici orizzontali con l'albero dell'incisore regolabile in altezza in funzione dello spessore di taglio della lama sezionatrice.

**Caratteristiche:** Dentatura alterna a 6° con angolo di taglio positivo.

**Materiale:** Pannelli in truciolare o MDF bilaminati.

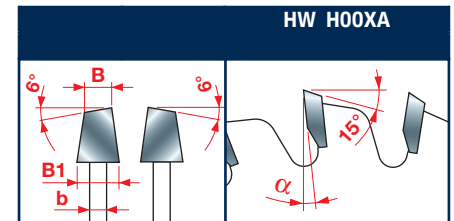

Tooth features - Caratteristiche del dente

D mm	B - B1 mm	b mm	d mm	Z	α	NL FT	Machines Macchine	Code Codice	SAP SAP
80	3,1 - 4,3	2,2	20	12	0°		Casadei	LI25M31AA3	F03FS02606
80	3,1 - 4,3	2,2	22	12	0°			LI25M31AB3	F03FS02608
100	3,1 - 4,3	2,5	20	20	0°			LI25M31BC3	F03FS06099
100	3,1 - 4,3	2,2	20	24	0°		Schelling	LI25M31BA3	F03FS02610
100	3,1 - 4,3	2,2	22	24	0°			LI25M31BB3	F03FS02612
110	3,1 - 4,3	2,2	20	24	0°			LI25M31CA3	F03FS02614
110	3,1 - 4,3	2,2	22	24	0°			LI25M31CB3	F03FS02615
115	3,1 - 4,3	2,2	20	24	0°			LI25M31DA3	F03FS02616
115	3,1 - 4,3	2,2	22	24	0°			LI25M31DB3	F03FS02618
120	2,8 - 4,0	2,2	20	24	0°		Schelling	LI25M28EA3	F03FS02604
120	2,8 - 4,0	2,2	22	24	0°			LI25M28EB3	F03FS02605
120	3,1 - 4,3	2,2	20	24	0°			LI25M31EA3	F03FS02620
120	3,1 - 4,3	2,2	22	24	0°			LI25M31EB3	F03FS02622
120	3,1 - 4,3	2,5	20	24	0°			LI25M31EC3	F03FS05978
120	3,4 - 4,6	2,2	20	24	0°		SCM	LI25M34EA3	F03FS02632
125	3,1 - 4,3	2,2	20	24	0°		Panhans-Schelling	LI25M31FA3	F03FS02623
125	3,1 - 4,3	2,2	22	24	0°		Martin	LI25M31FB3	F03FS02625
125	3,1 - 4,3	2,5	20	24	0°		Panhans-Schelling	LI25M31FC3	F03FS05932
125	3,4 - 4,6	2,2	20	24	0°			LI25M34FA3	F03FS02634
125	3,4 - 4,6	2,2	45	24	0°			LI25M34FE3	F03FS02636
125	4,3 - 5,5	3,2	20	24	0°		Panhans - Gabbiani	LI25M43FA3	F03FS02643
125	4,3 - 5,5	3,2	45	24	0°		Giben - Homag	LI25M43FE3	F03FS02645
125	4,5 - 5,7	3,0	20	24	0°			LI25M45FA3	F03FS02697
125	4,5 - 5,7	3,0	45	24	0°		Giben - Homag	LI25M45FE3	F03FS02699
140	3,1 - 4,3	2,2	16	28	8°	1/6/33	Scheer	LI25M31HM3	F03FS02627
140	3,4 - 4,7	3,0	45	24	8°			LI25M34HE3	F03FS02638
140	4,3 - 5,5	3,2	45	28	8°		Euromac	LI25M43HE3	F03FS02647
140	4,5 - 5,7	3,0	45	24	8°			LI25M45HE3	F03FS02701
150	3,1 - 4,3	2,2	30	36	8°		SCM	LI25M31KC3	F03FS02628
150	3,4 - 4,7	2,2	30	36	8°		SCM	LI25M34KC3	F03FS02639
150	4,3 - 5,6	3,2	30	36	8°		SCM	LI25M43KC3	F03FS02649
150	4,3 - 5,6	3,2	45	36	8°		SCM	LI25M43KE3	F03FS02651
150	4,5 - 5,8	3,0	30	36	8°		SCM	LI25M45KC3	F03FS02702
150	4,5 - 5,8	3,0	45	36	8°		SCM	LI25M45KE3	F03FS02704
160	3,1 - 4,3	2,2	20	36	8°		Langzauner	LI25M31LA3	F03FS02630
160	3,4 - 4,6	2,2	25,4	36	8°			LI25M34LR3	F03FS02641
160	4,3 - 5,5	3,2	25,4	36	8°			LI25M43LR3	F03FS02660
160	4,3 - 5,5	3,2	30	36	8°		Langzauner	LI25M43LC3	F03FS02653
160	4,3 - 5,5	3,2	45	36	8°	3/11/70	Giben	LI25M43LE3	F03FS02655
160	4,3 - 5,5	3,2	55	36	8°	3/6/84 + 3/7/66	Gabbiani - SCM	LI25M43LG3	F03FS02657
160	4,3 - 5,5	3,2	60	36	8°	3/7/80		LI25M43LH3	F03FS02659
160	4,5 - 5,7	3,0	45	36	8°	3/11/70	Giben	LI25M45LE3	F03FS02706

D mm	B - B1 mm	b mm	d mm	Z	$\alpha$	NL FT	Machines Macchine	Code Codice	SAP SAP
160	4,5 - 5,7	3,0	55	36	8°	3/7/66 + 3/9/72	Gabbiani	LI25M45LG3	F03FS02708
160	5,1 - 6,3	3,5	60	36	8°	3/7/80		LI25M51LH3	F03FS02723
180	3,1 - 4,3	2,2	16	42	8°	1/6/33	Scheer	LI25M31NM3	F03FS02631
180	3,4 - 4,6	2,2	25,4	36	8°			LI25M34NR3	F03FS02642
180	4,3 - 5,5	3,2	20	28	8°		Schelling - Anthon	LI25M43NA3	F03FS02661
180	4,3 - 5,5	3,2	30	28	8°	2/7/42 + 2/10/60	Panhans - Holzer	LI25M43NC3	F03FS02663
180	4,3 - 5,5	3,2	20	36	8°		Schelling - Anthon	LI25M43XA3	F03FS06372
180	4,3 - 5,5	3,2	30	36	8°	2/7/42 + 2/10/60	Panhans	LI25M43XN3	F03FS06373
180	4,3 - 5,5	3,2	45	36	8°		Holzma	LI25M43NE3	F03FS02664
180	4,3 - 5,5	3,2	50	36	8°	3/13/80	Giben	LI25M43NF3	F03FS02666
180	4,5 - 5,7	3,0	20	36	8°		Schelling - Anthon	LI25M45NA3	F03FS02710
180	4,7 - 5,9	3,5	45	36	8°		Holzma	LI25M47NE3	F03FS02715
180	5,1 - 6,3	3,5	55	36	8°	3/7/66	Gabbiani	LI25M51NG3	F03FS02724
180	5,7 - 6,9	4,0	20	36	8°		Holzma	LI25M57NA3	F03FS02727
200	4,3 - 5,5	3,2	20	36	8°		Schelling	LI25M43PA3	F03FS02670
200	4,3 - 5,5	3,2	22	36	8°			LI25M43PB3	F03FS02673
200	4,3 - 5,5	3,2	30	36	8°	2/9/60	Scheer	LI25M43PC3	F03FS02674
200	4,3 - 5,5	3,2	45	36	8°		Holzma	LI25M43PE3	F03FS02676
200	4,3 - 5,5	3,2	50	36	8°	3/13/80	Giben Smart	LI25M43PF3	F03FS02679
200	4,3 - 5,5	3,2	65	36	8°	2/9/100 + 2/9/110	Selco	LI25M43PI3	F03FS02681
200	4,3 - 5,5	3,2	80	36	8°	2/14/110	Gabbiani	LI25M43PL3	F03FS02683
200	4,5 - 5,7	3,0	22	36	8°			LI25M45PB3	F03FS02712
200	4,5 - 5,7	3,0	65	36	8°	2/8,5/110	Selco	LI25M45PI3	F03FS02714
200	4,7 - 5,9	3,5	20	36	8°			LI25M47PA3	F03FS02716
200	4,7 - 5,9	3,5	22	36	8°			LI25M47PB3	F03FS02717
200	4,7 - 5,9	3,5	30	36	8°	2/9/60	Scheer	LI25M47PC3	F03FS02718
200	4,7 - 5,9	3,5	45	36	8°		Holzma	LI25M47PE3	F03FS02719
200	4,7 - 5,9	3,5	65	36	8°	2/9/100 + 2/9/110	Selco	LI25M47PI3	F03FS02720
200	5,1 - 6,3	3,5	20	36	8°		Schelling	LI25M51PA3	F03FS02725
200	5,4 - 6,6	3,8	20	36	8°			LI25M54PA3	F03FS02726
200	5,7 - 6,9	4,0	45	36	8°		Holzma	LI25M57PE3	F03FS02728
200	6,1 - 7,3	4,2	20	36	8°		Schelling	LI25M61PA3	F03FS02730
200	6,1 - 7,3	4,2	45	36	8°		Holzma	LI25M61PE3	F03FS02731
215	4,3 - 5,5	3,2	50	42	8°	2/7/80 + 3/15/80	Giben	LI25M43QF3	F03FS02685
215	4,5 - 5,7	3,2	50	42	8°	3/15/80	Giben	LI25M45PF3	F03FS02713
220	6,3 - 7,5	4,4	20	36	8°		Schelling	LI25M63UA3	F03FS02732
250	4,3 - 5,5	3,2	50	48	6°	3/13/80	Selco	LI25M430F3	
250	4,3 - 5,5	3,2	30	48	8°	2/10/60 ORIZZONTALI		LI25M430C3	F03FS02668
280	4,3 - 5,5	3,2	30	48	6°	2/10/60 ORIZZONTALI	Panhans	LI25M43VC3	
300	4,3 - 5,5	3,0	65	48	6°	2/8.4/100 + 2/8.4/110	Selco	LI25M43RX3	
300	4,3 - 5,5	3,2	30	48	6°	2/11/75	Schelling	LI25M43RC3	
300	4,3 - 5,5	3,5	50	48	12°	3/15/80	Giben	LI25M43RM3	F03FS02693
300	4,3 - 5,5	3,2	65	72	12°	2/9/110	Selco	LI25M43RI3	F03FS02689
300	4,3 - 5,5	3,2	80	72	12°	2/14/110		LI25M43RL3	F03FS02691
300	4,7 - 5,9	3,5	65	48	6°	2/9/110	Selco	LI25M47RX3	
320	4,3 - 5,5	3,0	45	48	12°			LI25M43SE3	F03FS02696
320	4,3 - 5,5	3,2	45	48	12°			LI25M43SA3	F03FS02695
340	4,7 - 5,9	3,5	45	72	12°	3/14/65	Holzma	LI25M47TE3	F03FS02722

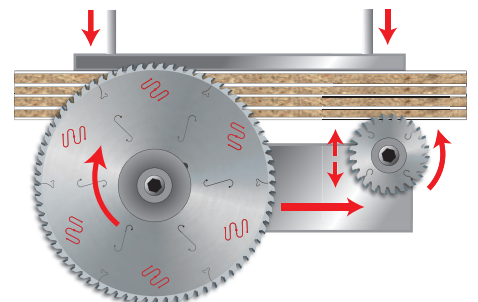
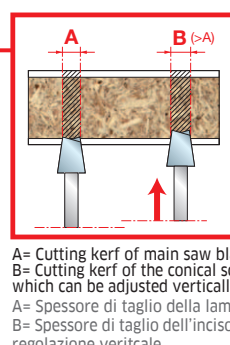
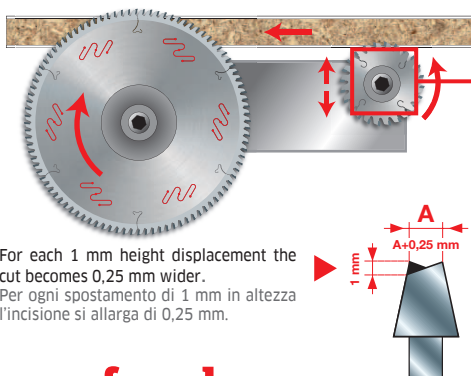

# LI16M

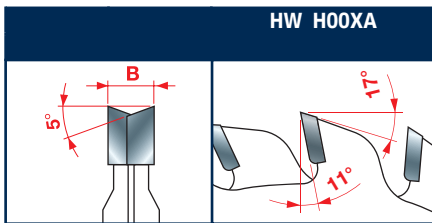

Tooth features - Caratteristiche del dente

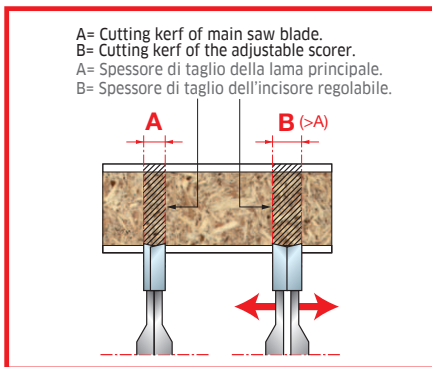

## HW - Adjustable scoring saw blades HW - Lama incisore regolabili

To score the coating on bilaminated panels.

**Machines:** Horizontal panel sizing machines that do not allow the adjustment of the scoring depth. Max scoring depth 2 mm.

**Features:** ATB tooth 5° with positive cutting angle.

**Material:** Bilaminated chipboard or MDF.

Per l'incisione del rivestimento di pannelli bilaminati.

**Macchine:** Sezionatrici orizzontali con l'albero dell'incisore fisso. Profondità max di incisione 2 mm.

**Caratteristiche:** Dentatura alterna a 5° con angolo di taglio positivo.

**Materiale:** Pannelli in truciolare o MDF bilaminati.

D mm	B mm	d mm	Z	Machines Macchine	Code Codice	SAP SAP
80	2,8-3,6	20	10+10	Robland	<b>LI16M HA3</b>	F03FS02502
80	2,8-3,6	20	12+12	Felder	<b>LI16M GA3</b>	F03FS02501
100	2,8-3,6	20	12+12	Schelling - Panhans - Martin	<b>LI16M BA3</b>	F03FS02491
100	2,8-3,6	22	12+12	Altendorf - Striebig - Panhans	<b>LI16M BB3</b>	F03FS02493
100	2,8-3,6	25,4	12+12	Baldan	<b>LI16M BR3</b>	F03FS07433
105	2,8-3,6	20	10+10		<b>LI16M CA3</b>	F03FS02495
120	2,8-3,6	20	12+12	Holzher - SCM	<b>LI16M AA3</b>	F03FS02485
120	2,8-3,6	22	12+12	Altendorf - Martin - Mrozek	<b>LI16M AB3</b>	F03FS02488
120	2,8-3,6	50	12+12	Altendorf - Griggio	<b>LI16M PF3*</b>	F03FS02512
120	2,8-3,6	50	12+12	Felder	<b>LI16M RF3*</b>	F03FS06512
120	4,0-5,0	50	12+12		<b>LI16M IF3*</b>	F03FS02504
125	2,8-3,6	20	12+12	Paoloni	<b>LI16M FA3</b>	F03FS02500
125	2,8-3,6	20	14+14		<b>LI16M EA3</b>	F03FS02498
125	2,8-3,6	22	14+14		<b>LI16M EB3</b>	F03FS02499
125	4,0-4,7	20	20+20	SCM	<b>LI16M DA3</b>	F03FS02496
125	4,0-5,0	45	12+12	Giben - Mayer	<b>LI16M KE3</b>	F03FS02506
160	4,0-5,2	60	20+20		<b>LI16M IH3</b>	F03FS02505
180	2,8-3,6	30	20+20	Kolle	<b>LI16M LC3</b>	F03FS02508
180	4,0-5,0	20	20+20	Schelling	<b>LI16M MA3</b>	F03FS02509
180	4,4-5,6	45	20+20	Holzma	<b>LI16M NE3</b>	F03FS02510
200	4,0-5,2	50	28+28	Giben	<b>LI16M OF3</b>	F03FS02511

\* Thickness adjustment controlled by the machines, no spacers required.

\* La regolazione dello spessore viene fatta in macchina, senza l'uso di anelli distanziali.

# LI27M

## HW - Postforming scoring saw blades HW - Lama incisore postforming

To score the coating on bilaminated panels.

**Machines:** Horizontal panel sizing machines.

**Features:** ATB tooth with positive cutting angle.

**Material:** Bilaminated chipboard or MDF.

Per l'incisione del rivestimento di pannelli bilaminati.

**Macchine:** Sezionatrici orizzontali.

**Caratteristiche:** Dentatura alterna con angolo di taglio positivo.

**Materiale:** Pannelli in truciolare o MDF bilaminati.

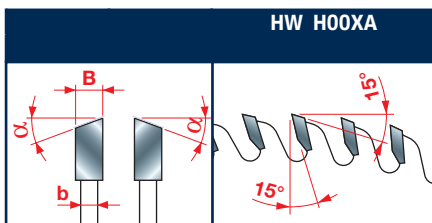

Tooth features - Caratteristiche del dente

D mm	B mm	b mm	d mm	Z	$\alpha$	NL FT	Code Codice	SAP SAP
200	4,7	3,5	80	42	10°	2/14/110	LI27M FA3	F03FS02749
220	3,4	2,2	30	48	10°		LI27M AA3	F03FS02733
250	4,6	3,0	30	48	10°		LI27M BA3	F03FS02734
280	5,0	3,5	45	84	30°		LI27M CA3	F03FS02736
300	4,55	3,0	30	72	10°		LI27M DF3	F03FS02745
300	4,55	3,2	65	72	10°	2/9/100+2/9/110	LI27M DA3	F03FS02737
300	4,55	3,2	50	72	10°	3/15/80	LI27M DD3	F03FS02743
300	4,7	3,2	80	72	10°	2/14/110	LI27M DC3	F03FS02741
300	4,95	3,0	65	72	10°	2/9/100+2/9/110	LI27M DB3	F03FS02739
340	5,0	3,5	45	48	30°	3/14/65	LI27M EA3	F03FS02746
340	5,0	3,5	45	108	30°	3/14/65	LI27M EB3	F03FS02747

# LI20M

## HW - Flat tooth scoring saw blades HW - Lama incisore con dente piano

To score bilaminated panels with plastic coating.

**Machines:** Horizontal panel sizing machines.

**Features:** Flat tooth with positive cutting angle.

**Material:** Bilaminated chipboard or MDF.

Per l'incisione del rivestimento di pannelli ricoperti di laminato plastico.

**Macchine:** Sezionatrici orizzontali.

**Caratteristiche:** Dentatura piana con angolo di taglio positivo.

**Materiale:** Pannelli in truciolare o MDF bilaminati.

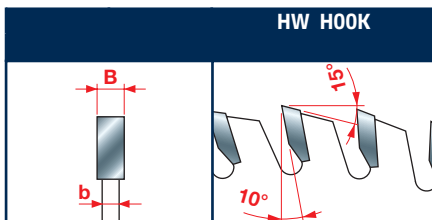

Tooth features - Caratteristiche del dente

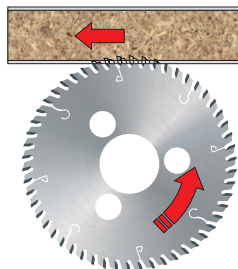

D mm	B mm	b mm	d mm	Z	NL FT	Code Codice	SAP SAP
180	3,2	2,2	50	54	3/22/80	LI20M BB3	F03FS02579

# LI17M

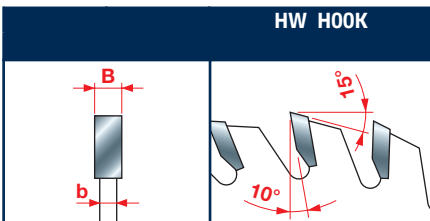

Tooth features - Caratteristiche del dente

# LI22MD - LI22MS

Right  
Destra

Left  
Sinistra

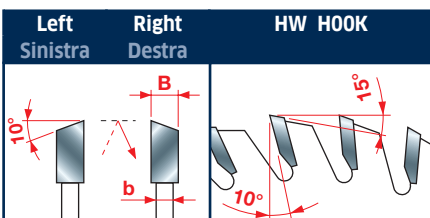

Tooth features - Caratteristiche del dente

## HW - Flat tooth scoring saw blades HW - Lama incisore con dente piano

To score the coating on bilaminated panels.

**Machines:** SCM Horizontal panel sizing machines.

**Features:** Flat tooth with positive cutting angle.

**Material:** Bilaminated chipboard or MDF.

Per l'incisione del rivestimento di pannelli bilaminati.

**Macchine:** Sezionatrici orizzontali SCM.

**Caratteristiche:** Dentatura piana con angolo di taglio positivo.

**Materiale:** Pannelli in truciolare o MDF bilaminati.

D mm	B mm	b mm	d mm	Z	NL FT	Code Codice	SAP SAP
115	3,2	2,2	20	30		LI17M FA3	F03FS02572
120	3,2	2,2	20	30		LI17M GA3	F03FS02574

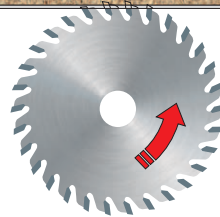

## HW - Bevelled tooth scoring saw blades HW - Lama incisore con dente inclinato

To score bilaminated panels with plastic or thermohardened resins coating.

**Machines:** Horizontal panel sizing machines.

**Features:** Bevelled tothing with positive cutting angle.

**Material:** Bilaminated chipboard or MDF.

Per l'incisione del rivestimento di pannelli ricoperti in laminato plastico o resina termoindurente.

**Macchine:** Sezionatrici orizzontali.

**Caratteristiche:** Dentatura unilateralmente inclinata con angolo di taglio positivo.

**Materiale:** Pannelli in truciolare o MDF bilaminati.

D mm	B mm	b mm	d mm	Z	NL FT	Code Codice	SAP SAP	Code Codice	SAP SAP
						Right - Dx	Right - Dx	Left - Sx	Left - Sx
150	3,2	2,2	30	36		LI22MD KC3	F03FS02581	LI22MS KC3	F03FS02592
150	3,2	2,2	55	36		LI22MD KG3	F03FS02583	LI22MS KG3	F03FS02594
150	3,2	2,2	60	36		LI22MD KH3	F03FS02584	LI22MS KH3	F03FS02595
180	3,2	2,2	30	42		LI22MD NC3	F03FS02585	LI22MS NC3	F03FS02596
180	3,2	2,2	55	42		LI22MD NG3	F03FS02586	LI22MS NG3	F03FS02598
200	3,2	2,2	30	48		LI22MD PC3	F03FS02589	LI22MS PC3	F03FS02601
200	3,2	2,2	60	48		LI22MD PH3	F03FS02590	LI22MS PH3	F03FS02602

# LI13MD - LI13MS

Right  
Destra

Left  
Sinistra

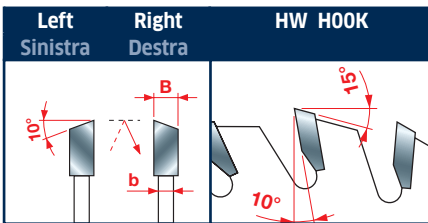

Tooth features - Caratteristiche del dente

# LI14MD - LI14MS

Right  
Destra

Left  
Sinistra

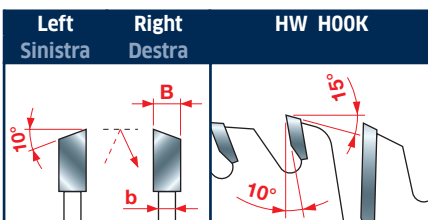

Tooth features - Caratteristiche del dente

## HW - Bevelled tooth scoring saw blades HW - Lama incisore con dente inclinato

To score bilaminated panels with very fragile plastic coating.  
**Machines:** Panel sizing machines, double-end tenoners, edge benders.  
**Features:** Bevelled toothing with positive cutting angle.  
**Material:** Bilaminated chipboard or MDF.

Per l'incisione del rivestimento di pannelli ricoperti in laminato molto fragile.  
**Macchine:** Sezionatrici, squadratrici e bordatrici.  
**Caratteristiche:** Dentatura unilateralmente inclinata con angolo di taglio positivo.  
**Materiale:** Pannelli in truciolare o MDF bilaminati.

D mm	B mm	b mm	d mm	Z	NL FT	Code Codice Right - Dx	SAP SAP Right - Dx	Code Codice Left - Sx	SAP SAP Left - Sx
100	3,2	2,2	20	24		LI13MD AA3	F03FS02452	LI13MS AA3	F03FS02466
100	3,2	2,2	22	24		LI13MD AB3	F03FS02454	LI13MS AB3	F03FS02468
125	3,2	2,2	20	30		LI13MD BA3	F03FS02455	LI13MS BA3	F03FS02470
150	3,2	2,2	30	48		LI13MD DA3	F03FS02459	LI13MS DA3	F03FS02474
150	3,2	2,2	55	48		LI13MD DB3	F03FS02461	LI13MS DB3	F03FS02476

## HW - End trim unit for panels with bended edges HW - Lama incisore-intestatore per pannelli bordati

For cutting and boarding panels with bended edges.  
**Machines:** Edge benders.  
**Features:** Bevelled toothing with 4 rakers with positive cutting angle.  
**Material:** Bilaminated chipboard or MDF.

Per la squadratura e l'intestatura di pannelli bordati.  
**Macchine:** Bordatrici.  
**Caratteristiche:** Dentatura unilateralmente inclinata con angolo di taglio positivo e 4 rasanti.  
**Materiale:** Pannelli in truciolare o MDF bilaminati.

D mm	B mm	b mm	d mm	Z	NL FT	Code Codice Right - Dx	SAP SAP Right - Dx	Code Codice Left - Sx	SAP SAP Left - Sx
140	3,2	2,2	30	28+4		LI14MD CA3	F03FS02476	LI14MS CA3	F03FS02483

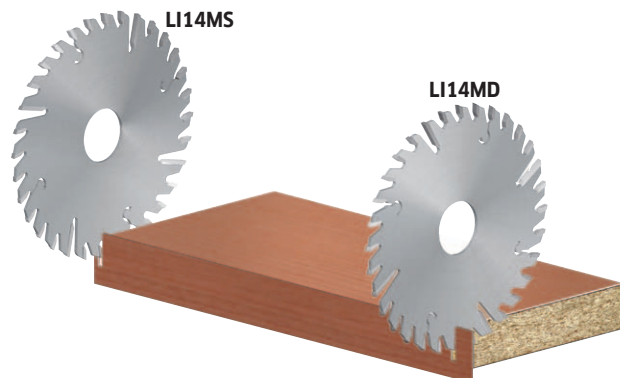

# LT16MD - LT16MS

Right  
Destra

Left  
Sinistra

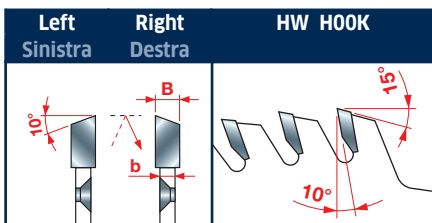

Tooth features - Caratteristiche del dente

# LT12MD - LT12MS

Right  
Destra

Left  
Sinistra

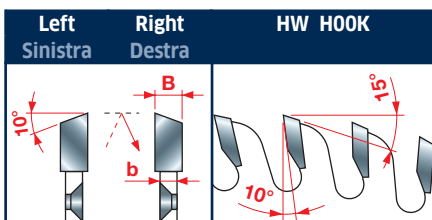

Tooth features - Caratteristiche del dente

## HW - Saw blades for freud hogging units HW - Lame per truciolatori freud

Saw blades suitable for squaring and trimming panels.

**Machines:** Single-side or double-end tenoners and squaring edgebanding machines.

**Features:** Right or left bevel tooth with positive cutting angle.

**Material:** Bilaminated panels.

Lame per la squadratura e rifilatura di pannelli.

**Macchine:** Squadratrici singole o doppie e squadra-bordatrici.

**Caratteristiche:** Dentatura unilateralmente inclinata con angolo di taglio positivo.

**Materiale:** Pannelli bilaminati.

D	B	b	d	Z	NL	Code	SAP	Code	SAP
mm	mm	mm	mm		FT	Codice	SAP	Codice	SAP
						Right - Dx	Right - Dx	Left - Sx	Left - Sx
250	4,2	3,0	130	56	10/8,5/170	LT16MD BD3	F03FS04401	LT16MS BD3	F03FS04409
300	4,2	3,0	130	68	10/8,5/215	LT16MD CD3	F03FS04404	LT16MS CD3	F03FS04412

## HW - Saw blades for hogging units HW - Lame per truciolatori

Saw blades suitable for squaring and trimming panels.

**Machines:** Single-side or double-end tenoners and squaring edgebanding machines.

**Features:** Right or left bevel tooth with positive cutting angle.

**Material:** Bilaminated panels.

Lame per la squadratura e rifilatura di pannelli.

**Macchine:** Squadratrici singole o doppie e squadra\_bordatrici.

**Caratteristiche:** Dentatura unilateralmente inclinata con angolo di taglio positivo.

**Materiale:** Pannelli bilaminati.

D	B	b	d	Z	NL	Code	SAP	Code	SAP
mm	mm	mm	mm		FT	Codice	SAP	Codice	SAP
						Right - Dx	Right - Dx	Left - Sx	Left - Sx
250	4,2	3,0	130	60	4/8,5/185	LT12MD BB3	F03FS06324	LT12MS BB3	F03FS07063

# LT14MD - LT14MS

Right  
Destra

Left  
Sinistra

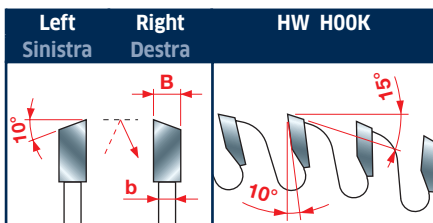
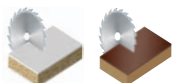

Tooth features - Caratteristiche del dente

# LT18MD - LT18MS

Right  
Destra

Left  
Sinistra

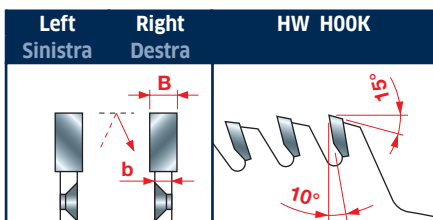
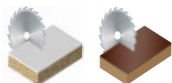
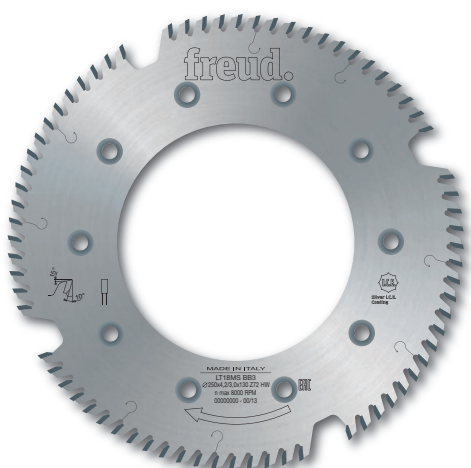

Tooth features - Caratteristiche del dente

## HW - Saw blades for hogging units (customized) HW - Lama per truciolatori (esecuzione speciale)

Saw blades suitable for squaring and trimming panels.

**Machines:** Single-side or double-end tenoners and squaring edgebanding machines.

**Features:** Right or left bevel tooth with positive cutting angle.

**Material:** Bilaminated panels.

Lame per la squadratura e rifilatura di pannelli.

**Macchine:** Squadratrici singole o doppie e squadra-bordatrici.

**Caratteristiche:** Dentatura unilateralmente inclinata con angolo di taglio positivo.

**Materiale:** Pannelli bilaminati.

D	B	b	d	Z	NL	Code	SAP	Code	SAP
mm	mm	mm	mm		FT	Codice	SAP	Codice	SAP
						Right - Dx	Right - Dx	Left - Sx	Left - Sx
200	4,2	3,0	30	48	*	LT14MD AA3	F03FS04378	LT14MS AA3	F03FS04389
250	4,2	3,0	30	60	*	LT14MD BA3	F03FS04380	LT14MS BA3	F03FS04391
250	4,2	3,0	130	60	*	LT14MD BB3	F03FS04382	LT14MS BB3	F03FS04393
255	4,2	3,0	80	60	*	LT14MD FA3	F03FS04387	LT14MS FA3	F03FS04398
350	4,2	3,0	30	84	*	LT14MD DA3	F03FS04386	LT14MS DA3	F03FS04397

### \* WHEN ORDERING, ALWAYS SPECIFY:

a) **OPT08 AA9:** for increasing bore Ø;

b) **OPTFO...:** for pin holes (NL\* - see page 87).

**Send sample sawblade or drawing with bore size, PCD and hole size (ex. OPTFO AF9 with 6 countersunk holes).**

### \* INDICARE TASSATIVAMENTE:

a) **OPT08 AA9:** per allargatura foro;

b) **OPTFO...:** per fori di fissaggio (FT\* - vedi pag 87).

**Inviare sempre una lama campione o indicare il diametro e l'interasse dei fori di fissaggio. (es. OPTFO AF9 con 6 fori svasati).**

## HW - Saw blades for freud hogging units HW - Lama per truciolatori freud

Saw blades suitable for squaring and trimming panels.

**Machines:** Single-side or double-end tenoners and squaring edgebanding machines.

**Features:** Flat tooth with positive cutting angle.

**Material:** Bilaminated panels.

Lame per la squadratura e rifilatura di pannelli.

**Macchine:** Squadratrici singole o doppie e squadra-bordatrici.

**Caratteristiche:** Dentatura piana con angolo di taglio positivo.

**Materiale:** Pannelli bilaminati.

D	B	b	d	Z	NL	Code	SAP	Code	SAP
mm	mm	mm	mm		FT	Codice	SAP	Codice	SAP
						Right - Dx	Right - Dx	Left - Sx	Left - Sx
250	4,2	3,0	130	72	10/8,5/170	LT18MD BB3	F03FS04415	LT18MS BB3	F03FS04417

# LT20MD - LT20MS

Right  
Destra

Left  
Sinistra



## HW - Saw blades for Leuco hogging units HW - Lama per truciolatori Leuco

Saw blades suitable for squaring and trimming panels.

**Machines:** Single-side or double-end tenoners and squaring edgebanding machines.

**Features:** Flat tooth with positive cutting angle.

**Material:** Bilaminated panels.

Lame per la squadratura e refilatura di pannelli.

**Macchine:** Squadratrici singole o doppie e squadra-bordatrici.

**Caratteristiche:** Dentatura piana con angolo di taglio positivo.

**Materiale:** Pannelli bilaminati.

D	B	b	d	Z	NL	Code	SAP	Code	SAP
mm	mm	mm	mm		FT	Codice	SAP	Codice	SAP
						Right - Dx	Right - Dx	Left - Sx	Left - Sx
250	4,0	3,0	100	72	6/7/200	LT20MD BB3	F03FS04421	LT20MS BB3	F03FS04422

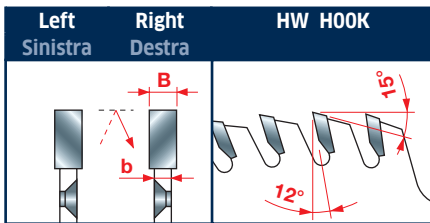
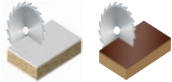

Tooth features - Caratteristiche del dente

# TR15MD - TR15MS

Right  
Destra

Left  
Sinistra

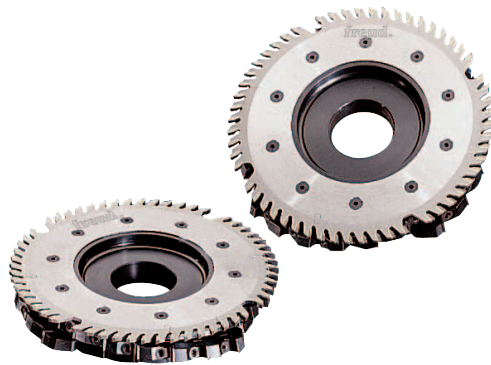
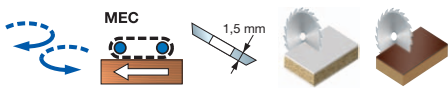
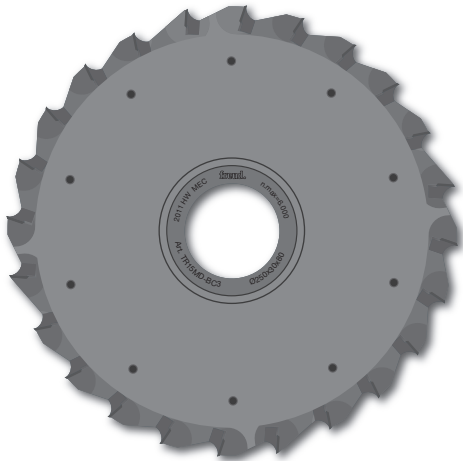

## Hogging units with HW turnover knives Truciolatori con coltelli a gettare in HW

Particularly indicated for squaring wood composites, unprocessed and covered panels.

**Machines:** Single-side or double-end tenoners.

**Features:** • Spare saw blades: LT16MD/S - LT18MD/S.

- Supplied with disposable knives fitted with double spiral disposition.
- Excellent chipping.
- Easy feed rate.

Ideale per la squadratura di pannelli composti, grezzi e rivestiti.

**Macchine:** Squadratrici singole e doppie.

**Caratteristiche:**

- Lame applicabili: LT16MD/S - LT18MD/S.
- Dotato di coltelli a gettare in HW, disposti con sviluppo elicoidale.
- Notevole truciolamento.
- Facile avanzamento.

D mm	B mm	d mm	Z	Code Codice	SAP SAP	Code Codice	SAP SAP
				Right - Dx	Right - Dx	Left - Sx	Left - Sx
250	30	60	24	<b>TR15MD BA3</b>	F03FC20547	<b>TR15MS BA3</b>	F03FC20543
250	30	80	24	<b>TR15MD BC3</b>	F03FC20548	<b>TR15MS BC3</b>	F03FC20544

Spare parts Parti di ricambio	Dimensions Dimensioni	Code Codice	SAP SAP
Knife / Coltello	12 x 12 x 1,5	<b>CG01M BA3</b>	F03FH00182
Right Wedge / Cuneo Destra	15 x 11 x 9	<b>CN09MD AG9</b>	F03FC01302
Left Wedge / Cuneo Sinistra	15 x 11 x 9	<b>CN09MS AG9</b>	F03FC01328
Screw / Vite	M6 x 22	<b>VT19M AB9</b>	F03FA04491
Nut / Ogiva	10 x 11,5 x 6	<b>VT20M AA9</b>	F03FS02590
Screw / Vite	M6 x 10	<b>VT01M AA9</b>	F03FA04429
Allen key / Chiave	3 x 110	<b>CB03M AA9</b>	F03FA00162

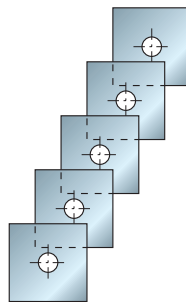

The knives are set on a spiral providing a shear cutting action. The knives can be used 8 times (4 times for the right hand rotation and 4 times for the left hand rotation).

I coltelli sono disposti seguendo un allineamento elicoidale e si possono utilizzare 8 volte (4 volte a destra + 4 volte a sinistra).



# MT01M

## Mounting sleeves for hogging units Mozi per truciolatori

Item MT01M includes the fixing operation of the mounting sleeve to the hogging unit.

**Note: The fixing must be done in our factory and only on Freud's hogs. This mounting sleeve works only with the hogging units item TR15M and must be ordered separately.**

Il codice MT01M include l'operazione di fissaggio al truciolatore.

**N.B.:** L'accoppiamento deve essere eseguito in sede e solo con truciolatori Freud. Questo mozzo viene utilizzato esclusivamente con truciolatori TR15M e deve essere ordinato a parte.

d mm	KN CH	Code Codice	SAP SAP
35	10 x 4	<b>MT01M AA9</b>	F03FC15424
40	10 x 4	<b>MT01M BA9</b>	F03FC15424

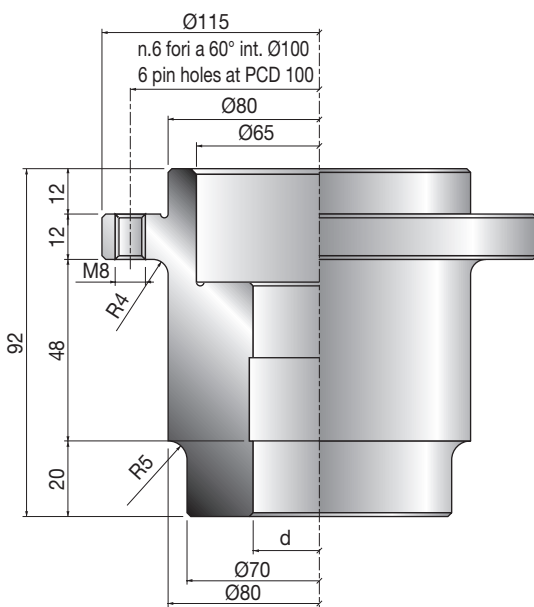

# TR16MD - TR16MS

Right  
Destra

Left  
Sinistra

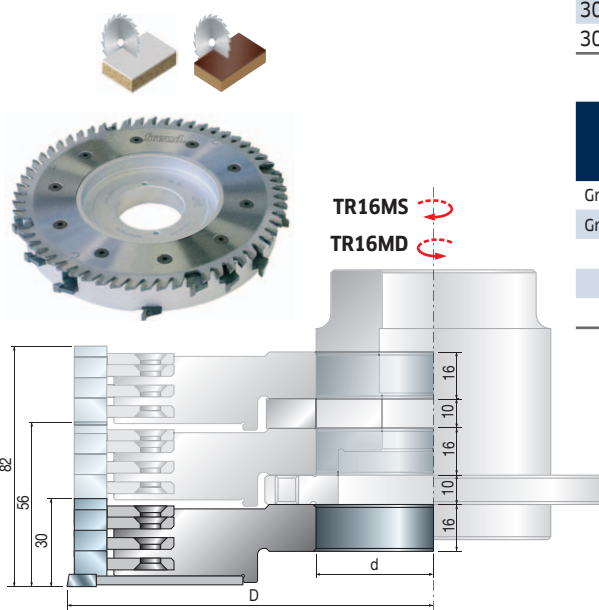
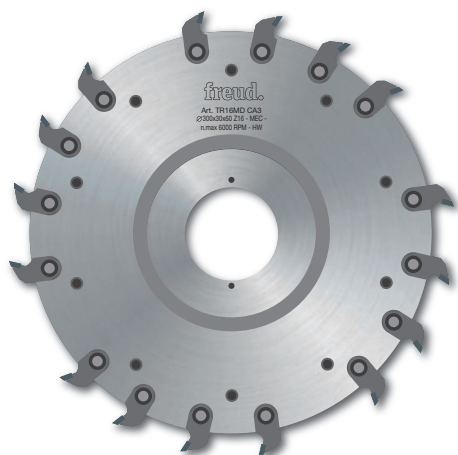

## Hogging units with SR06M interchangeable inserts Truciolatori con inserti intercambiabili SR06M

Particularly indicated for squaring solid wood panels.

**Machines:** Single-side or double-end tenoners.

**Features:**

- Spare saw blades: LT16MD/S - LT18MDS.

- Supplied with resharpenable inserts fitted with 2 spiral disposition.
- Excellent chipping.
- Easy feed rate.

Ideale per la squadratura di pannelli in legno massiccio.

**Macchine:** Squadratrici singole e doppie.

**Caratteristiche:**

- Lame applicabili LT16MD/S - LT18MD/S.
- Dotato di inserti riaffilabili in HW, disposti con sviluppo elicoidale.
- Notevole truciolamento.
- Facile avanzamento.

\* Nominal saw blade diameter. / \* Diametro nominale della lama.

D*	B	d	Z	Code	SAP	Code	SAP
				Codice	SAP	Codice	SAP
				Right - Dx	Right - Dx	Left - Sx	Left - Sx
200	30	80	16	<b>TR16MD AA3</b>	F03FC20547	<b>TR16MS AA3</b>	F03FC20550
250	30	60	16	<b>TR16MD BA3</b>	F03FC20548	<b>TR16MS BA3</b>	F03FC20551
250	30	80	16	<b>TR16MD BB3</b>	F03FC22094	<b>TR16MS BB3</b>	F03FC22096
300	30	60	16	<b>TR16MD CA3</b>	F03FC20549	<b>TR16MS CA3</b>	F03FC20552
300	30	80	16	<b>TR16MD CB3</b>	F03FC22095	<b>TR16MS CB3</b>	F03FC22097

Spare parts Parti di ricambio	Dimensions Dimensioni	Code Codice	SAP SAP
Grooving inserts / Inserti per incastri	34 x 9 x 16	<b>SR06MD BB3</b>	F03FC18933
Grooving inserts / Inserti per incastri	34 x 9 x 16	<b>SR06MS BB3</b>	F03FC18936
Screw / Vite	M6 x 11, 5	<b>VT16M AB9</b>	F03FA04477
Screw / Vite	M6 x 10	<b>VT01M AA9</b>	F03FA04429
Allen key / Chiave	4 x 110	<b>CB03M BA9</b>	F03FA00163

These tools can be stacked and used in multiples thus enabling the machining of a wider area.

Questi utensili possono essere sovrapposti e utilizzati insieme per la lavorazione di una superficie più ampia.

# MT01M

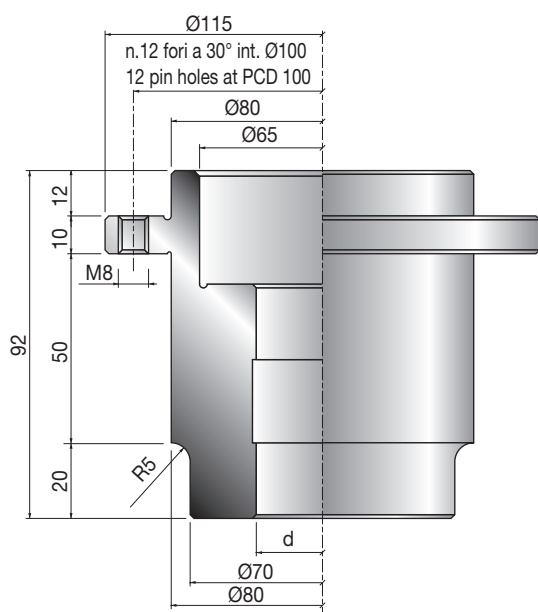

## Mounting sleeves for hogging units Mozzi per truciolatori

Item MT01M includes the fixing operation of the mounting sleeve to the hogging unit.

**Note: The fixing must be done in our factory and only on freud's hogsers. This mounting sleeve works only with the hogging units item TR16M and must be ordered separately.**

Il codice MT01M include l'operazione di fissaggio al truciolatore.

**N.B.:** L'accoppiamento deve essere eseguito in sede e solo con truciolatori freud. Questo mozzo viene utilizzato esclusivamente con truciolatori TR16M e deve essere ordinato a parte.

d	KN	Code	SAP
mm	CH	Codice	SAP
35	10 x 4	<b>MT01M DA9</b>	F03FC15424

# LU4A

## HW - Saw blades to cut plastic materials HW - Lame per il taglio di materiali plastici

Blades with negative wood stain that is suitable to cut plastic materials. In order to cut in a correct way, the saw blade has to stick out approximately 30 mm over the material to be cut.

**Machines:** Circular saws, portable machines.

**Features:** Flat-triple chip tooth with negative cutting angle. The specific size of the teeth allows cutting with perfect finishing, without melting and scratching the material.

**Material:** Plastic materials, plexiglas.

Lame con mordente negativo adatto per il taglio di materiali plastici. Per un taglio corretto la lama deve sporgere di circa 30 mm sul materiale da tagliare.

**Macchine:** Seghe circolari, macchine portatili.

**Caratteristiche:** Piano-trapezoidale con angolo di taglio negativo. Le particolari dimensioni dei denti permettono un taglio con perfetta finitura senza fusione e senza rigatura del materiale.

**Materiale:** Materiale plastico, plexiglas.

**FT01:** 2/7/42 + 2/9/46,4 + 2/10/60

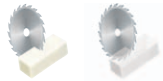
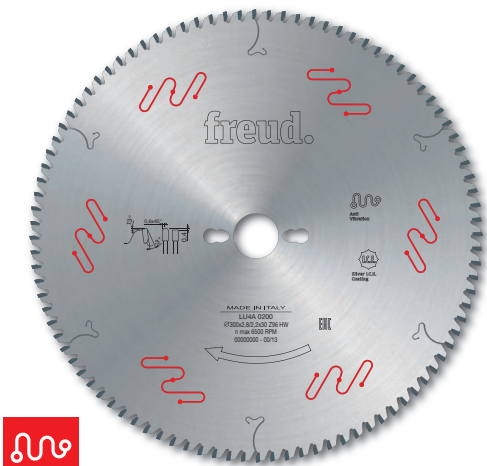

D mm	B mm	b mm	d mm	Z	NL FT	Code Codice	SAP SAP
250	2,8	2,2	30	80	FT01	<b>LU4A 0100</b>	F03FS05163
300	2,8	2,2	30	96	FT01	<b>LU4A 0200</b>	F03FS05165

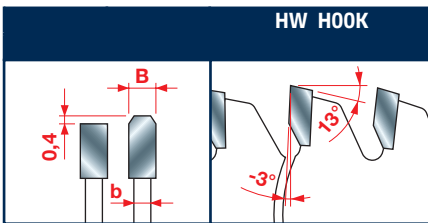

Tooth features - Caratteristiche del dente

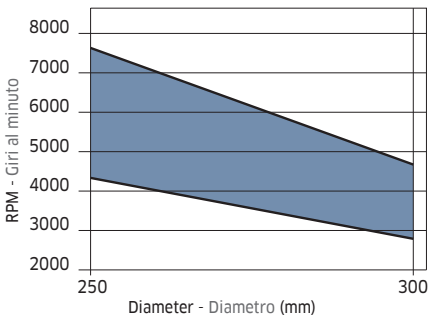

Minimum and maximum RPM based on the blade diameter.  
Fascia del N. giri minimo e massimo consigliati in funzione del diametro della lama.

	Ultimate Eccellente	High Ottimo	Good Buono
Plexiglas Plexiglas	●		
Plastic materials Materiali plastici	●		

# LU4B

## HW - Saw blades to cut plastic materials and plexiglas - thin kerf

### HW - Lame per il taglio di plastica e plexiglas - sp. sottile

To size plexiglas and plastic material panels. The reduced cutting height makes workpiece feeding easier and optimises its employment in low-power machines.

**Machines:** Circular saws, portable machines.

**Features:** Flat-ATB 10° tooth with 5° shear angle and positive cutting angle. The specific shape of the tooth ensures an excellent finishing and cutting life.

**Material:** Plastic materials, plexiglas.

Per la sezionatura in singolo di pannelli in materiale plastico e plexiglas. Lo spessore di taglio ridotto facilita l'avanzamento del pezzo da lavorare e ottimizza l'impiego su macchine a bassa potenza.

**Macchine:** Seghe circolari, macchine portatili.

**Caratteristiche:** Dentatura piano-alterna a 10°, con assiale a 5° e angolo di taglio positivo. La particolare forma del dente garantisce un'ottima finitura e durata di taglio.

**Materiale:** Materiale plastico, plexiglas.

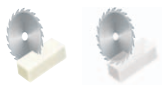

**FT01:** 2/7/42 + 2/9/46,4 + 2/10/60

D mm	B mm	b mm	d mm	Z	NL FT	Code Codice	SAP SAP
178	1,5	1,0	25,4	80		LU4B 0500	F03FS05173
203	2,0	1,4	25,4	90		LU4B 0100	F03FS05167
230	2,2	1,6	25,4	100		LU4B 0200	F03FS05169
250	2,2	1,6	30	100	FT01	LU4B 0300	F03FS05170
255	2,2	1,6	25,4	100		LU4B 0400	F03FS05172

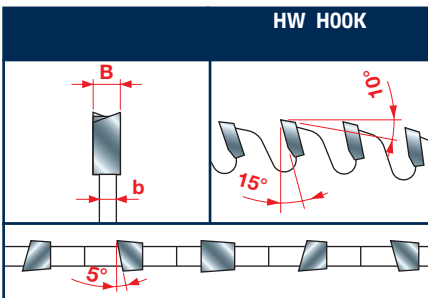

Tooth features - Caratteristiche del dente

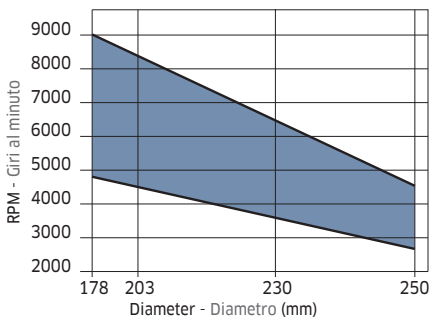

Minimum and maximum RPM based on the blade diameter.

Fascia del N. giri minimo e massimo consigliati in funzione del diametro della lama.

	Ultimate Eccellente	High Ottimo	Good Buono
Plexiglas Plexiglas	●		
Plastic materials Materiali plastici	●		

# LU4D

## HW - Saw blades to cut solid surfaces HW - Lame per il taglio di materiali polimerici

Saw blades optimized to cut solid surfaces boards.

**Machines:** Sliding table saws, miter saws.

**Features:** The special DOUBLE TRIPLE CHIP tip grind and the thickness of the plate allow to get the best quality of cut in solid surfaces application. Moreover, they guarantee a longer lifetime versus standard products, despite the highly abrasive material.

**Material:** Solid surfaces, Corian® boards and similar materials.

Lame ottimizzate per il taglio di pannelli in materiali polimerici.

**Macchine:** Seghe circolari, troncatrici.

**Caratteristiche:** La dentatura DOPPIO TRIPLE CHIP e lo spessore del corpo aumentato offrono le migliori performance di finitura nella lavorazione dei materiali polimerici, garantiscono inoltre una maggiore durata della lama, nonostante l'elevata abrasività del materiale da lavorare.

**Materiale:** Pannelli in materiali polimerici, Corian® e materiali simili.

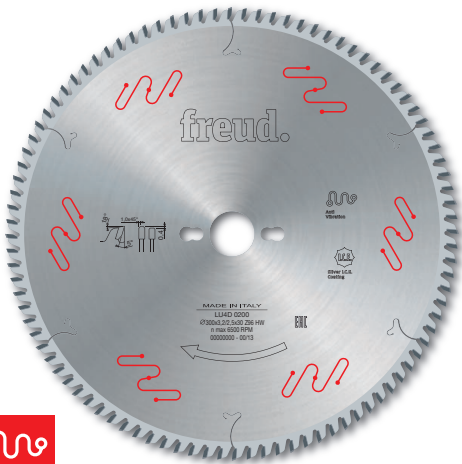

	D	B	b	d	Z	NL	Code	SAP
	mm	mm	mm	mm		FT	Codice	SAP
	250	3,2	2,5	30	80		<b>LU4D 0100</b>	F03FS07294
	300	3,2	2,5	30	96		<b>LU4D 0200</b>	F03FS07295
	350	3,5	2,80	30	108		<b>LU4D 0300</b>	F03FS07296

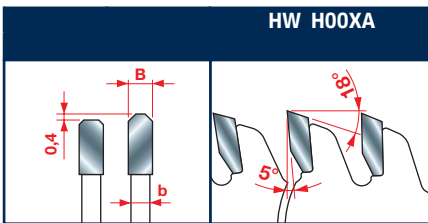

Tooth features - Caratteristiche del dente

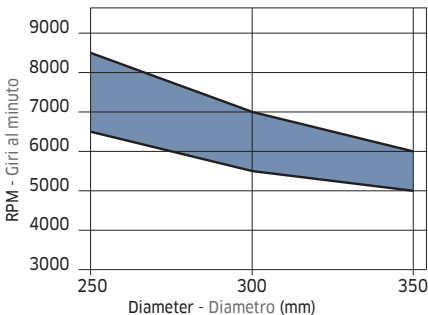

Minimum and maximum RPM based on the blade diameter.  
Fascia del N. giri minimo e massimo consigliati in funzione del diametro della lama.

	Ultimate Eccellente	High Ottimo	Good Buono
Solid surfaces Materiali polimerici			

# LU5A

## HW - Saw blades to cut non-ferrous metals HW - Lama per il taglio di metalli non ferrosi

To cut solid drawn products with a thickness between 2 and 10 mm.

**Machines:** Single or double miter saws with mechanical clamping of the piece.

**Features:** Flat-triple chip tooth with positive cutting angle.

**Material:** Aluminum and non-ferrous metals.

Per il taglio di trafilati pieni con spessore da 2 a 10 mm.

**Macchine:** Troncatrici singole o doppie con bloccaggio meccanico del pezzo.

**Caratteristiche:** Dentatura piano-trapezoidale con angolo di taglio positivo.

**Materiale:** Alluminio e metalli non ferrosi.

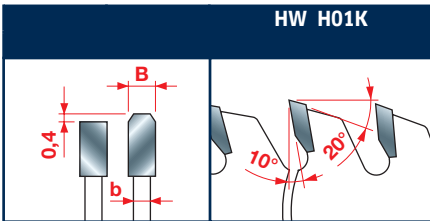

Tooth features - Caratteristiche del dente

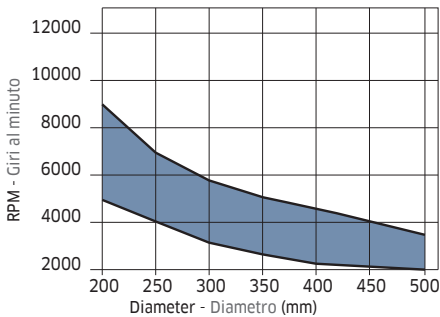

Minimum and maximum RPM based on the blade diameter.

Fascia del N. giri minimo e massimo consigliati in funzione del diametro della lama.

**FT02:** 2/9/46,4 + 2/10/60

	D mm	B mm	b mm	d mm	Z	NL FT	Code Codice	SAP SAP
	200	2,8	2,2	30	54		<b>LU5A 0100</b>	F03FS05181
	250	3,5	3,0	30	60	FT02	<b>LU5A 0200</b>	F03FS05182
	250	3,5	3,0	32	60	2/11/63	<b>LU5A 0300</b>	F03FS05183
	275	3,5	3,0	40	68	2/9/55+4/12/64	<b>LU5A 0400</b>	F03FS05185
	300	3,5	3,0	30	72	FT02	<b>LU5A 0500</b>	F03FS05186
	300	3,5	3,0	32	72	2/11/63	<b>LU5A 0600</b>	F03FS05187
	330	3,5	3,0	30	84	FT02	<b>LU5A 0800</b>	F03FS05190
	330	3,5	3,0	32	84	2/11/63	<b>LU5A 0900</b>	F03FS05192
	350	3,5	3,0	30	84	FT02	<b>LU5A 1000</b>	F03FS05193
	350	3,5	3,0	32	84	2/11/63	<b>LU5A 1100</b>	F03FS05194
	350	3,5	3,0	40	84	2/9/55+4/12/64	<b>LU5A 1200</b>	F03FS05196
	370	3,5	3,0	30	90		<b>LU5A 1300</b>	F03FS05197
	370	3,5	3,0	50	90	4/15/80	<b>LU5A 1400</b>	F03FS05198
	380	3,5	3,0	32	96	2/11/63	<b>LU5A 1500</b>	F03FS05199
	400	3,5	3,0	30	96	2/11/63	<b>LU5A 1600</b>	F03FS05200
	400	3,5	3,0	32	96	2/11/63	<b>LU5A 1700</b>	F03FS05202
	400	3,5	3,0	40	96	2/12/64+2/15/80	<b>LU5A 1800</b>	F03FS05205
	400	3,5	3,0	50	96	4/15/80	<b>LU5A 1900</b>	F03FS05206
	420	3,5	3,0	30	96	2/11/70	<b>LU5A 2000</b>	F03FS05207
	450	4,0	3,2	30	108	2/11/63	<b>LU5A 2100</b>	F03FS05208
	450	4,0	3,2	32	108	2/11/63	<b>LU5A 2200</b>	F03FS05210
	450	4,0	3,2	40	108	2/12/64+2/15/80	<b>LU5A 2300</b>	
	450	4,0	3,2	50	108	4/15/80	<b>LU5A 2400</b>	F03FS07420
	500	4,0	3,2	30	120	2/10,5/70	<b>LU5A 2500</b>	F03FS05212
	500	4,0	3,2	32	120	2/11/63	<b>LU5A 2600</b>	F03FS05214
	500	4,0	3,2	50	120	4/15/80	<b>LU5A 2700</b>	
	530	4,2	3,5	30	126	2/10,5/70	<b>LU5A 2800</b>	F03FS06607
	550	4,2	3,5	30	132	2/10,5/70	<b>LU5A 2900</b>	F03FS06608

Ultimate Eccellente	High Ottimo	Good Buono
------------------------	----------------	---------------

Non-ferrous metals  
Metalli non ferrosi

# LU5B

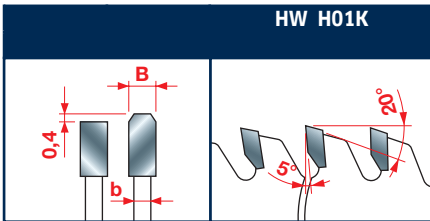
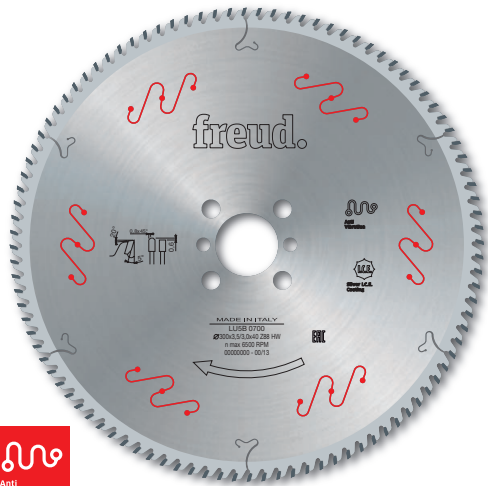

Tooth features - Caratteristiche del dente

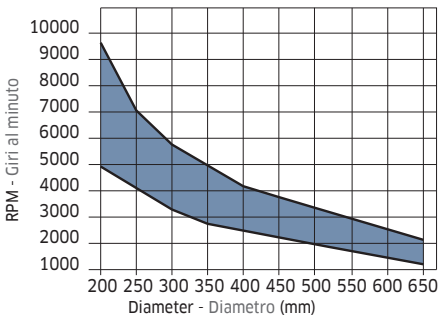

Minimum and maximum RPM based on the blade diameter.  
Fascia del N. giri minimo e massimo consigliati in funzione del diametro della lama.

## HW - Saw blades to cut non-ferrous metals HW - Lama per il taglio di metalli non ferrosi

To cut drawn products and tubes with a thickness between 2 and 5 mm, as well as polymeric panels up to 20 mm.  
**Machines:** Single or double miter saws with mechanical clamping of the piece.  
**Features:** Flat-triple chip tooth with positive cutting angle.  
**Material:** Aluminum and non-ferrous metals, polymeric materials.

Per il taglio di profilati e tubolari con spessore da 2 a 5 mm e di pannelli polimerici fino a 20 mm.  
**Macchine:** Troncatrici singole o doppie con bloccaggio meccanico del pezzo.  
**Caratteristiche:** Piano-trapezoidale con angolo di taglio positivo.  
**Materiale:** Alluminio e metalli non ferrosi, materiali polimerici.

**FT02:** 2/9/46,4 + 2/10/60

	D mm	B mm	b mm	d mm	Z	NL FT	Code Codice	SAP SAP
	200	2,8	2,2	30	64		<b>LU5B 0100</b>	F03FS05217
	250	3,5	3,0	30	80	FT02	<b>LU5B 0200</b>	F03FS05218
	250	3,5	3,0	32	80	2/11/63	<b>LU5B 0300</b>	F03FS05221
	275	3,5	3,0	40	84	2/9/55+4/12/64	<b>LU5B 0400</b>	F03FS05223
	300	3,5	3,0	30	88	FT02	<b>LU5B 0500</b>	F03FS05224
	300	3,5	3,0	32	88	2/11/63	<b>LU5B 0600</b>	F03FS05225
	300	3,5	3,0	40	88	2/9/55+4/12/64	<b>LU5B 0700</b>	F03FS05227
	300	3,5	3,0	30	96	FT02	<b>LU5B 0800</b>	F03FS05228
	300	3,5	3,0	32	96	2/11/63	<b>LU5B 0900</b>	F03FS05230
	300	3,5	3,0	40	96	2/9/55+4/12/64	<b>LU5B 1000</b>	F03FS05232
	330	3,5	3,0	30	104	FT02	<b>LU5B 1100</b>	F03FS05233
	330	3,5	3,0	32	104	2/11/63	<b>LU5B 1200</b>	F03FS05234
	350	3,5	3,0	30	96	FT02	<b>LU5B 1300</b>	F03FS05235
	350	3,5	3,0	32	96	2/11/63	<b>LU5B 1400</b>	F03FS05236
	350	3,5	3,0	40	96	2/9/55+4/12/64	<b>LU5B 1500</b>	F03FS05238
	350	3,5	3,0	30	108	FT02	<b>LU5B 1600</b>	F03FS05239
	350	3,5	3,0	32	108	2/11/63	<b>LU5B 1700</b>	F03FS05240
	350	3,5	3,0	40	108	2/9/55+4/12/64	<b>LU5B 1800</b>	F03FS05242
	370	3,5	3,0	30	112		<b>LU5B 1900</b>	
	370	3,5	3,0	50	112	4/15/80	<b>LU5B 2000</b>	F03FS05243
	380	3,5	3,0	32	112	2/11/63	<b>LU5B 2100</b>	F03FS05244
	400	3,5	3,0	30	120	2/11/63	<b>LU5B 2200</b>	F03FS05245
	400	3,5	3,0	32	120	2/11/63	<b>LU5B 2300</b>	F03FS05246
	400	3,5	3,0	40	120	2/12/64+2/15/80	<b>LU5B 2400</b>	F03FS05248
	400	3,5	3,0	50	120	4/15/80	<b>LU5B 2500</b>	F03FS05249
	420	3,5	3,0	30	120	2/11/70	<b>LU5B 2600</b>	F03FS05250
	450	4,0	3,2	30	128		<b>LU5B 2700</b>	F03FS05251
	450	4,0	3,2	32	128	2/11/63	<b>LU5B 2800</b>	F03FS05252
	500	4,0	3,2	30	140	2/10,5/70	<b>LU5B 3100</b>	F03FS05254
	500	4,0	3,2	32	140	2/11/63	<b>LU5B 3200</b>	F03FS05255
	550	4,2	3,5	30	148	2/11/63	<b>LU5B 3500</b>	F03FS05257
	550	4,2	3,5	32	148	2/11/63	<b>LU5B 3800</b>	F03FS05260
	600	4,8	3,8	30	156		<b>LU5B 3600</b>	F03FS05258

Ultimate Eccellente	High Ottimo	Good Buono

Non-ferrous metals  
Metalli non ferrosi

## HW - Saw blades to cut non-ferrous metals HW - Lama per il taglio di metalli non ferrosi

To cut solid drawn products whose thickness exceeds 3 mm. It is recommended to use it with the saw blade over the workpiece to be cut.

**Machines:** Miter saws with manual or mechanical clamping of the piece.

**Features:** Flat-triple chip tooth with negative cutting angle.

**Material:** Aluminum and non-ferrous metals.

Per il taglio di trafilati pieni con spessore oltre 3 mm. Si consiglia l'uso con la lama sopra il pezzo da tagliare.

**Macchine:** Troncatrici con bloccaggio manuale o meccanico del pezzo.

**Caratteristiche:** Piano-trapezoidale con angolo di taglio negativo.

**Materiale:** Alluminio e metalli non ferrosi.

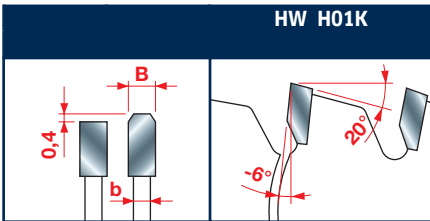

Tooth features - Caratteristiche del dente

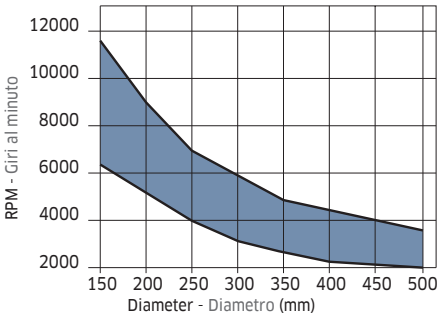

Minimum and maximum RPM based on the blade diameter.

Fascia del N. giri minimo e massimo consigliati in funzione del diametro della lama.

**FT01:** 2/7/42 + 2/9/46,4 + 2/10/60

**FT02:** 2/9/46,4 + 2/10/60

D	B	b	d	Z	NL	Code	SAP
mm	mm	mm	mm		FT	Code	SAP
180	2,8	2,2	20	42		LU5C 0100	F03FS07195
180	2,8	2,2	30	42		LU5C 0200	F03FS05261
200	2,8	2,2	30	48		LU5C 0300	F03FS05262
250	3,5	3,0	30	54		LU5C 0400	F03FS05263
275	3,5	3,0	40	60		LU5C 0600	F03FS05264
300	3,5	3,0	30	72	FT02	LU5C 0700	F03FS05265
300	3,5	3,0	32	72	2/11/63	LU5C 0800	F03FS05266
300	3,5	3,0	40	72	2/9/55+4/12/64	LU5C 0900	F03FS05267
330	3,5	3,0	30	80		LU5C 1000	F03FS05268
330	3,5	3,0	32	80	2/11/63	LU5C 1100	F03FS05269
350	3,5	3,0	30	84	FT01	LU5C 1200	F03FS05270
350	3,5	3,0	32	84	2/11/63	LU5C 1300	F03FS05271
350	3,5	3,0	40	84	2/9/55+4/12/64	LU5C 1400	F03FS05272
370	3,5	3,0	30	90		LU5C 1500	F03FS05273
370	3,5	3,0	50	90	4/15/80	LU5C 1600	F03FS05274
380	3,5	3,0	32	96	2/11/63	LU5C 1700	F03FS05275
400	3,5	3,0	30	96	2/11/70	LU5C 1800	F03FS05276
400	3,5	3,0	32	96	2/11/63	LU5C 1900	F03FS05277
400	3,5	3,0	40	96	2/15/80+2/12/64	LU5C 2000	F03FS05278
400	3,5	3,0	50	96	4/15/80	LU5C 2100	F03FS05279
420	4,0	3,2	30	96	2/11/70	LU5C 2200	F03FS05280
420	4,0	3,2	40	96		LU5C 2300	F03FS05281
450	4,0	3,2	30	108		LU5C 2400	F03FS05282
450	4,0	3,2	32	108	2/11/63	LU5C 2500	F03FS05283
450	4,0	3,2	40	108	2/15/80+2/12/64	LU5C 2600	F03FS05284
450	4,0	3,2	50	108	4/15/80	LU5C 2700	F03FS05285
500	4,0	3,2	30	120		LU5C 2800	F03FS06110
500	4,0	3,2	32	120	2/11/63	LU5C 2900	F03FS05286

Ultimate	High	Good
Eccellente	Ottimo	Buono

Non-ferrous metals  
Metalli non ferrosi

# LU5D

## HW - Saw blades to cut non-ferrous metals HW - Lama per il taglio di metalli non ferrosi

To cut drawn products and tubes whose thickness doesn't exceed 3 mm. It is recommendable to use it with the saw blade over the workpiece to be cut.

**Machines:** Miter saws with manual or mechanical clamping of the piece.

**Features:** Flat-triple chip tooth with negative cutting angle.

**Material:** Aluminum and non-ferrous metals.

Per il taglio di profilati e tubolari con spessore fino a 3 mm. Si consiglia l'uso con la lama sopra il pezzo da tagliare.

**Macchine:** Troncatrici con bloccaggio manuale o meccanico del pezzo.

**Caratteristiche:** Piano-trapezoidale con angolo di taglio negativo.

**Materiale:** Alluminio e metalli non ferrosi.

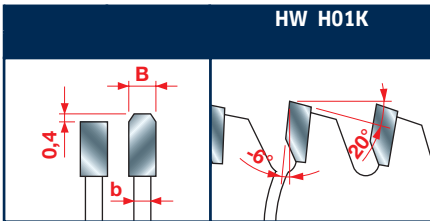

Tooth features - Caratteristiche del dente

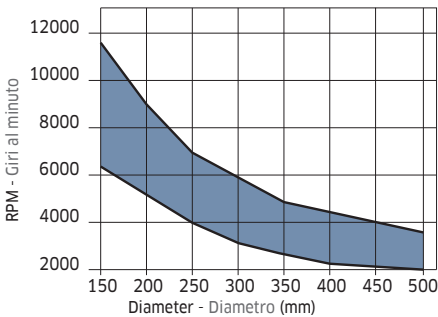

Minimum and maximum RPM based on the blade diameter.  
Fascia del N. giri minimo e massimo consigliati in funzione del diametro della lama.

**FT02:** 2/9/46,4 + 2/10/60

D	B	b	d	Z	NL	Code	SAP
mm	mm	mm	mm		FT	Codice	SAP
160	2,8	2,2	20	42		<b>LU5D 0100</b>	F03FS05288
190	2,8	2,2	30	54		<b>LU5D 0200</b>	F03FS05289
200	2,8	2,2	30	60		<b>LU5D 0300</b>	F03FS05290
210	2,8	2,2	30	60		<b>LU5D 0400</b>	F03FS05291
216	2,8	2,2	30	60		<b>LU5D 0500</b>	F03FS05292
220	3,0	2,5	30	64	FT02	<b>LU5D 0600</b>	F03FS05293
230	3,0	2,5	30	64		<b>LU5D 0700</b>	F03FS05294
250	3,5	3,0	30	80	FT02	<b>LU5D 0800</b>	F03FS05295
250	3,5	3,0	32	80	2/11/63	<b>LU5D 0900</b>	F03FS05297
250	3,5	3,0	40	80	2/9/55+4/12/64	<b>LU5D 1000</b>	F03FS05299
275	3,5	3,0	40	84	2/9/55+4/12/64	<b>LU5D 1100</b>	F03FS05300
300	3,5	3,0	30	96	FT02	<b>LU5D 1200</b>	F03FS05301
300	3,5	3,0	32	96	2/11/63	<b>LU5D 1300</b>	F03FS05303
300	3,5	3,0	40	96	2/9/55+4/12/64	<b>LU5D 1400</b>	F03FS05305
330	3,5	3,0	30	104	FT02	<b>LU5D 1500</b>	F03FS05306
330	3,5	3,0	32	104	2/11/63	<b>LU5D 1600</b>	F03FS05308
350	3,5	3,0	30	108	FT02	<b>LU5D 1700</b>	F03FS05309
350	3,5	3,0	32	108	2/11/63	<b>LU5D 1800</b>	F03FS05311
350	3,5	3,0	40	108	2/9/55+4/12/64	<b>LU5D 1900</b>	F03FS05313
370	3,5	3,0	30	108		<b>LU5D 2000</b>	F03FS05314
380	3,5	3,0	32	108	2/11/63	<b>LU5D 2200</b>	F03FS05315
400	3,5	3,0	30	120		<b>LU5D 2300</b>	F03FS05316
400	3,5	3,0	32	120	2/11/63	<b>LU5D 2400</b>	F03FS05317
400	3,5	3,0	40	120	2/15/80+2/12/64	<b>LU5D 2500</b>	F03FS05318
400	3,5	3,0	50	120	4/15/80	<b>LU5D 2600</b>	F03FS05319
420	4,0	3,2	30	120	2/11/70	<b>LU5D 2700</b>	F03FS05320
420	4,0	3,2	40	120		<b>LU5D 2800</b>	F03FS05321
450	4,0	3,2	30	128		<b>LU5D 2900</b>	F03FS05322
500	4,0	3,2	32	140	2/11/63	<b>LU5D 3400</b>	F03FS05323

Ultimate	High	Good
Eccellente	Ottimo	Buono
	●	

Non-ferrous metals  
Metalli non ferrosi

## HW - Saw blades to cut non-ferrous metals HW - Lama per il taglio di metalli non ferrosi

To cut special drawn products, such as tubes and similar products having ultrathin walls. The reduced thickness allows an excellent cutting finish, without splintering, and optimises its employment in low-power machines, too.

**Machines:** Miter saws with mechanical clamping of the piece.

**Features:** Flat-triple chip tooth with positive cutting angle.

**Material:** Aluminum, non-ferrous metals.

Per il taglio di profilati speciali come tubolari e similari con spessore di parete ultrasottile. Lo spessore ridotto consente di ottenere un ottimo grado di finitura di taglio, senza scheggiature ed ottimizza l'impiego anche su macchine a bassa potenza.

**Macchine:** Troncatrici con bloccaggio meccanico del pezzo.

**Caratteristiche:** Piano-trapezoidale con angolo di taglio positivo.

**Materiale:** Alluminio, metalli non ferrosi.

**FT01:** 2/7/42 + 2/9/46,4 + 2/10/60

**FT02:** 2/9/46,4 + 2/10/60

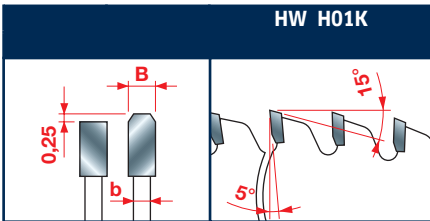

Tooth features - Caratteristiche del dente

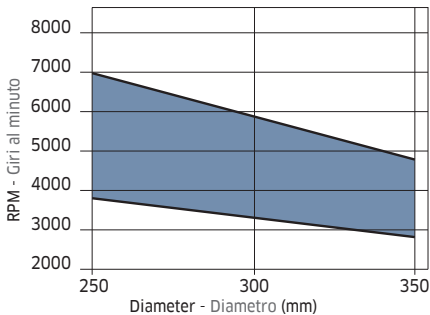

Minimum and maximum RPM based on the blade diameter.

Fascia del N. giri minimo e massimo consigliati in funzione del diametro della lama.

	D mm	B mm	b mm	d mm	Z	NL FT	Code Codice	SAP SAP
	250	2,8	2,2	30	100	FT01	LU5E 0100	F03FS05324
	250	2,8	2,2	32	100	2/11/63	LU5E 0200	F03FS05325
	255	2,8	2,2	25,4	100		LU5E 0300	F03FS05327
	255	2,8	2,2	25,4	120		LU5E 0400	F03FS05329
	300	3,0	2,5	30	100	FT02	LU5E 0500	F03FS05331
	300	3,0	2,5	30	120	FT02	LU5E 0700	F03FS05334
	300	3,0	2,5	32	120	2/11/63	LU5E 0800	F03FS05337
	305	3,0	2,5	25,4	120		LU5E 0600	F03FS05333
	350	3,0	2,5	30	100	FT02	LU5E 0900	F03FS05339
	350	3,0	2,5	32	100	2/11/63	LU5E 1000	F03FS05340
	350	3,0	2,5	30	120	FT02	LU5E 1100	F03FS05341
	350	3,0	2,5	32	120	2/11/63	LU5E 1200	F03FS05342

Non-ferrous metals  
Metalli non ferrosi

Ultimate Eccellente	High Ottimo	Good Buono
	●	

# LU6A

## HW - Saw blades to cut ferrous metals HW - Lame per il taglio di metalli ferrosi

To cut drawn products, tubes and iron rods.

**Machines:** Miter saws in low-power dry cut (without lubricants).

**Features:** Double-triple chip tooth.

**Material:** For ferrous metals, mild steel, copper etc.

**WARNING: The above-mentioned sawblades are not suitable to cut the following materials:**

- Non-ferrous metals (aluminum).
- Wood, glass, conglomerate, etc.

Make sure that the workpieces to be cut are well fastened.

Per il taglio di profilati, tubolari e tondini pieni.

**Macchine:** Troncatrici a bassa velocità di rotazione con taglio a secco (senza lubrificanti).

**Caratteristiche:** Dentatura doppio-trapezio.

**Materiale:** Per metalli ferrosi, acciaio dolce, rame, ecc.

**ATTENZIONE: Le lame sopra non sono indicate per tagliare i seguenti materiali:**

- Metalli non ferrosi (alluminio).
- Legno, vetro, conglomerati, ecc.

**FT01:** 2/7/42 + 2/9/46,4 + 2/10/60

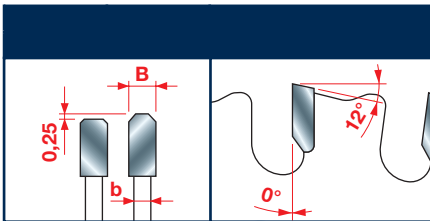

Tooth features - Caratteristiche del dente

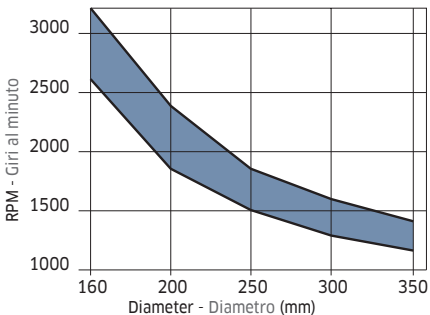

Minimum and maximum RPM based on the blade diameter.  
Fascia del N. giri minimo e massimo consigliati in funzione del diametro della lama.

D mm	B mm	b mm	d mm	Z	NL FT	Code Codice	SAP SAP
160	2,0	1,6	20	30		LU6A 0100	F03FS05342
184	2,0	1,6	15,88	38		LU6A 0200	F03FS05343
184	2,0	1,6	15,88	48		LU6A 1900	F03FS05344
190	2,0	1,6	30	38		LU6A 0300	F03FS05345
210	2,0	1,6	30	40		LU6A 0400	F03FS05346
216	2,0	1,6	30	40		LU6A 0500	F03FS05347
230	2,2	1,8	30	48	FT01	LU6A 0600	F03FS05348
230	2,4	2,0	25,4	44		LU6A 0700	F03FS05349
250	2,4	2,0	30	48	FT01	LU6A 0800	F03FS05350
254	2,4	2,0	25,4	50		LU6A 0900	F03FS05351
254	2,4	2,0	25,4	60		LU6A 1000	F03FS05352
300	2,6	2,2	30	60	FT01	LU6A 1700	F03FS05353
300	2,6	2,2	30	80	FT01	LU6A 1800	F03FS05354
305	2,6	2,2	25,4	60		LU6A 1100	F03FS05355
305	2,6	2,2	25,4	80		LU6A 1200	F03FS05356
350	2,6	2,2	30	72	FT01	LU6A 1300	F03FS05357
350	2,6	2,2	30	90	FT01	LU6A 1400	F03FS05358
355	2,6	2,2	25,4	72		LU6A 1500	F03FS05359
355	2,6	2,2	25,4	90		LU6A 1600	F03FS05360

Saw blade diameter Diametro lama	Maximum RPM Max N. giri
160 mm	3.200
184 mm	3.000
190 mm	2.600
210 mm	2.300
216 mm	2.200
230 mm	2.100
250 mm	1.900
255 mm	1.900
300 mm	1.800
305 mm	1.800
315 mm	1.700
350 mm	1.600
355 mm	1.600
400 mm	1.400

Table of maximum RPM based on the blade diameter, for saw blades to cut ferrous metals.  
Tabella del N. giri massimo in funzione del diametro della lama, riferita a lame per il taglio di metalli ferrosi.

	Ultimate Eccellente	High Ottimo	Good Buono
Non-ferrous metals Metalli non ferrosi			●

# LP20M

## HW - Saw blades to cut solid wood HW - Lame per il taglio di legno massiccio

These blades are designed with a low number of teeth and are particularly fit for long grain cutting solid wood. These blades give a good finish if used in this way.

**Machines:** Portable machines.

**Features:** ATB 15° tooth with positive cutting angle.

**Material:** Solid soft and hard wood.

Queste lame sono state costruite con un basso numero di denti e sono particolarmente indicate per la lavorazione, con buona finitura, di legno naturale lungo vena.

**Macchine:** Macchine portatili.

**Caratteristiche:** Dentatura alterna a 15° con angolo di taglio positivo.

**Materiale:** Legni massicci teneri e duri.

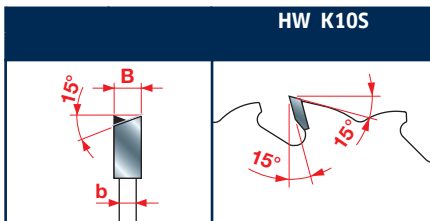
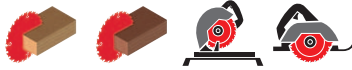

Tooth features - Caratteristiche del dente

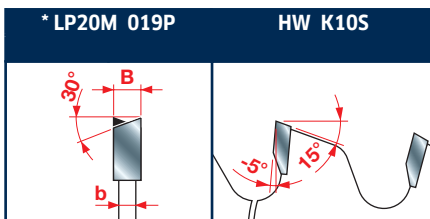

Tooth features - Caratteristiche del dente

D mm	B mm	b mm	d mm	Z	NL FT	Code Codice	SAP SAP
150	2,4	1,6	16	12		<b>LP20M 004P</b>	F03FS03612
150	2,4	1,6	20	12	2/6/32	<b>LP20M 005P</b>	F03FS03613
160	2,4	1,6	16	12		<b>LP20M 006P</b>	F03FS03614
160	2,4	1,6	20	12	2/6/32	<b>LP20M 007P</b>	F03FS03615
160	2,4	1,6	30	12	2/6/42	<b>LP20M 008P</b>	F03FS03616
180	2,4	1,6	20	12	2/6/32	<b>LP20M 010P</b>	F03FS03618
180	2,4	1,6	30	12	2/6/42	<b>LP20M 011P</b>	F03FS03619
184	2,4	1,6	16	12		<b>LP20M 012P</b>	F03FS03620
190	2,4	1,6	16	12		<b>LP20M 013P</b>	F03FS03621
190	2,4	1,6	20	12	2/6/32	<b>LP20M 014P</b>	F03FS03622
190	2,4	1,6	30	12	2/6/42	<b>LP20M 015P</b>	F03FS03623
200	2,4	1,6	30	16	2/6/42	<b>LP20M 016P</b>	F03FS03624
210	2,4	1,6	25	16		<b>LP20M 017P</b>	F03FS03625
210	2,4	1,6	30	16	2/6/42	<b>LP20M 018P</b>	F03FS03626
216	2,4	1,8	30	24*	2/6/42	<b>LP20M 019P</b>	F03FS03627
220	2,4	1,6	30	16	2/6/42	<b>LP20M 020P</b>	F03FS03628
230	2,8	1,8	30	20	2/6/42	<b>LP20M 021P</b>	F03FS03629
235	2,8	1,8	30	24	2/6/42	<b>LP20M 023P</b>	F03FS03631
240	2,8	1,8	30	24	2/6/42	<b>LP20M 024P</b>	F03FS03632
250	2,8	1,8	30	24	2/6/42	<b>LP20M 025P</b>	F03FS03633

# LP30M

## HW - Saw blades to cut solid wood HW - Lame per il taglio di legno massiccio

These blades are designed with an average number of teeth and are particularly fit for both long grain and cross grain cutting solid wood. These blades give a good finish if used in this way.

**Machines:** Portable machines.

**Features:** ATB 15° tooth with positive cutting angle.

**Material:** Solid soft and hard wood.

Lame costruite con un numero medio di denti, per la lavorazione con buona finitura di legno naturale lungo e trasverso vena.

**Macchine:** Macchine portatili.

**Caratteristiche:** Dentatura alterna a 15° con angolo di taglio positivo.

**Materiale:** Legni massicci teneri e duri.

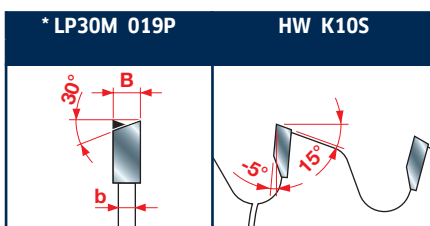
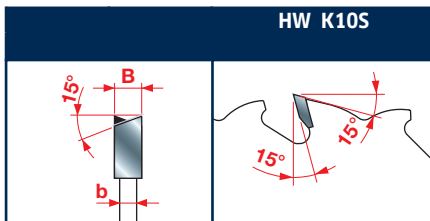

Tooth features - Caratteristiche del dente

D	B	b	d	Z	NL	Code	SAP
mm	mm	mm	mm		FT	Codice	SAP
125	2,4	1,6	20	24	2/6/32	LP30M 001P	F03FS03636
130	2,4	1,6	20	24	2/6/32	LP30M 002P	F03FS03637
140	2,4	1,6	20	24	2/6/32	LP30M 003P	F03FS03638
150	2,4	1,6	16	24		LP30M 004P	F03FS03639
150	2,4	1,6	20	24	2/6/32	LP30M 005P	F03FS03640
160	2,4	1,6	16	24		LP30M 006P	F03FS03642
160	2,4	1,6	20	24	2/6/32	LP30M 007P	F03FS03643
160	2,4	1,6	30	24	2/6/42	LP30M 008P	F03FS03644
170	2,4	1,6	30	24	2/6/42	LP30M 009P	F03FS03646
180	2,4	1,6	20	24	2/6/42	LP30M 010P	F03FS03647
180	2,4	1,6	30	24	2/6/42	LP30M 011P	F03FS03649
184	2,4	1,6	16	24	2/6/42	LP30M 012P	F03FS03652
190	2,4	1,6	16	24	2/6/42	LP30M 013P	F03FS03655
190	2,4	1,6	20	24	2/6/42	LP30M 014P	F03FS03657
190	2,4	1,6	30	24	2/6/42	LP30M 015P	F03FS03658
200	2,4	1,6	30	30	2/6/42	LP30M 016P	F03FS03660
210	2,4	1,6	25	30	2/6/42	LP30M 017P	F03FS03662
210	2,4	1,6	30	30	2/6/42	LP30M 018P	F03FS03663
216	2,4	1,8	30	48 *	2/6/42	LP30M 019P	F03FS03665
220	2,4	1,6	30	30	2/6/42	LP30M 020P	F03FS03667
230	2,8	1,8	30	34	2/6/42	LP30M 021P	F03FS03669
235	2,8	1,8	25	34	2/6/42	LP30M 022P	F03FS03671
235	2,8	1,8	30	34	2/6/42	LP30M 023P	F03FS03673
240	2,8	1,8	30	36	2/6/42	LP30M 024P	F03FS03675
250	2,8	1,8	30	40	2/6/42	LP30M 025P	F03FS03677

# LP40M



## HW K10S

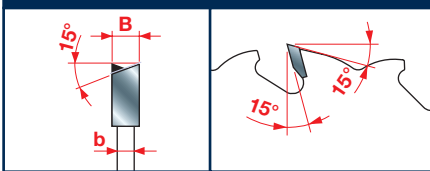

## HW - Saw blades to cut solid wood HW - Lame per il taglio di legno massiccio

These blades are designed with a high number of teeth and are particularly fit for cross grain cutting solid wood. These blades give a good finish if used in this way.  
**Machines:** Portable machines.

**Features:** ATB 15° tooth with positive cutting angle.

**Material:** Solid soft and hard wood.

Queste lame con un alto numero di denti sono particolarmente indicate per la lavorazione, con finitura eccellente, di legno naturale traverso vena.

**Macchine:** Macchine portatili.

**Caratteristiche:** Dentatura alterna a 15° con angolo di taglio positivo.

**Materiale:** Legni massicci teneri e duri.

D	B	b	d	Z	NL	Code	SAP
mm	mm	mm	mm		FT	Codice	SAP
160	2,4	1,6	16	40	2/6/42	LP40M 006P	F03FS03701
160	2,4	1,6	20	40	2/6/42	LP40M 007P	F03FS03702
160	2,4	1,6	30	40	2/6/42	LP40M 008P	F03FS03703
170	2,4	1,6	30	40	2/6/42	LP40M 009P	F03FS03704
180	2,4	1,6	20	40	2/6/42	LP40M 010P	F03FS03705
180	2,4	1,6	30	40	2/6/42	LP40M 011P	F03FS03706
184	2,4	1,6	16	40	2/6/42	LP40M 012P	F03FS03708
190	2,4	1,6	16	40	2/6/42	LP40M 013P	F03FS03711
190	2,4	1,6	20	40	2/6/42	LP40M 014P	F03FS03712
190	2,4	1,6	30	40	2/6/42	LP40M 015P	F03FS03713
200	2,4	1,6	30	40	2/6/42	LP40M 016P	F03FS03714
210	2,4	1,6	25	40	2/6/42	LP40M 017P	F03FS03715
210	2,4	1,6	30	40	2/6/42	LP40M 018P	F03FS03716
220	2,4	1,6	30	40	2/6/42	LP40M 020P	F03FS03720
230	2,8	1,8	30	48	2/6/42	LP40M 021P	F03FS03721
235	2,8	1,8	25	48	2/6/42	LP40M 022P	F03FS03722
235	2,8	1,8	30	48	2/6/42	LP40M 023P	F03FS03724
240	2,8	1,8	30	48	2/6/42	LP40M 024P	F03FS03725
250	2,8	1,8	30	60	2/6/42	LP40M 025P*	F03FS03727

\* Item LP40M 025P is not designed with anti-kickback.

\* L'articolo LP40M 025P non ha il limitatore di truciolo.

# LP40M

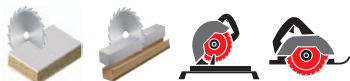

## HW K10S

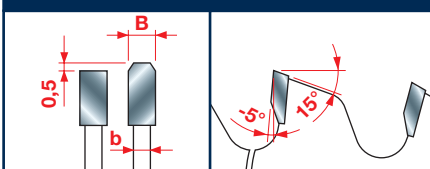

## HW - Saw blades to cut non-ferrous metals HW - Lame per il taglio di metalli non ferrosi

To size bilaminated panels and to cut solid drawn products and tubes.

**Machines:** Portable machines.

**Features:** Flat-triple chip tooth with negative cutting angle.

**Material:** Bilaminated panels, aluminum and non-ferrous metals.

Per la sezionatura di pannelli bilaminati ed il taglio di profilati, tubolari e trafileati.

**Macchine:** Macchine portatili.

**Caratteristiche:** Dentatura piano-trapezoidale con angolo di taglio negativo.

**Materiale:** Per pannelli bilaminati, alluminio e metalli non ferrosi.

D	B	b	d	Z	NL	Code	SAP
mm	mm	mm	mm		FT	Codice	SAP
160	2,2	1,6	20	48		LP40M 026P	F03FS03729
216	2,4	1,8	30	64		LP40M 019P	F03FS03718

Tooth features - Caratteristiche del dente

# LP60M

## HW - Saw blades for hardwood and softwood HW - Lame circolari per legno tenero e duro

### For ripping Per taglio lungo vena

D	B	b	d	Z	NL	Code	SAP
mm	mm	mm	mm		FT	Codice	SAP
300	3,2	2,2	30	48	2/6/42	LP60M 014P	F03FS03744

### For ripping and cross cutting Per taglio lungo e trasverso vena

D	B	b	d	Z	NL	Code	SAP
mm	mm	mm	mm		FT	Codice	SAP
260	2,6	1,8	30	60	2/6/42	LP60M 013P	F03FS03743
300	2,8	1,8	30	48	2/6/42	LP60M 003P	F03FS03733
300	3,2	2,2	30	60	2/6/42	LP60M 015P	F03FS03745
350	3,0	2,2	30	54	2/6/42	LP60M 007P	F03FS03737
350	3,5	2,5	30	72	2/6/42	LP60M 020P	F03FS03750

### For cross cutting Per taglio trasverso vena

D	B	b	d	Z	NL	Code	SAP
mm	mm	mm	mm		FT	Codice	SAP
250	3,2	2,2	30	60	2/6/42	LP60M 011P	F03FS03741
250	2,8	1,8	30	80	2/6/42	LP60M 001P	F03FS03731
280	2,8	1,8	30	64	2/6/42	LP60M 002P	F03FS03732
300	2,8	1,8	30	72	2/6/42	LP60M 004P	F03FS03734
300	2,8	1,8	30	96	2/6/42	LP60M 005P	F03FS03735
305	2,8	1,8	30	96	2/6/42	LP60M 006P	F03FS03736
350	3,0	2,2	30	108	2/6/42	LP60M 008P	F03FS03738

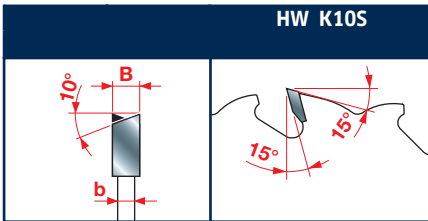
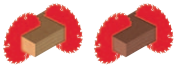

Tooth features - Caratteristiche del dente

# LP70M

## HW - Saw blades for on-site jobs HW - Lame per l'edilizia

Saw blades suitable for ripping and crosscutting.

**Machines:** Table saws.

**Features:** ATB tooth with positive cutting angle.

**Material:** Soft and hard solid wood and panels, even in case of nails or metal clips.

Lame per taglio lungo e trasverso vena.

**Macchine:** Seghe da banco.

**Caratteristiche:** Dente alterno con angolo di taglio positivo.

**Materiale:** Legni teneri e duri massicci e pannelli, anche con presenza di chiodi o graffe metalliche.



D mm	B mm	b mm	d mm	Z	NL FT	Code Codice	SAP SAP
300	2,6	1,8	25	24		<b>LP70M 004P</b>	F03FS03766
300	2,8	1,8	30	24	2/10/60	<b>LP70M 001P</b>	F03FS03762
315	3,2	2,2	30	24	2/10/50	<b>LP70M 003P</b>	F03FS03765
315	3,2	2,2	25	48		<b>LP70M 006P</b>	F03FS03768
350	3,0	2,2	30	28	2/10/60	<b>LP70M 002P</b>	F03FS03763
400	3,8	2,8	30	28	2/10/60	<b>LP70M 008P</b>	F03FS03770

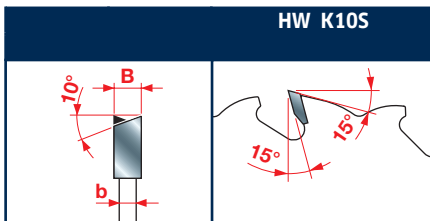

Tooth features - Caratteristiche del dente

# LP80M

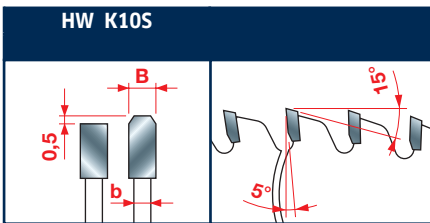

Tooth features - Caratteristiche del dente

# LP90M

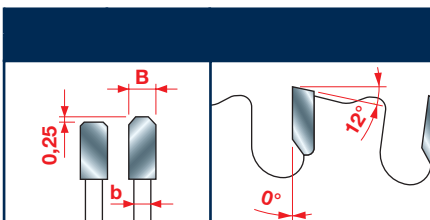

Tooth features - Caratteristiche del dente

## HW - Saw blades to cut non-ferrous metals HW - Lame per il taglio di metalli non ferrosi

To cut drawn products and tubes with a thickness between 2 and 5 mm, as well as polymeric panels up to 20 mm.

**Machines:** Portable machines.

**Features:** Flat-triple chip tooth with positive cutting angle.

**Material:** Aluminum and non-ferrous metals, polymeric materials.

Per il taglio di profilati e tubolari con spessore da 2 a 5 mm e di pannelli polimerici fino a 20 mm.

**Macchine:** Macchine portatili.

**Caratteristiche:** Piano-trapezoidale con angolo di taglio positivo.

**Materiale:** Alluminio e metalli non ferrosi, materiali polimerici.

**FT02:** 2/9/46,4 + 2/10/60

D mm	B mm	b mm	d mm	Z	NL FT	Code Codice	SAP SAP
250	2,8	2,2	30	80	2/10/60	LP80M 001P	F03FS03775
280	2,8	2,2	30	64	2/10/60	LP80M 002P	F03FS03776
300	2,8	2,2	30	96	2/10/60	LP80M 003P	F03FS03777
350	3,0	2,2	30	108	2/10/60	LP80M 004P	F03FS03778

## HW - Saw blades to cut ferrous metals HW - Lame per il taglio di metalli ferrosi

To cut drawn products and tubes with a thickness up to 4 mm, dry cut (without lubricants).

**Machines:** Portable machines.

**Features:** Flat-triple chip tooth.

**Material:** For ferrous metals and soft steel.

Per il taglio di profilati e tubolari con spessore fino a 4 mm con taglio a secco (senza lubrificanti).

**Macchine:** Macchine portatili.

**Caratteristiche:** Dentatura piano-trapezoidale.

**Materiale:** Per metalli ferrosi e acciaio dolce.

D mm	B mm	b mm	d mm	Z	NL FT	Code Codice	SAP SAP
160	2,0	1,6	20	30	2/6/42	LP90M 002P	F03FS07034
210	2,0	1,6	30	40	2/6/42	LP90M 005P	F03FS06239
230	2,2	1,8	30	44	2/6/42	LP90M 006P	F03FS06240

# LP85M

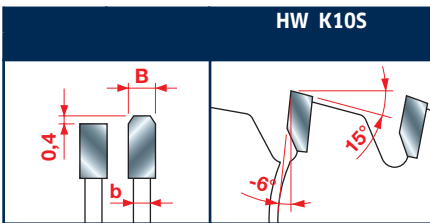
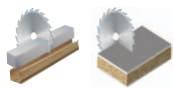

Tooth features - Caratteristiche del dente

# LP91M

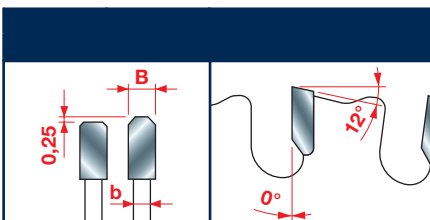
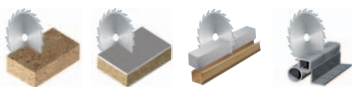

Tooth features - Caratteristiche del dente

## HW - Saw blades to cut aluminum and bilaminated panels HW - Lame per il taglio di alluminio e pannelli bilaminati

To size bilaminated panels and to cut solid drawn products and tubes.

**Machines:** Portable machines.

**Features:** Flat-triple chip tooth with negative cutting angle.

**Material:** Bilaminated panels, aluminum and non-ferrous metals.

Per la sezionatura di pannelli bilaminati ed il taglio di profilati, tubolari e trafilati.

**Macchine:** Macchine portatili.

**Caratteristiche:** Dentatura piano-trapezoidale con angolo di taglio negativo.

**Materiale:** Per pannelli bilaminati, alluminio e metalli non ferrosi.

	D mm	B mm	b mm	d mm	Z	NL FT	Code Codice	SAP SAP
	150	2,8	2,0	20	42	2/6/42	LP85M 001P	F03FS06229
	160	2,8	2,0	20	42	2/6/42	LP85M 002P	F03FS06230
	180	2,8	2,0	30	48	2/6/42	LP85M 003P	F03FS06231
	190	2,8	2,0	30	54	2/6/42	LP85M 004P	F03FS06232
	200	2,8	2,0	30	54	2/6/42	LP85M 005P	F03FS06233
	210	2,8	2,0	30	54	2/6/42	LP85M 006P	F03FS06234
	230	2,8	2,0	30	64	2/6/42	LP85M 007P	F03FS06235
	280	2,8	2,0	30	84	2/6/42	LP85M 008P	F03FS06223

## HW - Saw blades to cut multi-material HW - Lame per il taglio di materiali diversi

To cut iron profiles, tubing and angles with a thickness up to 3,2 mm.

**Machines:** Portable machines and miter saws.

**Features:** Flat-triple chip tooth.

**Material:** For bilaminated, chipboard, MDF, plywood, ferrous and non-ferrous metals, aluminium, plexiglas and plastic materials.

Per il taglio di tubi, angolari e profili in ferro con spessore fino a 3,2 mm.

**Macchine:** Macchine portatili e troncatrici.

**Caratteristiche:** Dentatura piano-trapezoidale.

**Materiale:** Per bilaminato, truciolare, MDF, multistrato, metalli ferrosi e non ferrosi, alluminio, plexiglas e materiali plastici.

	D mm	B mm	b mm	d mm	Z	NL FT	Code Codice	SAP SAP
	160	2,0	1,6	20	30	2/6/42	LP91M 001P	F03FS06251
	190	2,0	1,6	30	38	2/6/42	LP91M 002P	F03FS06252
	216	2,0	1,6	30	40	2/6/42	LP91M 003P	F03FS06253
	230	2,4	2,0	30	44	2/6/42	LP91M 004P	F03FS06254
	250	2,4	2,0	30	48	2/6/42	LP91M 005P	F03FS06255
	305	2,6	2,2	30	80	2/6/42	LP91M 006P	F03FS06256

## BL15M - BL20M

### Standard reduction rings for saw blades Bussole di riduzione rettificate per lame circolari

D mm	B mm	d mm	Code Codice	SAP SAP
20	1,5	16	<b>BL15M20160</b>	F03FS05360
30	1,5	16	<b>BL15M30160</b>	F03FS05361
30	1,5	20	<b>BL15M30200</b>	F03FS05362
30	1,5	25	<b>BL15M30250</b>	F03FS05363

D mm	B mm	d mm	Code Codice	SAP SAP
30	2,0	16	<b>BL20M30160</b>	F03FS05363
30	2,0	20	<b>BL20M30200</b>	F03FS05364
30	2,0	25	<b>BL20M30250</b>	F03FS05365
32	2,0	30	<b>BL20M32300</b>	F03FS05366

## OPT06

### Optional workings - Standard keyways Lavorazioni opzionali - Chiavette standard

D mm	B mm	Code Codice	SAP SAP
10	5	<b>OPT06 AA9</b>	F03FS05366
12	5	<b>OPT06 BA9</b>	F03FS05367
12,5	4	<b>OPT06 CA9</b>	F03FS05368
13	5	<b>OPT06 DA9</b>	F03FS05369
15	5	<b>OPT06 EA9</b>	F03FS05370
17	5	<b>OPT06 FA9</b>	F03FS05371
18	5	<b>OPT06 GA9</b>	F03FS05372
21	5	<b>OPT06 HA9</b>	F03FS05373

## OPT07

### Optional workings - Special keyways Lavorazioni opzionali - Chiavette speciali

Code Codice	SAP SAP
<b>OPT07 AA9</b>	F03FC16221

## OPT08

### Optional workings - Special reboring Lavorazioni opzionali - Allargatura fori

Code Codice	SAP SAP
<b>OPT08 AA9</b>	F03FS05372

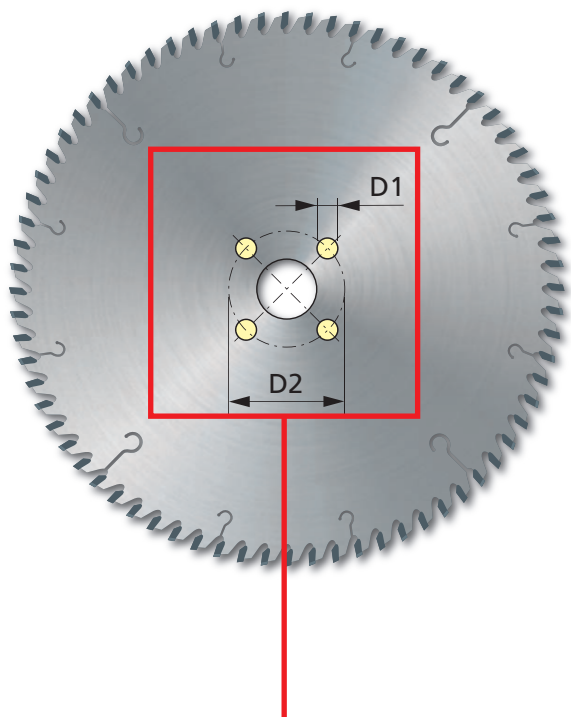

Specify no. of pin holes, diameter (D1) and PCD (D2).  
Indicare il n. di fori, il loro diametro (D1) e l'interasse (D2).

Number of holes Numero di fori	Code Codice	SAP SAP
1	<b>OPTFO AA9</b>	F03FS05372
2	<b>OPTFO AB9</b>	F03FS05373
3	<b>OPTFO AC9</b>	F03FS05374
4	<b>OPTFO AD9</b>	F03FS05375
5	<b>OPTFO AE9</b>	F03FS05376
6	<b>OPTFO AF9</b>	F03FS05377
7	<b>OPTFO AG9</b>	F03FS05378
8	<b>OPTFO AM9</b>	F03FS05379
10	<b>OPTFO AH9</b>	F03FS05380



# **Tips for the correct use of a saw blade**

## **Consigli per l'uso corretto di una lama**

# Tips for the correct use of a saw blade

## Consigli per l'uso corretto di una lama

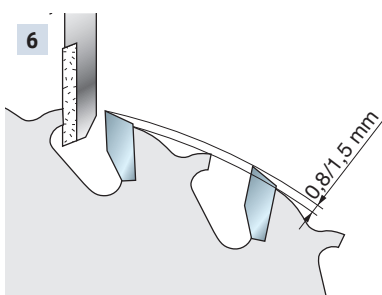
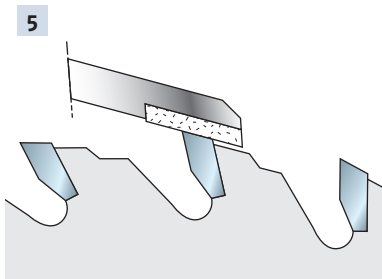
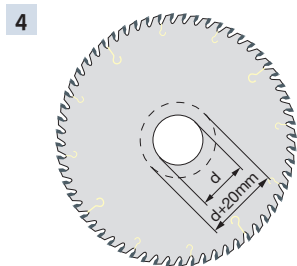
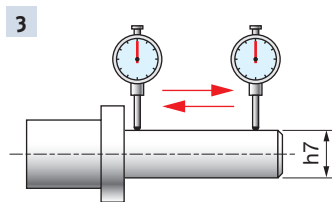
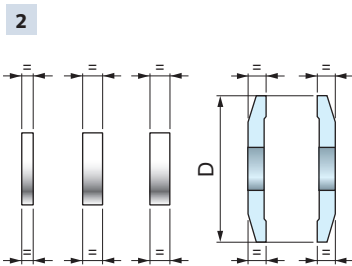
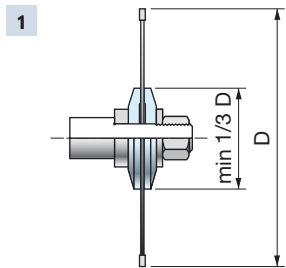

To obtain the best performance from a saw blade we suggest to follow these simple instructions:

- The machine must be in good condition, free of vibrations.
- The flanges used to secure the blade must be of the same diameter, at least 1/3 of the blade's diameter (Fig. 1).
- The flanges must be parallel to each other. Also check tolerances on diameters, sides and concentricity, by using a clock gauge (Fig. 2).
- The spacers must be perfectly parallel (Fig. 2).
- The spindle must be perfectly straight and with an H7 tolerance (Fig. 3).
- After continuous use, remove the blade and clean it with the appropriate solvents making sure to get rid of built up resin. For the synthetic coated (permaSHIELD) blades, it's sufficient to use warm water. In any case, avoid using solvents containing caustic soda.
- The blades must be sharpened as soon as they become dull, maintaining the original tooth angles.
- For sharpening, always use the correct grinding wheels and plenty of cooling liquid.
- Maximum re-boring of the blade is 20 mm of the original bore size. Above this value, the blade will lose its original tuning and overall performance will be affected (Fig. 4).
- Always keep spacers and flanges clean.
- When sharpening, the shoulder of the teeth must not be lowered more than needed. This operation must be done with appropriate precision machinery and never by hand. There is the risk of breaking the tip or upsetting the blade balance (Fig. 5 - 6).
- On ripping machines, the feeding track must be levelled with the fixed table.
- Before starting the cut of the material, make sure the blade is correctly locked according to the machine's specifications.

Per ottenere le massime prestazioni da una lama circolare è necessario rispettare scrupolosamente alcune semplici norme:

- La macchina su cui andranno montate le lame circolari deve essere efficiente e priva di vibrazioni.
- Le flange di serraggio devono essere di uguale diametro, che deve essere il massimo possibile e comunque mai meno di 1/3 del diametro della lama montata (Fig.1).
- Il foro delle flange di serraggio deve essere ortogonale alle superfici di appoggio e queste ultime devono essere perfettamente parallele tra loro (Fig. 2).
- Gli anelli distanziali devono essere perfettamente paralleli (Fig. 2).
- L'albero deve essere dritto ed in tolleranza h7 (Fig. 3).
- Prima di montare le lame sulla macchina è necessario pulirle bene, ed in caso di resine incollate sul corpo, anche con diluente. Per quanto riguarda le lame rivestite con materiale antiaderente (permaSHIELD) è sufficiente eseguire questa operazione con acqua calda. Evitare sempre l'uso di solventi a base caustica.
- Le lame devono essere affilate appena perdono il filo tagliente, rispettando gli angoli originali dei denti.
- Per l'affilatura usare mole appropriate mantenendo un'abbondante refrigerazione.
- L'allargatura massima consentita dal foro originale è di 20 mm. Oltre tale misura si compromette la tensionatura della lama e quindi il perfetto funzionamento della stessa (Fig. 4).
- Tenere puliti gli anelli distanziali e le flange di serraggio.
- Il corpo dietro il dente non deve essere abbassato più del necessario e non va mai fatto a mano in quanto si rischia la rottura della placchetta e la perdita dell'equilibratura propria della lama (Figg. 5 - 6).
- Sulle multilame, le rulliere di appoggio del materiale devono essere in piano con il banco macchina, sia in entrata che in uscita.
- Prima di iniziare il taglio del materiale accertarsi che la lama sia ben bloccata in modo tale da non girare sull'albero della macchina.

# Tips for the correct use of a saw blade

## Consigli per l'uso corretto di una lama

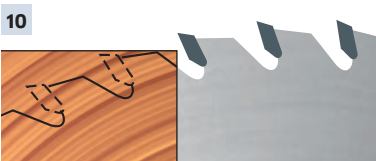
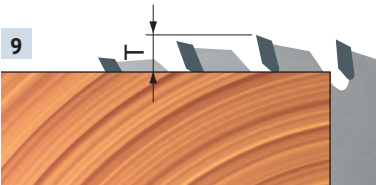
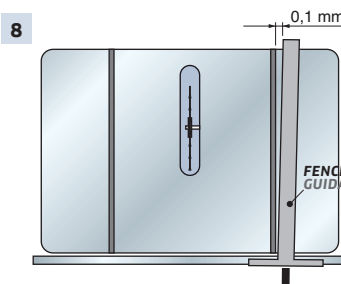
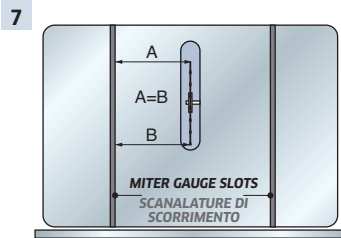

Table 1 - Tabella 1

Saw blade diameter Diametro lama	Maximum RPM Max N. giri
100 mm	23.000
125 mm	18.000
150 mm	14.500
180 mm	11.500
185 mm	11.000
200 mm	10.000
225 mm	8.500
250 mm	8.000
255 mm	7.800
280 mm	7.100
300 mm	6.500
320 mm	6.000
350 mm	5.500
380 mm	5.000
400 mm	4.700
430 mm	4.400
450 mm	4.200
500 mm	3.750
550 mm	3.400
600 mm	3.100
630 mm	2.950
650 mm	2.800
700 mm	2.600
730 mm	2.500
760 mm	2.400
800 mm	2.250

Not valid for saw blades to cut ferrous metals.  
Non valida per lame per il taglio di metalli ferrosi.

### SAW BLADE ALIGNMENT ON A TABLE SAW

- If the saw blade and the saw are not correctly aligned to the table and the fence, then there is the possibility that a serious accident may occur (for example, violent kickbacks) or that the workpiece may scorch or splinter. The first thing you must do is read the instruction sheet carefully. This is necessary so as you may acquire the understanding and comprehension of the corrections suggested in this section.
- Before carrying out the following instructions, make sure that the starter switch is off and that the machine is not connected to the socket.

#### Mounting the saw blade onto the table:

We advise you to use precise measuring instruments when mounting your saw blade. Clean the saw blade well, before mounting it onto the machine. Mount the saw blade onto the arbor. Adjust the arbor to its maximum height. With the aid of the most precise measuring instrument available, verify that the saw blade is parallel to the miter gauge slots (Fig. 7). Adjust as needed. This step is necessary to obtain crosscuts with the maximum in quality finish and for setting up the fence for ripping.

#### Positioning the fence for ripping:

After having positioned the saw blade so as it is parallel to the miter gauge slots, you may proceed with setting the fence. The fence should ideally be parallel to the saw blade. However since it is impossible to position the guide "exactly" it is necessary to leave a slight margin of clearance on the exit side of the cut so as to avoid the wood becoming wedged in between the fence and the saw blade.

Adjust the fence so as when it is aligned to the miter gauge slots, there is a space of 0,1 mm (fig. 8; for the correct adjustment, consult the machine's instruction manual).

- The maximum RPM of a circular saw blade varies according the diameter of the blade itself (table 1). If you exceed this limit, the saw blade will lose its characteristics, therefore influencing the cutting quality and the work life of the blade itself, not to mention the dangers implied to the user who may incur serious injury.
- The saw blade's projection (T) with respect to the workpiece must be at least equal to the height of the blade's tooth (fig. 9). Increase or decrease the projection of the saw blade to improve the quality of the cutting finish.
- The number of teeth cutting (teeth cutting the wood simultaneously - fig. 10) must be between 3 or 4. With less than three teeth cutting, the saw blade begins to vibrate leading to an uneven cut. If you want to cut workpieces with increased thicknesses (S - fig. 12), but wish to maintain the same diameter saw blade, then use a blade with less teeth. If instead you want to cut workpieces with a reduced thickness, but also maintain the same diameter saw blade, then use a blade with more teeth.

### ALLINEAMENTO DI UNA LAMA SU SEGA CIRCOLARE A BANCO

- Se la lama e la sega non sono allineate in modo corretto al banco e alla guida, si può incorrere in situazioni pericolose (ad es. contraccolpi) e possono insorgere problemi quali bruciature e scheggiature. Per prima cosa leggere il manuale d'istruzioni della macchina: questo è necessario per acquisire le conoscenze utili alla comprensione delle correzioni suggerite in queste pagine.

- Prima di eseguire le seguenti istruzioni, assicurarsi che l'interruttore di accensione sia spento e che non passi corrente.

#### Montaggio della lama:

Si consiglia l'utilizzo di uno strumento di misura e di squadretta goniometrica. Pulire bene la lama prima di montarla sulla macchina. Montare la lama sull'albero e portarla all'altezza massima. Con lo strumento di misura più preciso a propria disposizione, verificare il parallelismo della lama alla scanalatura di scorrimento (Fig. 7) e, se necessario, regolare. Questa fase serve ad ottenere la massima qualità nei tagli trasverso vena e per preparare la guida al taglio lungo vena.

#### Posizionamento della guida per il taglio lungo vena:

dopo aver posizionato la lama in modo che sia parallela alle scanalature di scorrimento, si procede con la regolazione della guida. Essa, idealmente, dovrebbe essere perfettamente parallela alla lama. Ma, data l'impossibilità di posizionare la guida in modo "esatto", è necessario lasciare un leggero margine di tolleranza sul lato di uscita del taglio, in modo che il legno non si incunei tra la guida e la lama. Regolare la guida in modo che, una volta allineata alle scanalature di scorrimento, ci sia uno spazio di 0,1 mm (Fig. 8 - per la regolazione corretta consultare il manuale della macchina).

- Il numero massimo di giri di una lama circolare varia in base al diametro della stessa (Tab. 1). Non superare mai questo valore. Oltre tale limite, la lama perde le sue caratteristiche a scapito della qualità del taglio e della durata dell'utensile e diventa pericolosa per l'operatore.
- La sporgenza della lama (T) rispetto al pezzo lavorato dev'essere almeno uguale all'altezza del dente della lama stessa (Fig. 9). Aumentare od eventualmente diminuire la sporgenza per migliorare la qualità della finitura.
- Il numero di denti in presa (denti che tagliano il legno simultaneamente - Fig. 10) dev'essere 3 o 4. Con meno di 3 denti in presa la lama comincia a vibrare, provocando un taglio non uniforme. A parità di diametro, diminuire il numero di denti all'aumentare dello spessore (S) del materiale da lavorare (Fig. 12). Diminuendo lo spessore del pezzo da lavorare, aumentare il numero di denti.

# Tips for the correct use of a saw blade

## Consigli per l'uso corretto di una lama

11

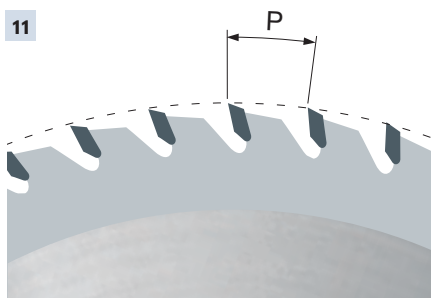

- To obtain the pitch (**P**) of a blade (the distance between teeth: fig. 11 - (see formula "a") multiply the thickness of the workpiece by 1,4142 and divide by 3 (if you want 3 teeth cutting) or by 4 (if you want 4 teeth cutting).
- Formula "b": to obtain the number of teeth (**Z**) of the saw blade, multiply the diameter (**D**) of the saw blade by 3,14 ( $\pi$ ) and divide by the pitch of the saw blade - obtained from the previous formula. The shorter formula "c" allows you to obtain the nr. of the saw blade's teeth, knowing its diameter and the thickness of the workpiece.

- Il passo (**P**) è la distanza tra i denti (Fig. 11). Per ottenerlo (vedi formula "a"), moltiplicare lo spessore del pezzo da lavorare per 1,4142 e dividere per 3 (se si vogliono 3 denti in presa) o per 4 (se si vogliono 4 denti in presa).
- Formula "b": per ottenere il numero di denti (**Z**) della lama, moltiplicare il suo diametro (**D**) per 3,14 ( $\pi$ ) e dividere per il passo (**P**), ottenuto nella formula precedente. La formula "c", più breve, consente di ottenere il numero di denti della lama conoscendo il suo diametro e lo spessore del pezzo da tagliare.

12

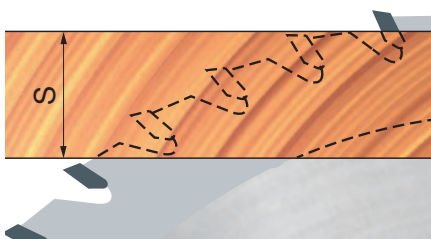

Formula A	Formula B	Formula C
$P = \frac{S \times 1,4142}{3}$	$Z = \frac{D \times 3,14}{P}$	$Z = \frac{D \times 8}{S}$

### KEY:

#### LEGENDA:

**P**= pitch / passo

**S**= thickness of the workpiece / spessore del materiale da lavorare

**Z**= nr. teeth of the saw blade / n. di denti della lama

**D**= diameter of the saw blade / diametro della lama

### ATTENTION:

These formulas are valid for crosscutting and cutting other wood composites of (MDF, plywood, chipboard and laminated panels) and cannot be applied for ripping.

### ATTENZIONE:

Le formule sono valide solo per il taglio trasverso vena e di composti del legno (MDF, multistrato, truciolare e pannelli laminati) e non possono essere applicate per il taglio lungo vena.

# Tips for the correct use of a saw blade

## Consigli per l'uso corretto di una lama

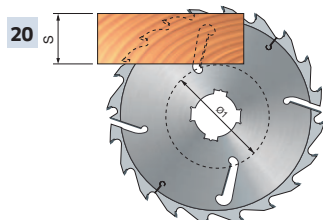
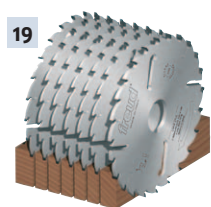
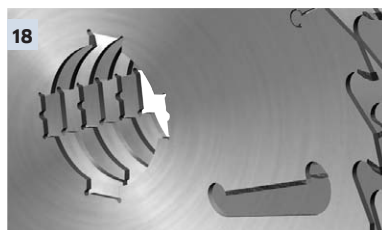
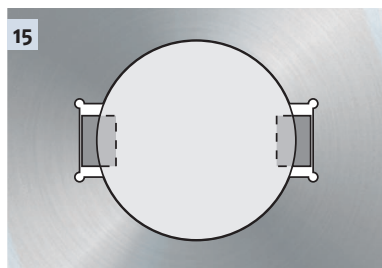
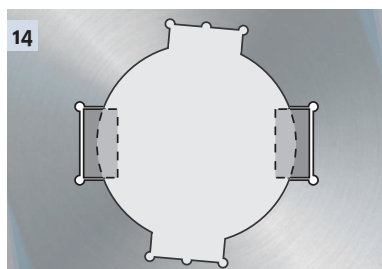
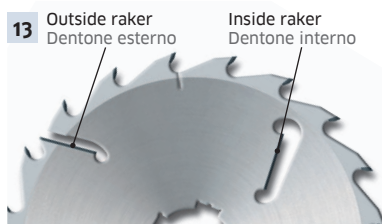

- Rakers (Fig. 13) are inserts in HW that are brazed onto saw blades exclusively for cutting wood. They help keep a distance between the saw blade body and the workpiece, in order to avoid friction and overheating which cause the blade to deform.
- On saw blades for multiripping machines the anti kick-back device is advised in cases where wood has loose knots and discards cases insert themselves underneath the saw blade.
- The pairing of blade and arbor with keyways is excellent in all cases where the keyways are the same (Fig. 14) or smaller than the blade slots (Fig. 15).
- On machines with an arbor with 1 keyway, you can only mount blades with 1 keyway slot (Fig. 16); on machines with an arbor with 2 keyways, you can only mount blades with 2 or 4 keyway slots (Fig. 17).
- You cannot mount a saw blade with 2 keyways on an arbor with 1 keyway slot, because the pairing will not be balanced.
- In case multiripping saw blades are used, it is recommendable to assembly them with alternate keyways (Fig. 18).
- Shoulder blade ensures correct distribution of lateral forces created by crooked planks in heavy duty use. The shoulder blade must be the first blade on the guide side of the multiripping machine.
- Always use shoulder blade with the set of multiripping blades (Fig. 19).
- On multiripping saw blades, the thickness of the workpiece (S) varies according to the diameter of the blade (Ø) and the minimum diameter (Ø1) of the rakers (the rakers position may vary from blade to blade - Fig. 20).

- I dentoni raschiatori (Fig. 13) sono inserti in HW che vengono brasati sul corpo di lame esclusivamente per il taglio del legno. Essi servono a mantenere staccato il legno dal corpo dell'utensile, onde evitare attriti e surriscaldamento che provocano la deformazione della lama.
- Sulle lame per multilame è particolarmente consigliato il limitatore di truciolo nei casi in cui il legno abbia nodi cascanti e se si prevedono sfridi che potrebbero inserirsi sotto la lama, comunque con avanzamenti non troppo elevati.
- L'accoppiamento di lama e albero con chiavette è ottimale in tutti i casi in cui queste hanno le stesse dimensioni delle asole ricavate sulla lama (Fig. 14) o sono leggermente inferiori ad esse (Fig. 15).
- Su macchine con albero con una chiavetta si possono montare solamente lame con un'asola (Fig. 16) e su macchine con albero con due chiavette si possono montare solamente lame con due o a quattro asole (Fig. 17).
- Non si possono montare lame con due asole su alberi con una chiavetta, perché l'accoppiamento risulterebbe non equilibrato.
- Nel caso di lavorazione con multilame in pacco si consiglia di montare con le chiavette alternate (Fig. 18).
- La lama da spalla assicura la corretta distribuzione delle forze laterali prodotte da tavolame distorto, durante lavori gravosi e dev'essere la prima lama sul lato guida della macchina per multilame.
- Usare sempre la lama da spalla con il set di lame per multilame (Fig. 19).
- Sulle lame per multilame lo spessore del pezzo lavorato (S) varia a seconda del diametro della lama (Ø) e del diametro minimo (Ø1) dei dentoni (la posizione dei dentoni raschiatori può variare da lama a lama - Fig. 20).

# Table 1 Tavola 1

Saw blade's technical table to obtain the correct saw blade diameter based on its tip speed and the material to cut  
Tavola per il calcolo ottimale del diametro della lama in funzione della sua velocità periferica e del materiale da lavorare

Tip speed (m/s) Velocità periferica in m/s	Recommended for Consigliata per
50 - 90	Softwood / Legno tenero
50 - 80	Hardwood / Legno duro
50 - 85	Exotic wood / Legno esotico
60 - 80	Chipboard / Truciolare
60 - 80	Joinery wood / Listellare
30 - 60	MDF / MDF
40 - 60	Laminated and bilaminated / Laminato e bilaminato

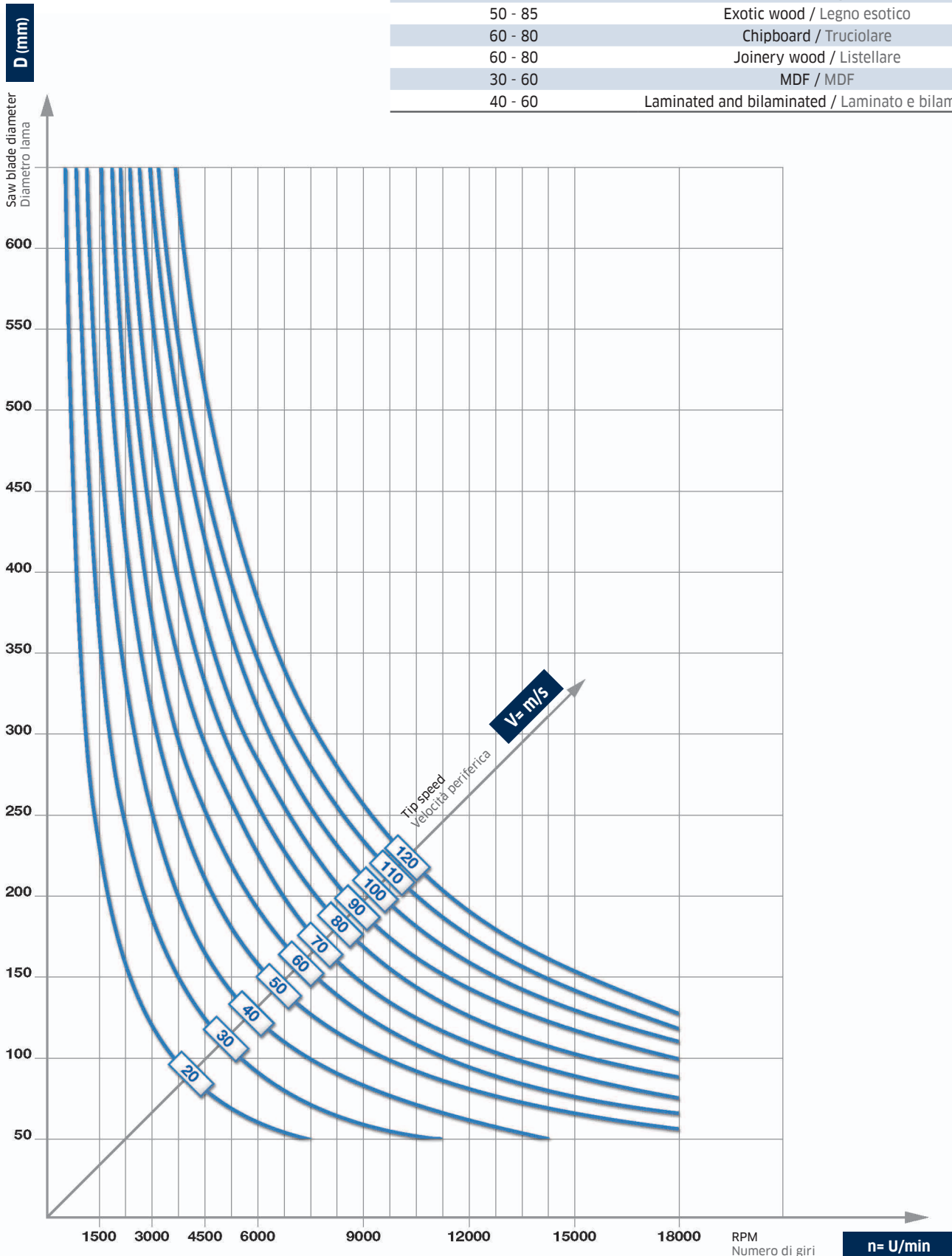

# Table 2 Tavola 2

Saw blade's technical table to obtain the correct tooth feed rate, the feed rate of the material, the number of teeth and the RPM  
Tavola per il calcolo ottimale dell'avanzamento per dente, dell'avanzamento del pezzo, del numero di denti e del numero di giri per le lame circolari

Recommended tooth feed rate (Sz= mm/tooth) Valori ottimali avanzamento dente (Sz= mm/dente)	Recommended for Consigliata per
0,20 - 0,30	Softwood with grain / Legno ten. lungo vena
0,10 - 0,20	Softwood cross grain / Legno ten. trav. vena
0,06 - 0,15	Hardwood / Legno duro
0,10 - 0,25	Chipboard / Truciolare

Recommended tooth feed rate (Sz= mm/tooth) Valori ottimali avanzamento dente (Sz= mm/dente)	Recommended for Consigliata per
0,05 - 0,12	Plywood / Multistrati
0,05 - 0,10	Laminated board / Impiallacciato
0,02 - 0,05	Aluminum and plastic laminated chipboard Alluminio e truciolari con rivest. plastico

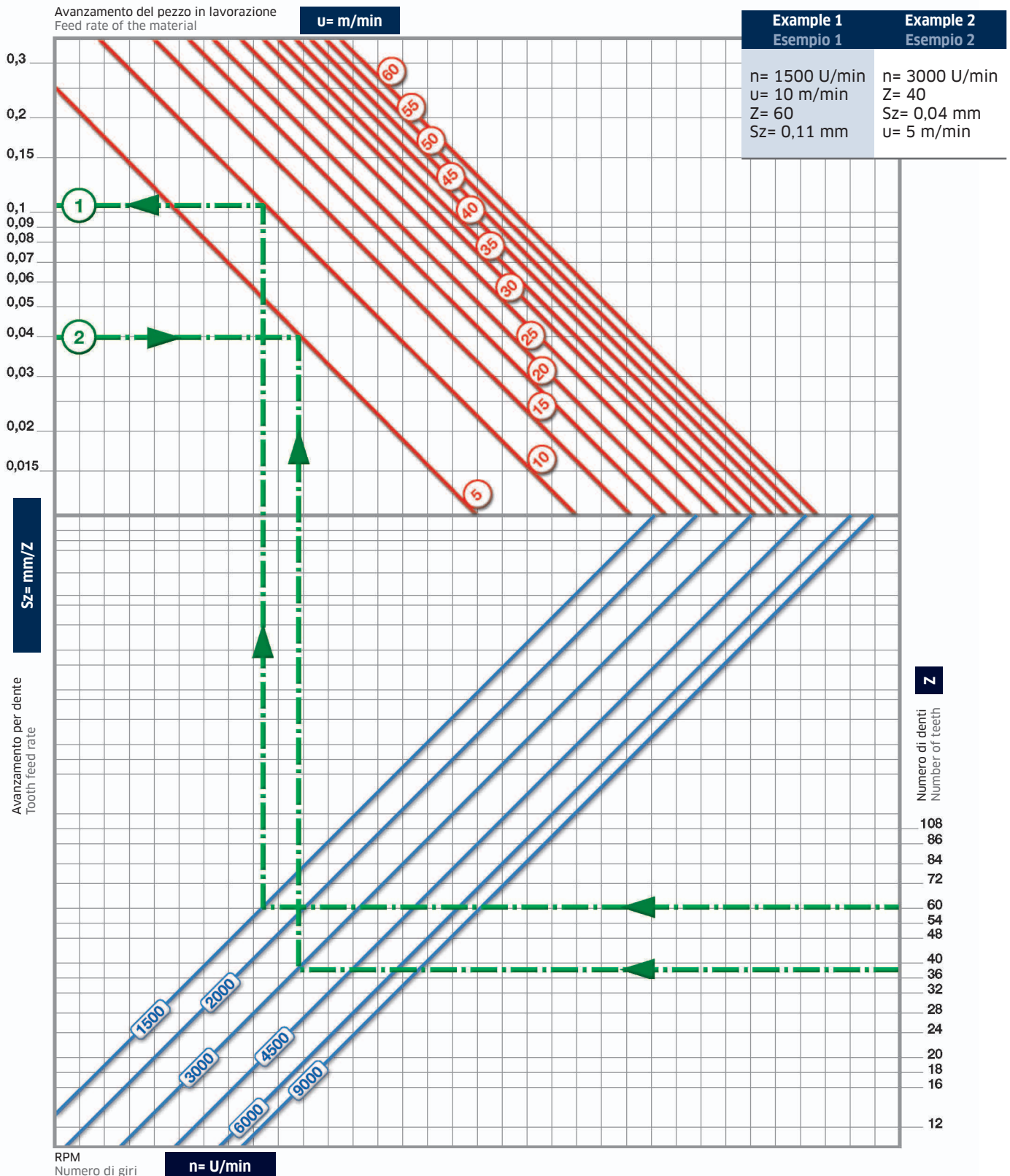

# Legenda dei simboli e delle abbreviazioni

## Explanation of symbols and abbreviations

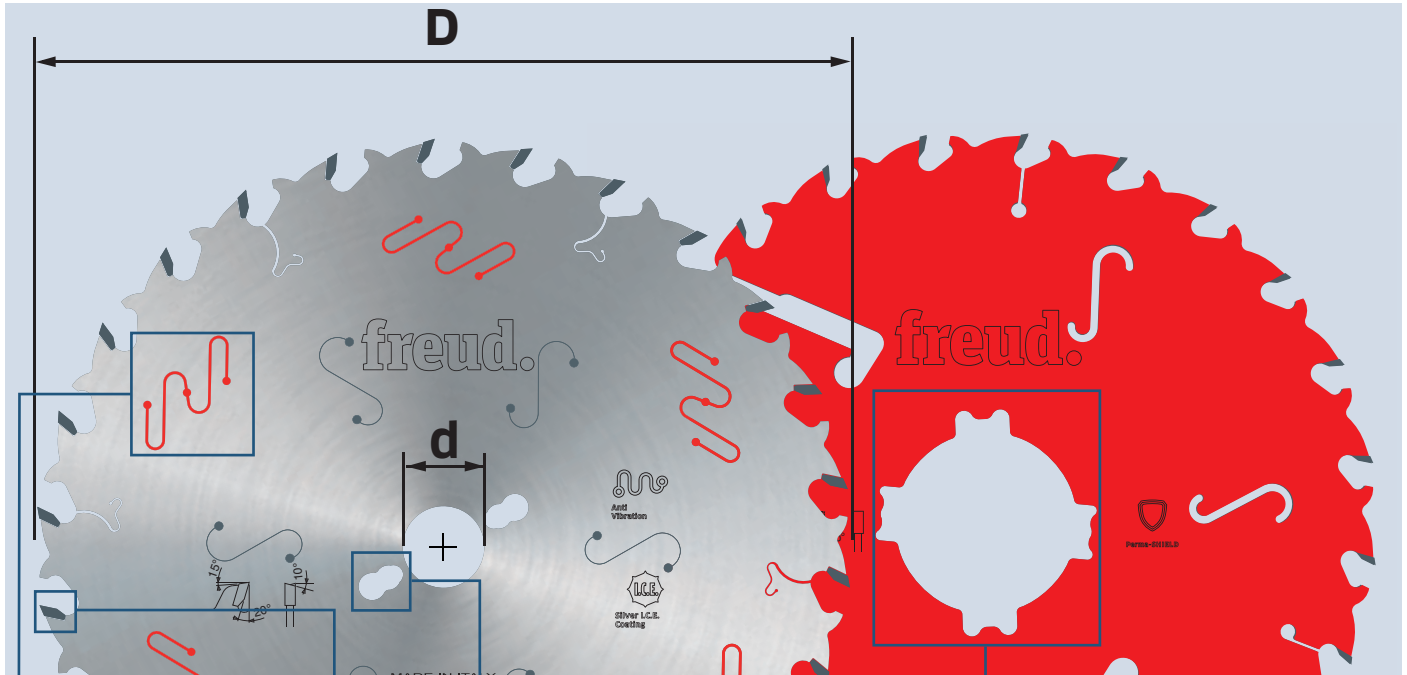

	D	B	b	d	Z	NL FT	KN CH	Code Codice	SAP SAP
	250	3,2	2,2	30	22		FT01	<b>ABCD 1234</b>	A00BC01234
	250	3,2	2,2	70	22		4CH 21x5	<b>ABCD 1234</b>	A00BC01234
	300	3,2	2,2	30	26		FT01	<b>ABCD 1234</b>	A00BC01234

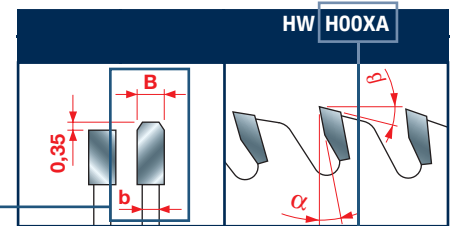

Tooth features - Caratteristiche del dente

MICRO-GRAIN CARBIDE (HW) HARDNESS USED FOR MANUFACTURING TIPS  
GRADI DI DUREZZA DEL METALLO DURO (HW) UTILIZZATO PER LA PRODUZIONE DEI TAGLIANTI

< INCREASING IMPACT STRENGTH • MAGGIORE ELASTICITÀ      INCREASING HARDNESS • MAGGIORE DUREZZA >

K10S	H01K	H00K	H00XA	H00XF
Vickers hardness • Durezza (HV10)	Transverse rupture • Tenacità (KlC)	Density • Densità (gr/cm³)		

# Legenda dei simboli e delle abbreviazioni

## Explanation of symbols and abbreviations

PERFORMANCE		
Ultimate Eccellente	High Ottimo	Standard Buono
●		

CHART ABOUT THE SAW BLADE'S PERFORMANCE  
TABELLA CON IL LIVELLO DI PERFORMANCE DELLA LAMA

### SYMBOLS TO READ THE PRODUCT TABLES

#### SPIEGAZIONE DEI SIMBOLI PER LA LETTURA DELLE TABELLE PRODOTTO

<b>D</b>	Diameter Diametro	<b>d</b>	Central bore Foro centrale	<b>α</b>	Hook angle Angolo mordente
<b>B</b>	Cutting thickness Spessore di taglio	<b>Z</b>	Number of teeth Numero di denti	<b>β</b>	Back relief angle Angolo di spoglia dorso
<b>B-B1</b>	Adjustable cutting thickness Spessore di taglio regolabile	<b>KN CH</b>	Keyways Chiavette	<b>Code Codice</b>	Item code Codice articolo
<b>b</b>	Saw blade body thickness Spessore corpo lama	<b>NL FT</b>	Pin holes Fori di trascinamento	<b>SAP SAP</b>	Item code - for SAP users only Codice articolo - solo per utenti SAP

### OTHER SYMBOLS

#### ALTRI SIMBOLI

	Silver I.C.E. Coating Trattamento Silver I.C.E. Coating		Multi-rip saw blade for ripping of softwood Lame per multilame, per legno tenero		Saw blade to cut solid wood and composites with nails and impurities Lame per legni e compositi con chiodi o impurità
	Perma-SHIELD coating Trattamento Perma-SHIELD		Multi-rip saw blade for ripping of hardwood Lame per multilame, per legno duro		Saw blade to cut laminates Lame per laminati
	Antivibration technology Tecnologia Antivibration		Saw blade for ripping of softwood Lame per legno tenero lungo vena		Saw blade to cut veneered Lame per impiallacciati
	Saw blade for miter saws Lama per macchine troncatrici		Saw blade for ripping of hardwood Lame per legno duro lungo vena		Scoring saw blade for laminates Lama incisore per laminati
	Saw blade for portable machines Lama per macchine portatili		Saw blade for ripping of softwood Lame per legno tenero lungo vena		Saw blade to cut picture frames Lame per cornici
	Right hand or left hand Rotazione destra o sinistra		Saw blade for ripping of hardwood Lame per legno duro lungo vena		Saw blade to cut plastic materials Lame per materiali plastici
	Tools for automatic feed Utensili per avanzamento meccanico		Saw blade for cross cutting of softwood Lame per legno tenero trasverso vena		Saw blade to cut plexiglas Lame per plexiglas
	Disposable knives Coltelli a gettare		Saw blade for cross cutting of hardwood Lame per legno duro trasverso vena		Saw blade to cut solid surfaces Lame per materiali polimerici
			Saw blade for ripping and cross cutting of softwood Lame per legno tenero lungo e trasverso vena		Saw blade to cut non-ferrous metals Lame per metalli non ferrosi
			Saw blade for ripping and cross cutting of hardwood Lame per legno duro lungo e trasverso vena		Saw blade to cut ferrous metals Lame per metalli ferrosi
			Saw blade to cut wood composites Lame per composti di legno		

**freud.**

---

**freud S.p.A.**  
**Società Unipersonale**  
Via Padova, 3  
33010 Tavagnacco (UD) IT  
Tel. +39 0432 551411  
Fax +39 0432 551440  
info@freud.it  
www.freud.it